

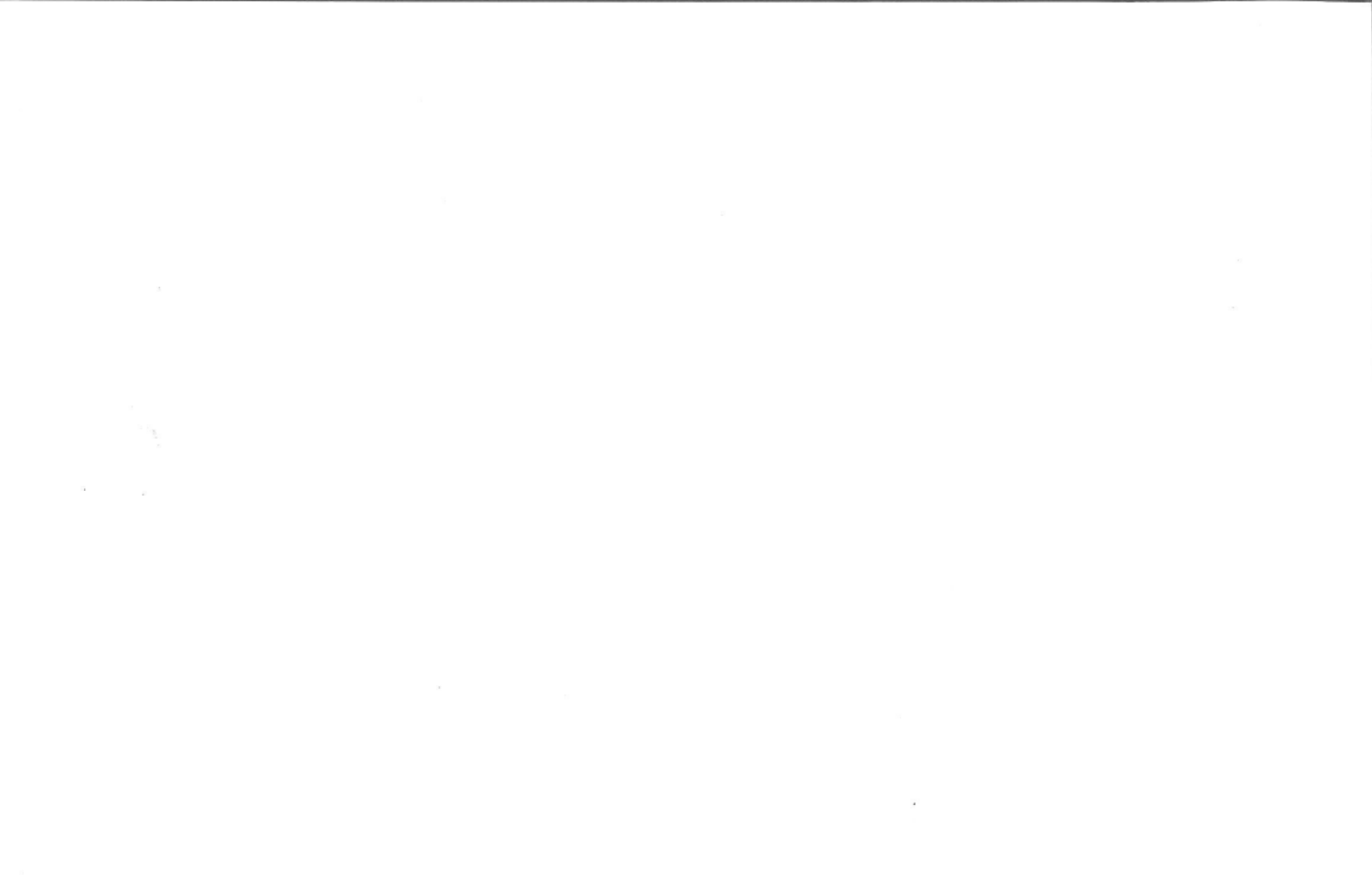

Harley-
Davidson's



PREMIUM SOUND SYSTEM





Harley-Davidson, Inc.

Dear Harley-Davidson Owner:

This owners manual was prepared to acquaint you with the many features and controls of your new Harley-Davidson sound system and CB/Intercom system. These systems offer a new degree of sophistication to the Harley-Davidson owner. A totally integrated concept was used for its design, allowing many unique features to be included. For this reason, we recommend you read this manual thoroughly to understand its function and operation.

WARNING

Do not change tapes while riding or allow the sound system to break the concentration needed for safe riding. Loss of concentration or a sound level so high that you cannot hear vehicle horns or sirens could result in loss of control and personal injury.

HARLEY-DAVIDSON STEREO RECEIVER FEATURES

The Harley-Davidson stereo receiver is a 3 band (AM, FM Stereo, Weather Band) unit with full function cassette tape drive. Receiver frequency ranges are:

AM: 530 - 1700 kHz, 10 kHz steps

FM: 88.1 - 107.9 MHz, 200 kHz steps

WB: 162.400 - 162.550 MHz, 25 kHz steps

Principle features include:

- Electronic softload and softject cassette deck featuring auto reverse, pushbutton eject, pinch roller release upon power off, ignition off or tape off.
- Remote controls for tuning, band change/tape select, volume control, time/frequency recall.
- Electronic digital volume control.
- Automatic Volume Control (AVC) - automatically adjusts volume to compensate for ambient noise due to motorcycle speed.
- Time of day clock with selectable clock/frequency display dominance plus separate recall button.
- Programmed reminder to clean tape heads. "CLEAN" is displayed accompanied by a beeper each 15 hours of tape play.

- Weather band frequencies are displayed as NOAA channel numbers.
- 40 watts of total output; 20 watts per channel.
- Dynamic Noise Reduction (DNR™) circuitry significantly reduces noise level heard in radio or tape player.

RECEIVER OPERATION

To turn the receiver on, press the PWR button (12) at the right side of the front panel. The volume can be adjusted with the volume control lever (A) on the left handlebar.

RADIO STATION TUNING

The receiver has three tuning modes: Manual, Seek and Scan. The desired mode is selected with the SE-SC button (9) on the front panel. "SE" appears in the LCD (17) when seek mode is selected. "SC" is displayed when scan is selected. When neither seek nor scan is selected, manual tuning is automatically selected.

MANUAL TUNING — Selects manual tuning mode. Quickly pushing the tuning lever (B) (on the right handlebar) UP will cause the frequency to increment one step. Holding the lever UP will cause the frequency to continue to increment. Similar operation occurs for DN movements of the tuning lever. Tuning is continuous around the ends of the frequency scale.

FRONT PANEL CONTROLS

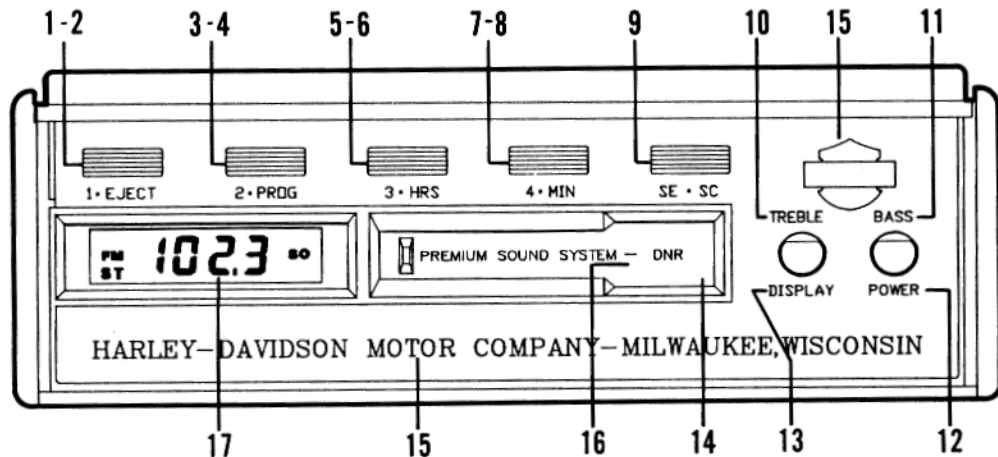

- 1. Station Pre-Set 1 / Memory Set
- 2. Tape Eject Switch
- 3. Station Pre-Set 2 / Memory Set
- 4. Program Control
- 5. Station Pre-Set 3 / Memory Set
- 6. Hour Set Switch

- 7. Station Pre-Set 4 / Memory Set
- 8. Minute Set Switch
- 9. Manual, Seek, Scan, Tuning Control
- 10. Treble Rotary Control
- 11. Bass Rotary Control
- 12. Power Switch (Push)

- 13. Display Switch
- 14. Tape Door
- 15. Harley-Davidson Shield and Graphic. Backlit for Night
- 16. DNR (Dynamic Noise Reduction) Graphic
- 17. LCD Custom Display

HANDLEBAR CONTROLS — LEFT

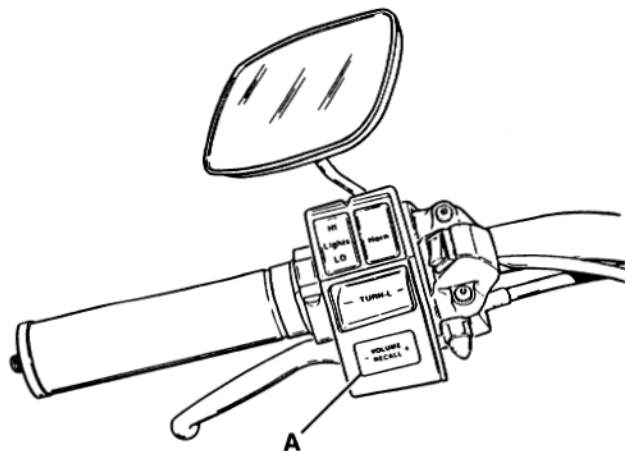

A — VOLUME CONTROL / RECALL LEVER
(Left and right movement for VOLUME CONTROL, Press for RECALL)

HANDLEBAR CONTROLS — RIGHT

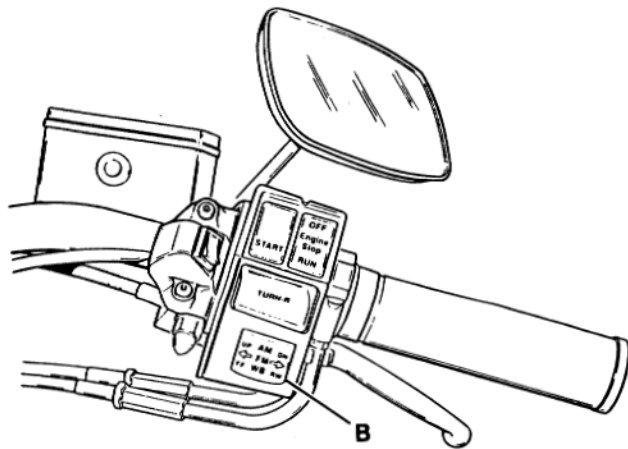

B — TUNING / TAPE FAST FORWARD, REWIND / BAND SELECT LEVER
(Left and right movement for TUNING, TAPE FAST FORWARD and REWIND, Press for BAND select)

FM BAND,
STEREO STATION,
SEEK MODE

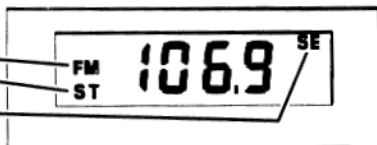

AM BAND,
MANUAL MODE

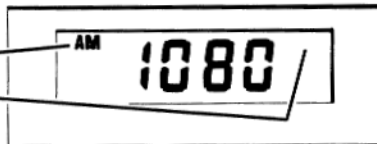

FM BAND,
STEREO STATION,
CLOCK DISPLAY
SCAN MODE

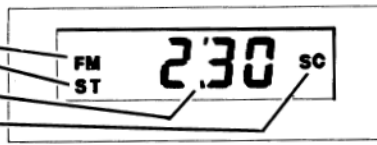

WEATHER BAND,
NOAA* CHANNEL 4

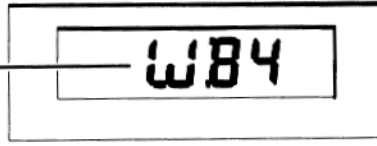

RADIO OFF
CLOCK DISPLAY

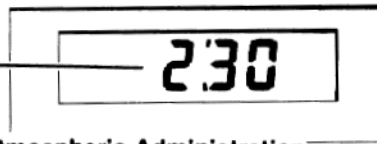

* National Oceanic Atmospheric Administration

TAPE MODE,
SEEK MODE,
SIDE 1 SELECTED

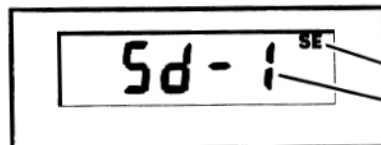

TAPE MODE,
SCAN MODE,
SIDE 2 SELECTED

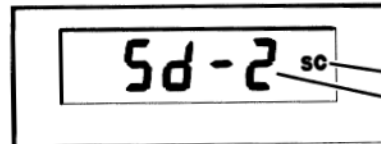

TAPE MODE,
SEEK MODE,
FAST FORWARD
ACTIVE

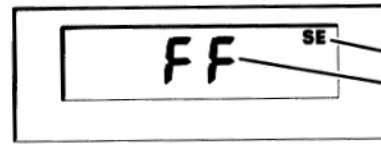

TAPE MODE,
MANUAL MODE,
REVERSE WIND
ACTIVE

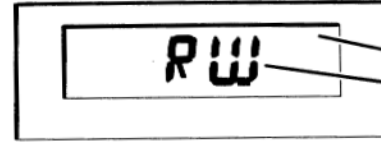

15 HOUR TAPE
HEAD CLEAN
REMINDER

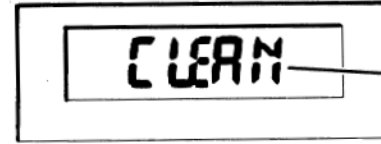

SEEK TUNING — The seek tuning mode allows the receiver to tune up or down the frequency scale to the next strong station. Set "SE" in the LCD using the SE-SC button (9). A subsequent UP movement of the tuning lever (B) causes the next strong station upward on the frequency scale to be tuned. Similar operation occurs for DN movements of the tuning lever (B). Repeat use of UP or DN function until desired station is found.

SCAN TUNING — Scan tuning allows the receiver to continuously tune up or down the frequency scale to the next strong station. Each station remains tuned for approximately ten seconds. Then, another strong station is found, etc., indefinitely until SCAN is cancelled. Select scan mode with the SE-SC button (9). A subsequent UP or DN movement of the tuning lever initiates the active scan operation. The active scan may be cancelled by a second push of UP or DN, **respectively**, on the tuning lever.

PRESET MEMORY — A station frequency may be stored with any of preset buttons (1, 3, 5 and 7). Holding the preset button down longer than approximately 1.5 seconds causes the currently tuned frequency to be stored into that preset location. A beep occurs when the store operation is complete. Any subsequent **quick** push of that preset will tune the stored frequency.

PRESET TUNING — Quickly pressing any of the four preset buttons (1, 3, 5 and 7) tunes a stored frequency for the band currently selected.

TAPE OPERATION

AUTO LOAD — Insert a cassette into the tape slot until it is flush with the front of the receiver. The unit will automatically pull the cassette into the player and load it into playing position. The currently selected side (program) will be displayed in the LCD.

PROGRAM CHANGE CONTROL — When the tape reaches the end, the unit will automatically change tape side (program) and reverse direction. The side may be changed manually by pushing the PROG button (4) on the front panel. The newly selected side will be displayed in the LCD as “Sd-1” or “Sd-2”.

TAPE FAST WIND OPERATIONS — The tape may be fast advanced or rewound in three modes: manual, seek or scan.

MANUAL — Manual mode is selected with the SE-SC button (9). Manual mode is set when neither “SE” or “SC” appears in the LCD. A subsequent UP movement of the tuning lever (B) causes the tape to fast forward and latch in this mode. “FF” is displayed in the LCD. The fast wind is cancelled by a second UP push of the tuning lever. Similar operation occurs when DN is pushed on the tuning lever, with “RW” being displayed while the tape rewinds.

TAPE SEEK — Tape seek mode is selected with the SE-SC button (9). The “SE” annunciator appears in the LCD when seek mode is selected. A subsequent UP movement of the tuning lever (B) causes the tape to fast forward to the next selection, then resume play. See NOTE below. While the tape is fast forwarding, “FF” is displayed in the LCD. A second push of UP will stop the tape fast wind at any time. Similar operations occur if a DN movement of the tuning lever occurs. In this case, the tape rewinds to the beginning of the previous selection and resumes play. “RW” appears in the LCD while the tape is rewinding.

NOTE

Some home recorded tapes will not operate properly in the SEEK or SCAN operation. This can happen if there is too much “NOISE” between songs. If a tape has too much noise between songs, it will continue to “FF” or “RW” until it finds a quiet spot on the tape. To insure home recorded tapes operate properly, record a three second “gap” (by raising phonograph needle or other means) between songs.

TAPE SCAN — Tape scan mode is selected with the SE-SC button (9). The “SC” annunciator appears in the LCD when scan mode is selected. A subsequent UP movement of the tuning lever initiates active scan. The tape will fast forward to the next selection, then resume play. See NOTE above. The selection is played for approximately ten seconds then another fast forward begins and continues until the next selection is found. This continues indefinitely through autoreverses until active scan is cancelled. Active scan is cancelled by a second UP push of the tuning lever. Similar operation occurs for DN movement of the tuning lever. In this case, the tape rewinds to the previous selections and “RW” is displayed in the LCD during rewind operations.

EJECT — The cassette can only be ejected when the tape is playing by pressing the EJECT button (2).

RECOMMENDATIONS FOR TAPE OPERATION

- Avoid using 90 minute (C-90) or 120 minute (C-120) tapes because they are prone to jam due to their extreme thinness.
- If cassette is stored in deck, it should be in the loaded position. This restrains the cassette spools from unwinding the tape due to vibration.
- Avoid low quality cassettes which have high levels of friction in internal parts.
- Keep cover closed at all times.
- Store cassettes in cool, dry place away from direct sunlight.
- Clean heads at 15 hour intervals or every month.

CONTROLS — FRONT PANEL

POWER/BASS — (Dual function knob (11 and 12)). Turning knob adjusts audio bass response (clockwise increases bass). Pushing knob turns radio off or on.

DISPLAY/TREBLE — (Dual function knob (10 and 13)) Clockwise turn of knob increases treble. Pushing knob sets opposite frequency/clock dominance of currently selected mode. If frequency is set, frequency is displayed in LCD, except upon actuation of RECALL button (A) (see RECALL button description). If clock dominance is set, time of day is displayed, except during tuning operations or actuation of RECALL button.

SE, SC — (Radio tuning mode/tape advance mode button (9)). In radio mode, this button selects manual, seek or scan mode. The current tuning mode is displayed in the far right portion of the LCD display. Seek is displayed as "SE", scan as "SC". Manual mode is denoted by the absence of both "SE" and "SC".

PRESET — (1, 3, 5 and 7) (Preset recall/preset memory load buttons (1, 3, 5 and 7)). These 4 buttons store or recall preset frequencies.

EJECT — (Eject button (2)). Pushing EJECT button ejects cassettes **only if currently in tape mode**.

PROG — (Program select button (4) in tape mode). Pushing PROG button selects opposite cassette side for play. Current selected side is displayed in LCD as "Sd-1" or "Sd-2". When end of tape is reached, an autoreverse is executed which changes the tape automatically to the other side.

HRS — (Time of day hours set button (6)). Pushing button quickly increments HRS in Time of Day by 1 hr. Holding HRS button causes HRS to continuously increment until released. This button is active only when radio is **off**.

MIN — (Time of Day minutes set button (8)). Pushing button quickly increments minutes in time of day by 1 minute. Holding MIN button causes minutes to continuously increment until button is released. This button is active only when radio is **off**. Actuating minutes button sets seconds to zero.

CONTROLS — REMOTE

VOLUME UP/DN — (Volume control lever (A)). Moving lever switch to rear position lowers volume; moving lever switch forward raises volume. Volume is raised (or lowered) as long as switch is held, and until minimum or maximum volume is reached.

RECALL — (Frequency/time recall lever (A)). Recalls frequency or time of day into LCD display: If frequency mode is currently dominant, pushing RECALL displays the time of day in the LCD for 10 seconds; then, the frequency display resumes. If clock mode is dominant, pushing RECALL displays the frequency (or tape side) in the LCD for 10 seconds; then, the time of day display resumes.

UP/FF, DN/RW — (Radio tuning and tape fast wind lever (B)). Initiates up or down tuning operation in radio mode. In tape mode, initiates Fast Forward or Rewind tape movement. Function initiated depends upon current SE - SC status. (See SE-SC functions). A 2nd push of UP/FF or DN/RW cancels fast tape movement or radio SE, SC tuning operation.

BAND/TAPE SELECT — (Tuning or band select lever (B)). When the radio is initially connected to its power source, it will select FM band the first time it is turned on. If no cassette is subsequently loaded, pressing the BAND lever will cause the band to cycle through the sequence WB, AM, FM, etc. The band changes once each push of the lever. The currently selected band is displayed on the LCD display. Any time the radio is on and a cassette is inserted in to the tape mechanism, tape mode is activated. If a cassette is loaded, the band sequence will be AM, FM, WB, TAPE as the BAND lever is repeatedly pushed. When pressing the BAND lever with the Weather Band selected you will experience a delay and hear the TAPE drive start. Pressing the BAND lever again will result in a delay as the TAPE drive stops. Once the TAPE drive has stopped, the radio will return to the AM band. The cassette does not eject when leaving tape mode in this manner, but remains ready to be selected again. The cassette may be ejected with the EJECT button on the radio panel. The cassette may be ejected **only** when the BAND lever is currently selecting tape mode. Upon eject, the band and frequency active when the cassette was inserted will be recalled. This is true even if the BAND lever has selected other bands after the cassette was loaded. If the ignition key is turned off, a loaded cassette remains loaded (the pinch rollers release) and is ready for play when the ignition is turned on again. The same is true for the radio PWR switch. The radio always returns to the last selected band, frequency or tape mode when ignition and power is turned on again.

DYNAMIC NOISE REDUCTION (DNR™)

DNR system, as the name implies, significantly reduces the level of noise normally heard in a radio or tape player. Unlike many other noise reduction systems, DNR does not require special processing of the music source prior to playback. Therefore, DNR is effective with radio, and all recorded tapes. DNR will further decrease the noise level when used with other noise reduction systems.

The DNR Dynamic Noise Reduction system is authorized for use by National Semiconductor. DNR is a trademark of National Semiconductor.

AVC OPERATION

The automatic volume control (AVC) adjusts volume level to compensate for ambient noise associated with motorcycle speed. This function is normally in operation, and requires no operator action.

FUSE REPLACEMENT

In the unlikely event that it becomes necessary to replace either of the two in-line fuses, your Harley-Davidson dealer should be consulted. The two special fuses are in the feed line harness at the rear of the radio. It is essential that replacement fuses are of the correct value.

AM vs FM RECEPTION

There are two basic types of commercial radio broadcasting: AM, which stands for Amplitude Modulation, and FM, which stands for Frequency Modulation. AM radio has advantages which include large signal reception ranges (up to 100 miles or more), fairly constant signal reception, which in a moving motorcycle is important, and a large selection of stations to choose from. One of the most noticeable disadvantages of AM radio is its susceptibility to power line and electrical storm interference. This is heard as loud popping and crackling noises.

There are many advantages to FM radio, such as high fidelity sound, the ability for stereo signals to be broadcast, an increasingly wide range of broadcasting formats, and a signal which is virtually free of unwanted interference. Because FM radio waves reflect, FM reception is often possible under bridges and in tunnels where AM reception is impossible. However, because of this same characteristic, FM radio waves are easily blocked by tall buildings or large hills. The greatest disadvantage of FM radio is its broadcast range. The usual range of an FM station is 25 miles or less. This is caused by the fact that FM radio waves travel through space in straight lines, often referred to as "Line of

Sight". The earth's ionosphere is penetrated by FM signals. Thus, FM signals cannot be received beyond the horizon. The ionosphere reflects AM radio waves which is the reason for AM's long range. FM radio receivers require a certain minimum level of signal strength to provide noise free reception. As the distance between your motorcycle and the station to which you are tuned increases, the FM signal will become weaker, performance will decrease and interference will become increasingly noticeable. When the signal being received drops below the minimum level, it is normal for the receiver to pick up electrical interference such as ignition noise from surrounding vehicles, electric signs, power lines, etc., which may interfere with or completely drown out the FM station to which you are tuned.

When riding in the outer limits, or "Fringe" area, of an FM station's broadcast area, the reception may fade out completely or flutter in and out when objects pass between the station's transmitter and your motorcycle. The rate at which the flutter occurs in this case is dependent on your motorcycle speed in passing the objects. This phenomenon is most noticeable when riding through hilly or mountainous terrain.

Your receiver has circuits which minimize, and in many cases, eliminate the flutter due to weak stereo signals. The circuits detect weak stereo signals and automatically blend to the stronger FM Mono mode. The transition is smooth and flutter free because it occurs over a range of signal conditions, rather than a minimum threshold, as in all other FM Mono/Stereo receivers.

SPECIFICATIONS

FM Band

Tuning Range 88.1 - 107.9 MHz

Limiting Sensitivity (3 dB) .. 1.5 μ V Typ.
@ 75 ohms

Quieting Sensitivity (30 dB) . 1.5 μ V Typ.
@ 75 ohms

Spurious Signal Rejection .. 75 dB minimum

Image Rejection 50 dB minimum

IF Rejection 85 dB

AFC PLL Circuit Receiver always on
station frequency

Audio Frequency Response 30 - 15,000 Hz

Bass Boost Custom

Treble Boost 10 dB @ 10kHz

Stereo Separation 35 dB @ 1kHz

High Blend Separation Less than 4 dB
@ 10 μ V

AM Band

Tuning Range 530 - 1700 kHz

20 dB S/N Sensitivity 15 μ V Typ.

Image Rejection 65 dB minimum

If Rejection 60 dB minimum

Bandwidth (- 6 dB) 6 kHz (+ 4, - 2)

Strong Signal Distortion.... 5% (+ 5)
(Input 2V)

S/N Ratio, Large Signal..... 55 dB minimum

Tape

Tape Speed 4.75 cm/s
(+ 3%, - 1%)

WOW and Flutter (JIS) 0.1% (+ .05)

Track Cross-Talk 55 dB minimum

Channel Cross-Talk 40 dB minimum

S/N 55 dB minimum

Frequency Response 50 - 15,500 Hz
(- 3 dB)

Weather Band

Tuning Range162.400 – 162.550 MHz
Limiting Sensitivity (3 dB) .. 1.25 μ V Typ. @ 75 ohms
Quieting Sensitivity (30 dB) . 1.5 μ V Typ. @ 75 ohms
S/N Ratio, Large Signal.....60 dB minimum
IF Rejection80 dB minimum
Spurious Rejection55 dB minimum

Audio Output Power

Output Power (400 Hz) .. 40 watts total
(20 watts per channel \times 2)
12 watts per channel @ less
than 1% distortion (THD)
Total 2 channels, 24 watts @
less than 1% distortion (THD)

One watt distortion (1 KHz at Audio Output)

FM (Input).....less than 0.5% THD

AM (Input)less than 0.5% THD

WB (Input)less than 2.0% THD

Tape (Input)less than 1.5% THD

Amplifier (only)less than 0.3% THD

HARLEY-DAVIDSON CB/INTERCOM/REAR SPEAKERS

The Harley-Davidson CB/Intercom/Rear Speakers system includes a digitally tuned 40 channel CB transceiver, "two-up" intercom, and a 20 watts per channel rear speaker amplifier.

Principle features are:

- Fuel tank console panel that includes:
 - A large two digit CB channel LED display
 - Continuously adjustable CB squelch level
 - LO/DX (Local/Distance) CB sensitivity adjustment
 - Momentary UP/DOWN CB channel tuning
 - Continuously adjustable CB volume including CB ON/OFF
 - Intercom ON/OFF

- Conveniently positioned handlebar mounted "Push to Transmit" switch.

- Fairing-mounted music source switch (AVC disable).

- Rear mounted passenger controls that include:
 - Continuously adjustable rear speaker volume
 - CB "Push to Transmit"
 - Stereo receiver tuning and band switching

- Voice activated mute.
- Enhanced headset fidelity.
- “Quiet Ride” feature.
- Hand-held microphone compatibility.
(For areas that do not allow speakers mounted in helmets.)

WARNING

Some local governments prohibit use of helmet-mounted speakers. Please check with local authorities and obey applicable laws and regulations.

INTERCOM OPERATION

Inter-bike communications and voice activated mute are initiated when the INTERCOM switch (4) is moved forward. Voice activated mute provides interruption (or muting) of Stereo signals when a certain voice level is detected by the microphone circuits. This provides easier intercom operation. To further enhance this feature, there is a delay of approximately two seconds before stereo signals are restored, allowing for pauses in conversation.

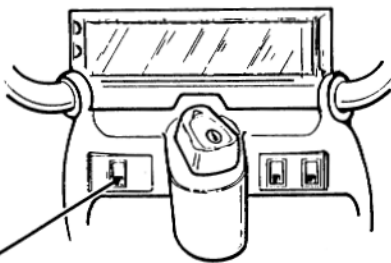
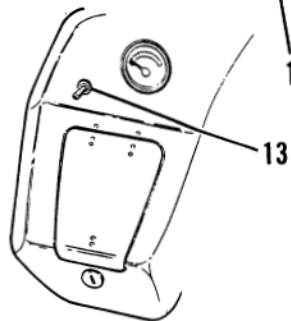
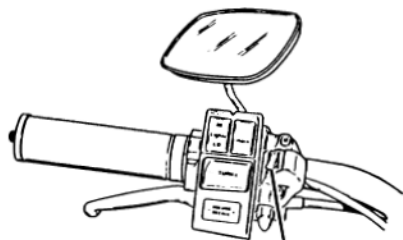

13

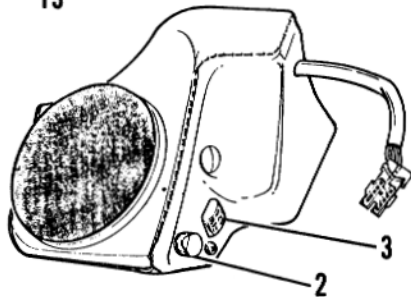

1. Driver P.T.T. Switch
2. Volume/P.T.T.
3. Function Control
4. Intercom On/Off
5. C.B. Volume

6. Channel Display
7. Squelch
8. Local/Distance
9. Channel Selector

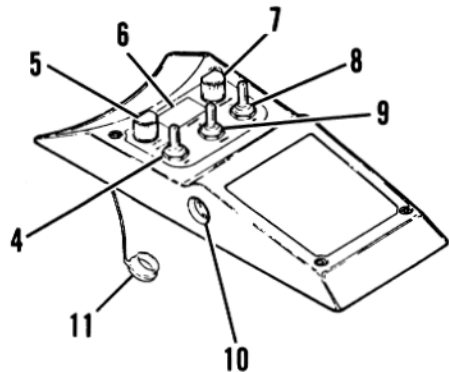

10. Headset Jack Plug
11. DIN Plug
12. Helmet Connector
13. Speakers Switch

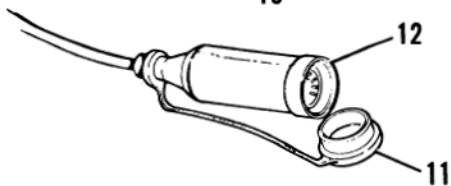

HELMET CONNECTORS

Both the DRIVER HELMET CONNECTOR (10) and the PASSENGER HELMET CONNECTOR (12) will accept an industry standard five pin DIN type helmet system. For areas that do not permit helmet speakers, a special hand-held microphone can be used for CB transmitting. This part is available through Harley-Davidson's Parts and Accessories Division. To prevent water entry, it is very important that any time a headset or hand-held microphone is not in use, that the DIN PLUG (11) be placed in the connector openings.

REAR VOLUME & REAR TUNER CONTROL

The REAR SPEAKER VOLUME CONTROL (2) allows the passenger to adjust the rear speaker volume by rotating the knob. The REAR TUNER switch (3) allows passenger control of Stereo Receiver UP and DOWN tuning, cassette fast forward and rewind, and band selection. (See Stereo Receiver Section for a more detailed description.)

SPEAKER CONTROL

When the SPEAKERS switch (13) is placed in the down position, Stereo Receiver audio and CB audio are directed to the fairing speakers and AVC (Automatic Volume Control) is active. The other position directs these audio signals to the headsets and AVC is deactivated. Stereo signals are present at the rear speakers in either position.

“QUIET RIDE” FEATURE

CB interruptions and wind or road noise picked up by the microphone can become annoying. To get rid of these noises while retaining your music and intercom capabilities, turn off the CB and place the intercom switch in the OFF position. If you wish to re-establish inter-bike communication, each person can do so by depressing their respective PTT switches (1), (2). Both microphones will be active while one or both switches are depressed.

CB OPERATION

To turn the CB on, rotate the CB VOLUME CONTROL (5) clockwise until a click is heard. Further rotation will continuously increase CB volume.

CB CHANNEL TUNING

The CB tuning can be either incremented or decremented. Pushing the UP/DOWN switch (9) forward will increment channel tuning and pushing it backwards will decrement channel tuning. If the UP/DOWN switch is moved and then released, the tuning will change one channel per movement. If the UP/DOWN switch is held in position, the tuning will rapidly slew until released. The currently tuned channel will be visible in the DISPLAY (6).

CB SQUELCH & LO/DX

CB squelch can be adjusted by rotation of the SQUELCH control (7). Clockwise rotation increases the level of received CB signal necessary to allow CB and vice versa. The LO/DX switch (8) reduces the sensitivity of the CB receiver when in LO, thus changing the range of operation of the squelch control and allowing quieter receiver operation.

CB TRANSMISSION

CB transmission is accomplished by depression of either the driver PTT switch (1) or the passenger PTT switch (2). Transmission is over the channel shown in the display. Depression of either of these switches initiates inter-bike communications regardless of whether the CB or Intercom is ON or OFF.

WARNING

If CB is on but at minimum volume and squelch is adjusted such that audio muting is occurring, it will appear that the stereo receiver is not functioning. Your first inclination will be to increase stereo volume, then if squelch is adjusted or the CB is turned off, your stereo volume may be too loud. If your stereo seems to be non-functional, please turn CB off before increasing stereo volume.

NOTICE

This system was designed with conservative amplification factors in the microphone circuits. This is to reduce the feedback risk that is always present when microphones are around, and to minimize road and wind noises. Because of these considerations, you will obtain best performance when the microphone is kept close to your mouth. You may even find it unnecessary to use a wind sock.

CONTROL INTERACTION

THIS ...

WILL PREVENT THIS

Squelch Open	— Fairing Music
	— Headset Music
	— Rear Speaker Music
Squelch Closed	— CB Audio
CB Off or Low Volume	— CB Audio
Front or Rear PTT On	— Fairing Music
	— Headset Music
	— Rear Speaker Music
	— CB Audio
Handlebar Volume Down	— Fairing Music
	— Headset Music
	— Rear Music
Rear Volume Down	— Rear Speaker Music
Speaker Switch-Fairing Position	— Headset Music
Speaker Switch-Headset Position	— Fairing Music
Intercom Switch Off	— Voice Communications
	(Unless either PTT is depressed)

LIMITED 12-MONTH WARRANTY

Harley-Davidson, Inc., warrants to the original purchaser and his authorized transferees, that this Harley-Davidson radio will be free from factory defects in material and workmanship, under normal use and service, for a period of twelve (12) months from date of purchase. This warranty does not cover defects or damage due to abuse, misuse or improper installation.

To obtain service during the warranty period, you must present the vehicle, with radio intact, to any authorized Harley-Davidson dealer during normal business hours. You must be able to present your Owner-Warranty I.D. Card upon dealer's request.

The remedy for breach of this warranty is expressly limited to the repair or replacement, without charge for parts and labor, of any part that proves to be defective, and does not extend to liability for consequential damages, costs or expenses, including loss of time, inconvenience or loss of use of the vehicle, resulting from any part that proves to be defective. **ANY IMPLIED WARRANTY RELATING TO THIS RADIO, INCLUDING WARRANTIES OR MERCHANTABILITY OR FITNESS FOR A PARTICULAR PURPOSE, IS EXPRESSLY LIMITED TO TWELVE (12) MONTHS.**

(Some states place limitations on the length of an implied warranty or on the exclusion of limitations of incidental or consequential damages, so the above limitations or exclusions may not apply to you.)

NOTES

NOTES

NOTES

NOTES

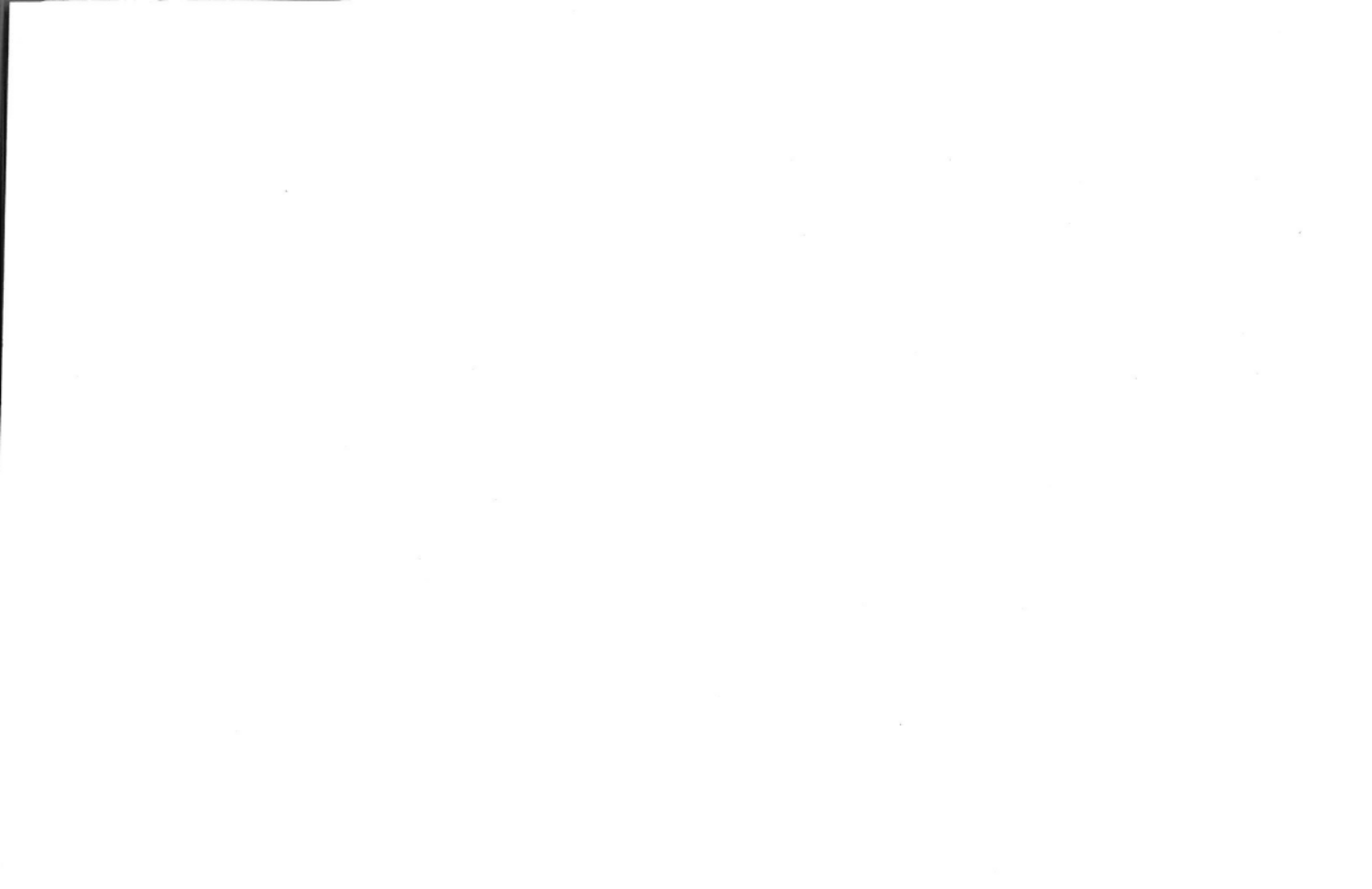

RSI PN 1741-0058P001
H-D PN 99464-89
PRINTED IN U.S.A.



Harley-Davidson, Inc.
Milwaukee, WI 53201



* 9 9 4 6 4 - 8 9 *