



Harley-Davidson, Inc.

---

# **XR-750**

# **PARTS CATALOG**

---

1972 thru 1989



Part No. 99442-89RA

# TABLE OF CONTENTS

	Page
Air Filter .....	10
Breather .....	6
Cables, Throttle and Clutch Control .....	15, 17
Cams .....	7
Carburetor, Air Filter, Exhaust System .....	10
Chains, Sprockets .....	14
Clutch .....	14, 15
Clutch Control .....	17
Connecting Rods, Flywheels .....	4
Crankcase .....	5, 6
Cylinders and Cylinder Heads .....	2, 3
Decals .....	17
Elbows, Hose Fittings .....	18
Exhaust System .....	10
Flywheels, Connecting Rods .....	4
Footrests .....	16
Fuel Tank .....	17
Gaskets, Seals, O-Rings .....	1
Gearcase and Gears .....	7
Hardware Listing .....	21
Hose Clamps .....	18
Hose Fittings .....	18
Hoses .....	17
Hub, Front Wheel .....	16
Idler Gear (Ignition) .....	11
Ignition, Spark Plugs .....	10
Number Plate .....	18
Numerical Index .....	28
Oil Pump .....	8, 9
Oil Sump .....	6
Oil Tank .....	17
O-Rings .....	1
Piston and Rings .....	3
Rear Fork Parts .....	16
Rocker Cover and Components .....	2, 3
Seat .....	16
Seals .....	1
Service Manual .....	18
Shifter .....	13
Spark Plugs, Ignition .....	10
Sprockets, Chains .....	14
Steering Head Parts .....	16
Suppliers .....	19, 20
Tachometer Drive Parts .....	18
Throttle and Clutch Control .....	17
Transmission .....	11, 12
Valves .....	2, 3

## PATENT NOTICE

Harley-Davidson products are manufactured under one or more of the following patents: U.S. Patents — 2986162, 2987934, 2998809, 3116089, 3144631, 3144860, 3226994, 3229792, 3434887, 3559773, 3673359, 3680403, 3683716, 3709317, Des. 225,626.

To the best knowledge of Harley-Davidson, Inc., the material contained herein is accurate as of the date this publication was approved for printing. Harley-Davidson, Inc., reserves the right to change specifications, equipment, or designs at any time without notice and without incurring obligation.

HARLEY-DAVIDSON, INC.  
Milwaukee, Wisconsin 53201

COPYRIGHT 1990 BY HARLEY-DAVIDSON, INC., ALL RIGHTS RESERVED

Printed in U.S.A.

PART NO.	NAME	USED ON
----------	------	---------

### GASKETS, SEALS AND O-RINGS

11100	O-RING, tappet guide (4)	72 to *
11105	O-RING, rocker arm shaft — left (4)	88 to *
11110	O-RING, rocker arm shaft — left (4)	72 thru 87
11115	O-RING, rocker arm shaft — right (4)	72 to *
11159	O-RING, oil pump upper cover (2)	88 to *
12021	OIL SEAL, clutch gear/release rod	83 to *
12023	OIL SEAL, push rod cover (8)	72 to *
12043	OIL SEAL, rotor shaft	88 to *
16774—72R	GASKET, cylinder base (2)	72 to *
18071—72R	OIL SEAL, valve stem (4)	72 to *
24776—88R	OIL SEAL, crankshaft — left	88 to *
24821—74RA	GASKET, sump	75 to *
25224—52A	GASKET, gearcase cover	72 to *
25535—74R	OIL SEAL, pinion shaft — gear cover	75 to *
26227—58	OIL SEAL, oil pump (2—1975 & later)	72 to *
26256—72R	GASKET, body — upper cover	72 thru 87
26258—52	GASKET, body — lower cover	72 thru 87
26259—72R	GASKET, oil pump to crankcase	72 thru 87
27015—72R	GASKET, carburetor manifold to cylinder head (2)	72 thru 87
32522—37	GASKET, tachometer drive assembly mounting	72 to *
34035—52	OIL SEAL, shifter shaft	72 to *
34952—52	GASKET, front chain cover	72 to *
35150—52	OIL SEAL AND RETAINER, transmission mainshaft — right	72 thru 83
35151—52A	OIL SEAL, transmission mainshaft — right	72 to *
35169—52	GASKET, transmission mainshaft oil seal retainer	72 thru 83
37742—83R	OIL SEAL, clutch hub	83 to *
37762—52	GASKET, clutch cover	72 to *
60567—36	GASKET, chain hole inspection cover	72 thru 87
67142—52	GASKET, valve adjusting plug (4)	72 to *
83162—51	OIL SEAL, crankshaft — left	75 thru 87

PART NO.	NAME	USED ON
-------------	------	---------

**CYLINDERS, CYLINDER HEADS, ROCKER COVERS AND VALVES**

858	BOLT, rocker arm cover — 5/16-18 × 2-3/4 (4)	72 to *
3206B	SET SCREW, rocker arm shaft — No. 8-32 × 3/16 socket hd. (4)	72 to *
4017	BOLT, tappet guide — 5/16-18 hex hd. (4)	72 to *
4086	BOLT, rocker arm cover — 5/16-18 × 3 hex hd. (4)	72 to *
4392	BOLT, rocker arm cover — 5/16-18 × 3-1/4 hex hd. (10)	72 to *
6016	WASHER, rocker arm cover bolt — 11/32 × 11/16 × 1/16 (18)	72 to *
6470R	WASHER, cylinder head to cylinder — 7/16 × 15/16 × 3/16 (8)	72 to *
6486HW	WASHER, rocker shaft — 7/16 × 13/16 × 3/32 (4)	75 thru 87
6530	WASHER, rocker arm shaft nut (4)	88 to *
7837W	NUT, rocker shaft — 7/16-20 × 3/8 × 11/16 hex (4)	75 thru 87
7845	NUT, rocker arm shaft (4)	88 to *
11100	O-RING, tappet guide (4)	72 to *
11105	O-RING, rocker arm shaft — left (4)	88 to *
11110	O-RING, rocker arm shaft — left (4)	75 thru 87
11115	O-RING, rocker arm shaft — right (4)	72 to *
12023	OIL SEAL, push rod cover (8)	72 to *
16304—87	ELBOW — 90° (2)	88 to *
16472—88R	FRONT CYLINDER	88 to *
16474—88R	REAR CYLINDER	88 to *
16563—72R	LINER, cylinder (2)	72 to *
16602—30	NUT, cylinder head stud (8)	72 to *
16682—88R	FRONT CYLINDER HEAD	72 to *
16684—88R	REAR CYLINDER HEAD	72 to *
16571—77R	GASKET SHIM, cylinder base — 0.010" thick aluminum (brown) (2)	72 to *
16572—77R	GASKET SHIM, cylinder base — 0.015" thick aluminum (pink) (2)	72 to *
16679—89R	CYLINDER HEAD KIT, front — unassembled	72 to *
16680—89R	CYLINDER HEAD KIT, rear — unassembled	72 to *
16774—72R	GASKET, cylinder base (2)	72 to *
16818—72R	SHIM, lower valve spring collar — 0.015" thick	72 to *
16819—72R	SHIM, lower valve spring collar — 0.030" thick	72 to *
16820—72R	SHIM, lower valve spring collar — 0.060" thick	72 to *
16830—83R	STUD, cylinder (8)	72 to *
17402—79RB	ROCKER ARM, rear intake — No. 1	72 to *
17403—79RB	ROCKER ARM, rear exhaust — No. 2	72 to *
17404—79RB	ROCKER ARM, front intake — No. 3	72 to *
17405—79RB	ROCKER ARM, front exhaust — No. 4	72 to *
17428—72R	NEEDLE BEARING, rocker arm (8)	72 to *
17390—83	SHAFT, rocker arm (4)	75 thru 87
17435—88R	SHAFT, rocker arm (4)	88 to *
17436—74R	SPACER, rocker shaft (4)	75 to *
17451—72R	SHIM, rocker shaft — 0.007	72 to *
17452—72R	SHIM, rocker shaft — 0.015	72 to *
17453—72R	SHIM, rocker shaft — 0.036	72 to *
17514—74R	COVER, rocker arm — front	75 thru 87
17514—88R	COVER, rocker arm — front	88 to *
17515—74R	COVER, rocker arm — rear	75 thru 87
17515—88R	COVER, rocker arm — rear	88 to *
17910—88R	PUSH ROD — long, without ends (2)	72 to *
17916—77R	PUSH ROD TIP (8)	72 to *
17917—88R	PUSH ROD — short, without ends (2)	72 to *
17935—88R	COVER, push rod (4)	75 to *
17951—72R	PLUG, valve adjusting (4)	72 to *
18054—72RA	INSERT, exhaust valve seat — 0.040" O.S. (2)	72 to *
18060—72RA	INSERT, intake valve seat — 0.040" O.S. (2)	72 to *

PART NO.	NAME	USED ON
----------	------	---------

### CYLINDERS, CYLINDER HEADS, ROCKER COVERS AND VALVES (CONT'D.)

18068-74R	INTAKE VALVE, 44mm. (2)	72 to *
18067-82R	INTAKE VALVE, 45mm. (2)	72 to *
18071-72R	VALVE STEM SEAL (4)	72 to *
18081-76R	EXHAUST VALVE, 37mm. (2)	72 to *
18083-82R	EXHAUST VALVE, 38mm. (2)	72 to *
18150-84R	VALVE GUIDE, intake — standard (2)	72 to *
18152-84R	VALVE GUIDE, intake — 0.002" O.S. (2)	72 to *
18154-84R	VALVE GUIDE, intake — 0.004" O.S. (2)	72 to *
18159-84R	VALVE GUIDE, intake — 0.009" O.S. (2)	72 to *
18160-84R	VALVE GUIDE, exhaust — standard (2)	72 to *
18162-84R	VALVE GUIDE, exhaust — 0.002" O.S. (2)	72 to *
18164-84R	VALVE GUIDE, exhaust — 0.004" O.S. (2)	72 to *
18169-84R	VALVE GUIDE, exhaust — 0.009" O.S. (2)	72 to *
18200-79R	VALVE SPRING, inner & outer pair (4)	80 to *
18220-79R	COLLAR, valve spring — lower (4)	80 to *
18221-79R	COLLAR, valve spring — upper (4)	80 to *
18228-66RA	KEY, upper valve collar	80 to *

THE FOLLOWING SHIMS CAN BE USED FOR THE SHIMMING OF INDIVIDUAL VALVE SPRINGS OF PRE-1986XL AND PRE-1978XR 750 ENGINES.

18241-67R	SHIM, inner valve spring — 0.007" thick	72 thru 76
18242-67R	SHIM, inner valve spring — 0.015" thick	72 thru 76
18243-67R	SHIM, inner valve spring — 0.036" thick	72 thru 76
18245-67R	SHIM, outer valve spring — 0.007" thick	72 thru 76
18246-67R	SHIM, outer valve spring — 0.015" thick	72 thru 76
18247-67R	SHIM, outer valve spring — 0.036" thick	72 thru 76

18508-72RA	TAPPET ASSEMBLY (4)	72 to *
18534-29A	TAPPET ROLLER KIT (4)	72 to *
18607-74RA	TAPPET GUIDE (4)	72 to *
45830-48	PIPE PLUG — 1/8", rocker cover	88 to *
67142-52	GASKET, valve adjusting plug (4)	72 to *

### PISTON AND RINGS

22159-86R	PISTON — standard	72 to *
22286-86R	PISTON — 0.010" O.S.	72 to *
22287-86R	PISTON — 0.020" O.S.	72 to *
22288-86R	PISTON — 0.030" O.S.	72 to *
22289-86R	PISTON — 0.040" O.S.	72 to *

NOTE: PISTONS ARE SUPPLIED WITHOUT COMPONENTS.

22528-86RA	RING SET — standard (for 1 piston)	86 to *
22529-86RA	RING SET — 0.010" O.S. (for 1 piston)	86 to *
22530-86RA	RING SET — 0.020" O.S. (for 1 piston)	86 to *
22531-86RA	RING SET — 0.030" O.S. (for 1 piston)	86 to *
22532-86RA	RING SET — 0.040" O.S. (for 1 piston)	86 to *
22720-86RA	PISTON PIN (2)	86 to *
24702-72R	RETAINING RING, piston pin (4)	72 thru 85
24702-86R	RETAINING RING, piston pin (4)	86 to *

PART NO.	NAME	USED ON
----------	------	---------

**FLYWHEELS AND CONNECTING RODS**

9481RA	ROLLER, crankpin — standard (28)	72 thru 87
9484RA	ROLLER, crankpin — 0.0005" O.S. (28)	72 thru 87
9486RA	ROLLER, crankpin — 0.0010" O.S. (28)	72 thru 87
9487RA	ROLLER, crankpin — 0.0015" O.S. (28)	72 thru 87
9488RA	ROLLER, crankpin — 0.0020" O.S. (28)	72 thru 87
9501RA	ROLLER, crankpin — standard. (14)	72 thru 87
9504RA	ROLLER, crankpin — 0.0005" O.S. (14)	72 thru 87
9506RA	ROLLER, crankpin — 0.0010" O.S. (14)	72 thru 87
9507RA	ROLLER, crankpin — 0.0015" O.S. (14)	72 thru 87
9508RA	ROLLER, crankpin — 0.0020" O.S. (14)	72 thru 87
16243—88R	THRUST WASHER, flywheel .040 (2)	88 to *
16244—88R	THRUST WASHER, flywheel .045 (2)	88 to *
16245—88R	THRUST WASHER, flywheel .050 (2)	88 to *
16246—88R	THRUST WASHER, flywheel .055 (2)	88 to *
23754—89R	FLYWHEEL, right — balanced	88 to *
23755—89R	FLYWHEEL, left — balanced	88 to *
23756—89R	FLYWHEEL, left — balanced	72 thru 87
23757—89R	FLYWHEEL, right — balanced	72 thru 87
23947—87R	CRANKPIN — standard	72 thru 87
23947—88R	CRANKPIN — standard	88 to *
23973—87R	CRANKPIN — 0.002" O.S.	72 thru 87
23977—88R	CRANKPIN — 0.001" O.S.	88 to *
23978—88R	CRANKPIN — 0.002" O.S.	88 to *
23962—87R	PLUG, crankpin — 3/4 dia. (2)	87
23962—88R	PLUG, crankpin (2)	88 to *
24324—88R	CONNECTING ROD — front	88 to *
24325—88R	CONNECTING ROD — rear	88 to *

NOTE: —88R CONNECTING RODS ARE SUPPLIED WITH INSTRUCTIONS AND CAN BE USED IN OLDER ENGINES.  
FLYWHEELS WITH PART NO. 23756—89R AND 23757—89R NEED 0.002" OVERSIZE CRANKPIN

24331—36	BUSHING, piston pin — standard (2)	72 to *
24332—36	BUSHING, piston pin — 0.010" O.S. (2)	72 to *
24363—55RB	RETAINER, rear connecting rod (2)	72 thru 87
24365—55RB	RETAINER, front connecting rod (2)	72 thru 87
24381—88R	BEARING SET, front rod	88 to *
24382—88R	BEARING SET, rear rod (2)	88 to *
24776—88R	OIL SEAL, crankshaft — left	88 to *
24777—83R	RETAINER, seal (use with seal, 83162—51) double row main bearing	83 thru 87
24777—88R	RETAINER, crankshaft seal, left	88 to *
35367—72RA	THRUST WASHER, flywheel — 0.105" thick	72 thru 87
35368—72RA	THRUST WASHER, flywheel — 0.110" thick	72 thru 87
35369—72RA	THRUST WASHER, flywheel — 0.115" thick	72 thru 87
35370—72RA	THRUST WASHER, flywheel — 0.120" thick	72 thru 87
35374—72RA	THRUST WASHER, flywheel — 0.045" thick	72 thru 87
35375—72RA	THRUST WASHER, flywheel — 0.050" thick	72 thru 87
35376—72RA	THRUST WASHER, flywheel — 0.055" thick	72 thru 87
35377—72RA	THRUST WASHER, flywheel — 0.060" thick	72 thru 87
35409—74R	THRUST WASHER, pinion shaft	72 to *
83162—51	SEAL, flywheel — left side	72 thru 87

PART NO.	NAME	USED ON
<b>CRANKCASE</b>		
358	DOWEL PIN, crankcase halves (2)	72 to *
375	DOWEL PIN, right crankcase (4)	72 to *
707	DRAIN PLUG	75 thru 87
718	DRAIN PLUG, magnetic	88 to *
720	PLUG, timing hole	72 to *
2269W	SCREW, chain hole cover — No. 12-24 × 1/2 oval ctsk. hd. (2)	72 thru 87
2851	BOLT, front chain adjuster — 3/8-16 × 7/8 hex hd. (2)	72 to *
2879W	BOLT, engine upper — rear — 3/8-16 × 1 hex hd. (4)	72 to *
2881W	BOLT, oil pump mounting — 1/4-20 × 2 hex hd. (5)	75 thru 87
2882W	BOLT, shift lever stop — 5/16-19 × 5/8 hex hd. (2)	72 to *
3429	BOLT, oil pump mounting — 1/4-20 × 2-3/4 hex hd. (5)	88 to *
3720	BOLT, chain cover — oil level — 1/4-28 × 7/16 hex hd.	72 thru 87
4067	BOLT, right crankcase — 5/16-18 × 4-7/16 hex hd.	72 to *
4068	BOLT, right crankcase — 5/16-18 × 2-3/8 hex hd. (3)	72 to *
4072	SCREW, main bearing retaining plate — No. 10-24 × 3/4 flat socket ctsk. hd. (4)	83 to *
4100HW	BOLT, right crankcase — 5/16-18 × 4 hex hd. (2)	72 to *
4413	BOLT, engine front mount — 5-1/2 lg. (2)	72 to *
4720	SCREW, crankcase rear (3)	88 to *
4815	SCREW, primary chain cover (9)	88 to *
	motor sprocket access cover (4)	88 to *
6016	WASHER, rocker cover screw — 11/32 × 11/16 × 1/16 (18)	72 to *
6220W	WASHER, chain cover — oil level bolt — 1/4 × 7/16 × 1/32	72 thru 87
6236B	WASHER, primary chain cover (9)	80 to *
6701	WASHER, rear engine mount (7)	88 to *
6703	WASHER, clutch spring (6)	83 to *
	oil pump screw (5)	72 to *
	motor sprocket access cover (4)	88 to *
7036	LOCKWASHER, oil pump mounting (5)	72 to *
	motor sprocket access cover (4)	88 to *
	primary chain cover (9)	88 to *
7038	LOCKWASHER, engine rear mounting — upper and lower — 3/8 (4)	72 to *
7041	LOCKWASHER, shift lever stop bolt — 5/16 (2)	72 to *
7775	LOCKNUT, engine front and rear mounting — 3/8-24	72 to *
9028R	BEARING, cam gear shaft (3)	72 to *
9098R	ROLLER BEARING, sprocket and gearshaft	72 thru 87
11052	SNAP RING, main bearing — left	88 to *
16212—59R	ENGINE FRONT MOUNTING PLATE (aluminum) (2)	72 to *
16218—52	WASHER, engine front mount (8)	72 to *
16230—59R	SPACER, engine front mounting (aluminum) (2)	72 to *
16237—57	BOLT, engine front mount — 6-13/16 lg. (2)	72 to *
16830—83R	STUD, cylinder to crankcase — 8-1/4 lg. (8)	72 to *
17454—72R	SCREW, primary chain cover — 1/4-20 × 5/8 socket hd. (9)	75 thru 76
24221—51	NEEDLE BEARING, cam shaft (4)	75 to *
24380—88R	ROLLER BEARING, sprocket and gear shaft (2)	88 to *
24512—88R	SET OF CRANKCASES	88 to *
24552—88R	BUSHING, crankcase left	88 to *
24702—52R	RETAINING RING, sprocket and gear shaft main bearing (2)	75 thru 87
24777—83R	RETAINER, sprocket shaft seal	83 thru 87
24777—88R	RETAINER, crankshaft seal — left	88 to *
24975—37	OIL STRAINER	72 & 75
33080—83R	PLATE, retaining — main bearing — right	83 to *
34037—52	BUSHING, shift shaft	72 to *

PART NO.	NAME	USED ON
----------	------	---------

### CRANKCASE (CONT'D)

34844—57B	ACCESS DOOR, transmission .....	72 to *
34946—88R	ACCESS COVER, motor sprocket .....	88 to *
34947—89R	FRONT CHAIN COVER .....	88 to *

NOTE: PART NO. 34947—89R FRONT CHAIN COVER DOES NOT INCLUDE MOTOR SPROCKET ACCESS COVER.

34949—64	FRONT CHAIN COVER, complete .....	72 thru 87
34952—52	GASKET, front chain cover .....	72 to *
60567—36	GASKET, chain hole cover .....	72 thru 87
60570—64	INSPECTION COVER, primary chain .....	72 thru 87
62702—52	WASHER, drain plug (2; 1-1975 & later) .....	72 thru 87

### BREATHER, CRANKCASE

9964	CLAMP, vent line (3) .....	88 to *
24937—88R	HOSE FITTING, cam gear cover .....	88 to *
52590—77A	CLAMP, baffle hose (2) .....	88 to *
63514—88R	HOSE, baffle .....	88 to *
63516—88R	BAFFLE .....	88 to *
63517—88R	HOSE END, baffle (2) .....	88 to *
63519—88R	HOSE, vent line — 5/8 I.D. × 4 ft. long .....	88 to *

### OIL SUMP

852	SCREW, sump — 1/4-20 × 1 socket hd. (2) .....	75 to *
2664	SCREW, sump windage tray — No. 10-24 × 7/16 Pozidriv pan hd. (2) .....	75 to *
6218W	WASHER, sump mounting — 1/4 × 7/16 × 1/32 brass (4) ..	75 to *
6716	WASHER, sump windage tray — No. 10 × 1/2 × 3/64 (2) ...	75 to *
6778	WASHER, fiber .....	88 to *
7069	LOCKWASHER, sump windage tray — No. 10 (2) .....	75 to *
16302—81	HOSE FITTING — 45° elbow (2) .....	88 to *
16304—87	ELBOW — 90° .....	88 to *
24821—74RA	GASKET, oil sump .....	75 to *
24996—72RA	SUMP, oil .....	88 to *
24998—74R	WINDAGE TRAY, oil sump — baffle .....	75 to *
24999—74R	SCREW, sump mounting — 1/4-20 × 2-3/4 socket hd. (2) ...	75 to *
63780—88R	FITTING, sump — with screen .....	88 to *



PART NO.	NAME	USED ON
----------	------	---------

## GEARCASE, GEARS AND CAMS

1793R	SCREW, gearcase cover — 1/4-20 × 2-1/4 socket hd. (3) . . .	75 thru 87
1793R	SCREW, gearcase cover — 1/4-20 × 2-1/4 socket hd. (2) . . .	88 to *
1795	SCREW, gearcase cover — 1/4-20 × 3 socket hd. (2) . . . . .	75 thru 87
1797R	SCREW, gearcase cover — 1/4-20 × 2 socket hd. (2) . . . . .	75 to *
3231B	SET SCREW, 1/4-20 × 1/4 socket hd. (plug for cam cover) . . .	75 to *
3478	SCREW, gearcase cover — 1/4-20 × 2-1/2 socket hd. . . . .	72 to *
3482	SCREW, gearcase cover — 1/4-20 × 1-1/4 socket hd. (3) . . .	75 to *
9017	BALL BEARING, No. 2 cam — outer . . . . .	75 to *
9028R	BALL BEARING, cam gear shaft — cover (3) . . . . .	72 to *
24011—67RA	PINION GEAR (green) . . . . .	88 to *
24004—88R	PINION GEAR (white) . . . . .	88 to *
24007—88R	PINION GEAR (red) . . . . .	88 to *
24221—51	NEEDLE BEARING, cam shaft (4) . . . . .	75 to *
24937—88R	HOSE FITTING, gearcase vent . . . . .	88 to *
25198—88R	COVER, cam gears . . . . .	88 to *
25200—74R	COVER, cam gears . . . . .	75 thru 87
25224—52A	GASKET, gearcase cover . . . . .	72 to *
25234—53R	RESTRICTOR PLUG, gearcase cover . . . . .	72 to *
25507—88R	PIN, gear drive (2) . . . . .	88 to *
25518—74R	SHAFT, cam gear — No. 1, 3, 4 . . . . .	75 thru 87
25519—74R	SHAFT, cam gear — No. 2 . . . . .	75 thru 87
25535—74R	SEAL, pinion shaft — gear cover . . . . .	75 to *
25567—88R	SHAFT, No. 1, 3 & 4 cam (3) . . . . .	88 to *
25568—88R	SHAFT, No. 2 cam . . . . .	88 to *
25569—88R	GEAR, No. 1, 2, 3 & 4 cam (green) (4) . . . . .	88 to *
29699—88R	GEAR, No. 1, 2, 3 & 4 cam (white) (4) . . . . .	88 to *
29700—88R	GEAR, No. 1, 2, 3 & 4 cam (red) (4) . . . . .	88 to *
25570—88R	GEAR, No. 2 & 4 cam (green) (2) . . . . .	88 to *
29701—88R	GEAR, No. 2 & 4 cam (white) (2) . . . . .	88 to *
29702—88R	GEAR, No. 2 & 4 cam (red) (2) . . . . .	88 to *
25571—88R	CAM LOBE, intake (2) . . . . .	88 to *
25572—88R	CAM LOBE, exhaust (2) . . . . .	88 to *
25592—74R	NEEDLE BEARING, pinion shaft . . . . .	75 to *
29615—39R	COVER, tachometer shaft hole . . . . .	72 to *
32522—37	GASKET, tachometer drive cover . . . . .	72 to *
34037—52	BUSHING, shift shaft . . . . .	72 to *
35409—74R	THRUST WASHER, pinion shaft . . . . .	75 to *
35412—74R	SHIM, cam — 0.075 . . . . .	75 to *
35413—74R	SHIM, cam — 0.070 . . . . .	75 to *
35414—74R	SHIM, cam — 0.065 . . . . .	75 to *
35415—74R	SHIM, cam — 0.060 . . . . .	75 to *
35416—74R	SHIM, cam — 0.055 . . . . .	75 to *
35417—74R	SHIM, cam — 0.050 . . . . .	75 to *
35418—74R	SHIM, cam — 0.045 . . . . .	72 to *

PART NO.	NAME	USED ON
<b>OIL PUMP 1/4 ENGINE SPEED — 75 THRU 87</b>		
2881W	BOLT, oil pump mounting — 1/4-20 x 2 hex hd. (5)	75 thru 87
7036	LOCKWASHER, oil pump mounting — 1/4 (5)	72 to *
26203—74R	OIL PUMP ASSEMBLY, 1/4 engine speed	75 to *
	603 PIN	
	8873 BALL BEARING, check valve	
	26217—74R BODY, oil pump	
	26227—58 OIL SEAL (2)	
	26241—74R COVER, upper	
	26250—56 COVER, lower	
	26256—72R GASKET, body — upper cover	
	26258—52 GASKET, body — lower cover	
	26317—72A IDLER GEAR, scavenger	
	26320—72R DRIVE GEAR, scavenger	
	26322—52A IDLER GEAR, pressure	
	26323—52A DRIVE GEAR, pressure	
	26327—52 IDLER SHAFT	
	26331—74R GEAR SHAFT	
	26340—36 KEY, breather valve gear	
	26341—37 WASHER, split — scavenger gear (2)	
	26364—57 SPRING, check valve	
	26420—74R END PLUG, check valve	
	63533—41 FITTING, 3/8" oil hose (steel)	
26259—72R	GASKET, oil pump to crankcase	72 to *
26318—54R	DRIVE GEAR, oil pump — pinion shaft — 1/4 engine speed	72 to *

ITEM NO.	PART NO.	NAME	USED ON
<b>OIL PUMP 1/2 ENGINE SPEED — 88 to *</b>			
	26203—88R	OIL PUMP ASSEMBLY, 1/2 engine speed	88 to *
12	637R	DRIVE PIN, feed gear	
8	721	PIPE PLUG, 1/4" lower cover (2)	
24	3429	SCREW (5)	
22	6703	WASHER (5)	
23	7036	LOCKWASHER (5)	
20	8873	BALL, check valve	
15	11159	O-RING, upper cover (2)	
16	26217—88R	BODY, oil pump	
4	26227—58	OIL SEAL (2)	
26	26250—88R	COVER, lower	
21	26317—88R	GEAR, scavenger idler	
9	26320—88R	GEAR, scavenger drive	
14	26322—88R	GEAR, feed idler	
3	26323—88R	GEAR, feed drive	
13	26327—88R	IDLER SHAFT	
5	26228—88R	COVER, upper	
2	26229—88R	SLEEVE, breather	
1	26331—88R	GEAR SHAFT	
10	26341—37	WASHER HALF (2)	
11	26340—36	KEY, scavenger gear drive	
19	26364—72	SPRING, check valve	
17	26420—74R	PLUG, oil pump ball check	
7	32463—88R	HOSE FITTING, 3/8" scavenger intake	
25	45830—48	PIPE PLUG, 1/8"	
18	62570—83	HOSE FITTING, 1/4" scavenger outlet	
6	63541—74R	HOSE FITTING, 1/8" feed intake	
	26316—83R	GEAR, oil pump drive pinion shaft	88 to *

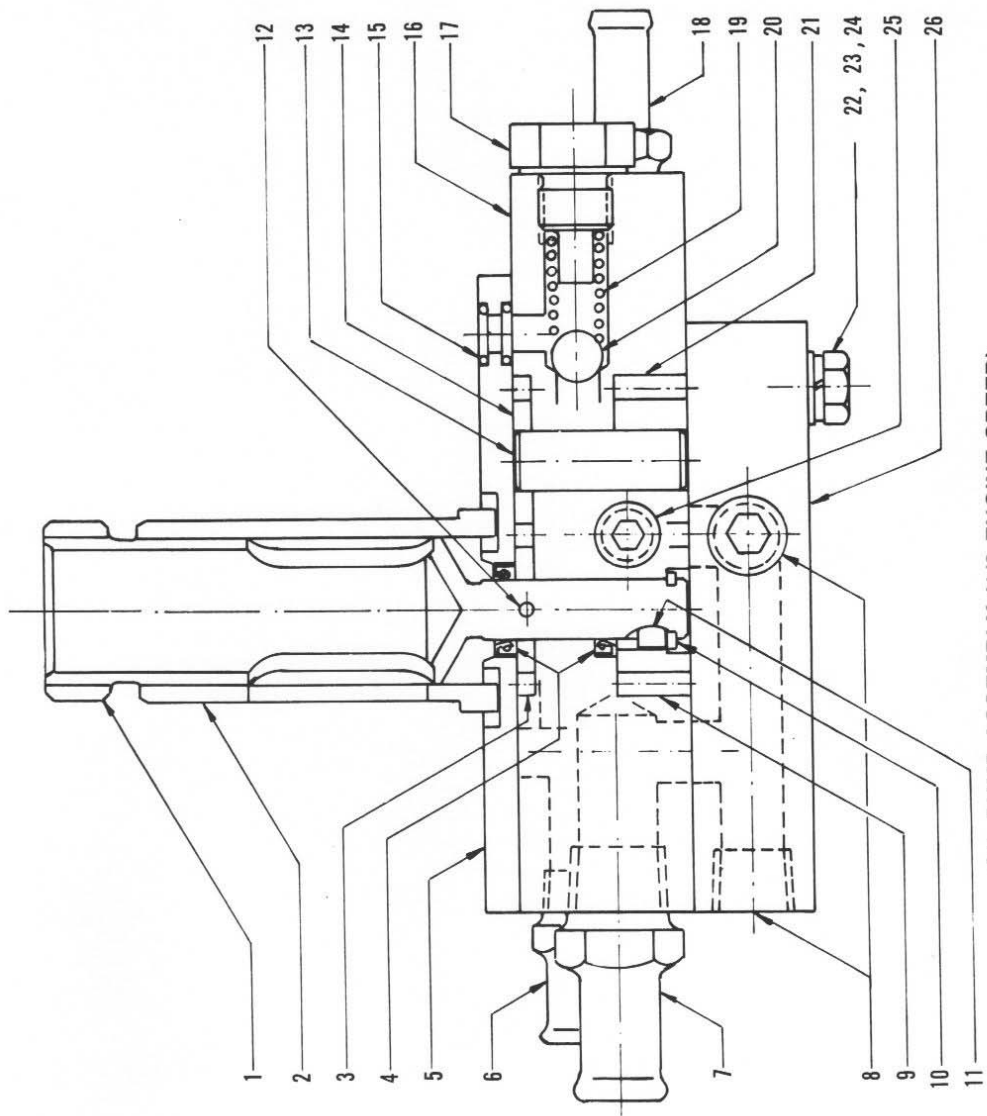

OIL PUMP ASSEMBLY (1/2 ENGINE SPEED)

PART NO.	NAME	USED ON
----------	------	---------

### CARBURETOR, AIR FILTER AND EXHAUST SYSTEM

3494	SCREW, manifold (4)	88 to *
9955	CLAMP, carburetor mounting (4)	72 thru 87
9956	CLAMP, air filter (2)	72 thru 87
27015-72R	GASKET, carburetor manifold to cylinder head (2)	72 thru 87
27015-88R	GASKET, intake manifold (2)	88 to *
27033-72RB	INTAKE MANIFOLD, front	80 thru 87
27033-88R	INTAKE MANIFOLD, front	88 to *
27036-72RB	INTAKE MANIFOLD, rear	80 thru 87
27036-88R	INTAKE MANIFOLD, rear	88 to *
27060-88R	CONNECTOR, carburetor to manifold (2)	88 to *
29000-86R	AIR FILTER (2)	72 to *
41835-57R	SPRING, exhaust pipe (2)	72 to *

### IGNITION AND SPARK PLUGS

744R	CAP, plastic, left housing	88 to *
852	SCREW, left housing	88 to *
1795	SCREW, housing, left to right (3)	88 to *
2659	SCREW, cover (6)	88 to *
3789A	SCREW, right housing	88 to *
6218W	WASHER (5)	88 to *
6716	WASHER, cover screw (6)	88 to *
7069	LOCKWASHER, cover screw (6)	88 to *
7812WA	NUT, rotor shaft (2)	88 to *
12043	OIL SEAL, rotor shaft (2)	88 to *
25507-88R	PIN, ignition gear drive	88 to *
25570-88R	GEAR, rotor shaft (green)	88 to *
29701-88R	GEAR, rotor shaft (white)	88 to *
29702-88R	GEAR, rotor shaft (red)	88 to *
29962-88R	STATOR, front cylinder	88 to *
29963-88R	STATOR, rear cylinder	88 to *
29971-88R	ROTOR, front cylinder	88 to *
29972-88R	ROTOR, rear cylinder	88 to *
29973-88R	COIL, ignition (2)	88 to *
31978-88R	BOOT, spark plug (4)	88 to *
31979-88R	TERMINAL, spark plug boot (4)	88 to *
32301-88R	SPARK PLUG, 10mm., Champion G55 (2)	88 to *
32304-88R	SPARK PLUG, 14mm., Champion N80 (2)	88 to *
32452-88R	HOUSING, right	88 to *
32453-88R	HOUSING, left	88 to *
32454-88R	ROTOR SHAFT	88 to *
32457-88R	SHIELD (2)	88 to *
32458-88R	END COVER (2)	88 to *
32459-88R	STUD, stator (6)	88 to *
32460-88R	NUT, stator (6)	88 to *
32461-88R	GROMMET (2)	88 to *
32462-88R	WASHER, rotor shaft nut (2)	88 to *
32507-89R	IGNITION KIT	88 to *
35357-82	SHIM, rotor shaft — .098"	88 to *
35358-82	SHIM, rotor shaft — .107"	88 to *
35359-82	SHIM, rotor shaft — .116"	88 to *
35360-82	SHIM, rotor shaft — .125"	88 to *
35961-52	NEEDLE BEARING, rotor shaft (2)	88 to *

PART NO.	NAME	USED ON
----------	------	---------

### IDLER GEAR

29691—50R	SCREW, intermediate gear stud (2)	72 to *
29692—78R	FLANGE, intermediate gear	72 to *
29693—78R	SHAFT, intermediate gear	72 to *
29694—56R	SPACER, megneto intermediate gear stud	72 to *
29698—56RA	GEAR, intermediate (green)	72 to *
29695—88R	GEAR, intermediate (white)	72 to *
29696—88R	GEAR, intermediate (red)	72 to *

### TRANSMISSION

612	ROLL PIN, sprocket cover — 3/32 × 3/4	72 to *
2660	SCREW, mainshaft oil seal retainer — No. 10-24 × 3/8 Poqidriv pan hd. (4)	75 thru 83
3991	BOLT, transmission access door — 5/16-18 × 7/8 hex hd. (4)	72 to *
7069	LOCKWASHER, mainshaft oil seal retainer — No. 10 (4)	72 thru 83
8975	BALL BEARING, mainshaft	72 to *
8888	NEEDLE BEARING, low gear countershaft	88 to *
8995	BALL BEARING, clutch gear	72 to *
12021	OIL SEAL, clutch gear (18, 19 & 20T only)	88 to *
24578—57	DOWEL PIN, access door (2)	72 to *
34844—57B	ACCESS DOOR, transmission	72 to *
34872—57A	SPROCKET COVER, complete	72 to *
34890—52	BOLT, sprocket cover — upper	72 to *
34891—52	BOLT, sprocket cover — lower	72 to *
35044—72RA	MAINSHAFT	72 to *
35047—53	NUT, transmission sprocket	72 to *
35050—52	LOCKWASHER, transmission sprocket nut	72 to *
35112—52	RETAINING RING, mainshaft ball bearing (2)	72 to *
35150—52	OIL SEAL AND RETAINER, mainshaft — right	72 thru 83
35151—52A	OIL SEAL, mainshaft — right	72 to *
35169—52	GASKET, mainshaft oil seal retainer	72 thru 83
35277—61R	LOW GEAR, mainshaft — 26T	72 to *
35277—52A	LOW GEAR, mainshaft — 27T	72 to *
35277—54R	LOW GEAR, mainshaft — 28T	72 to *
35296—56A	SECOND GEAR, mainshaft — 23T (use with 35750—58)	72 to *
35296—56R	SECOND GEAR, mainshaft — 23T (use with 35750—58R)	72 to *
35305—56A	THIRD GEAR, mainshaft — 20T (use with 35709—54A)	72 to *
35337—56	RETAINING RING, mainshaft third gear	72 to *
35343—73	THRUST WASHER, mainshaft — right — 0.030"	72 to *
35344—73	THRUST WASHER, mainshaft — right — 0.040"	72 to *
35351—52RB	THRUST WASHER, mainshaft — right — 0.062"	72 to *
35352—52RB	THRUST WASHER, mainshaft — right — 0.071"	72 to *
35354—52RB	THRUST WASHER, mainshaft — right — 0.080"	72 to *
35355—72RB	THRUST WASHER, mainshaft — right — 0.089"	72 to *
35357—82	THRUST WASHER, mainshaft — right — 0.098"	72 to *
35358—82	THRUST WASHER, mainshaft — right — 0.107"	72 to *
35359—82	THRUST WASHER, mainshaft — right — 0.116"	72 to *
35360—82	THRUST WASHER, mainshaft — right — 0.125"	72 to *
35361—56	THRUST WASHER, mainshaft — left (pressed into clutch gear)	72 to *
35364—56	WASHER, mainshaft third gear	72 to *
35605—88R	SPACER, countershaft	88 to *
35606—88R	RING, retaining — countershaft	88 to *
35613—58	COUNTERSHAFT	72 thru 87
35613—88R	COUNTERSHAFT	88 to *

PART NO.	NAME	USED ON
<b>TRANSMISSION (CONT'D)</b>		
35695-58R	DRIVE GEAR, countershaft — 25T .....	72 to *
35695-60R	DRIVE GEAR, countershaft — 26T .....	72 to *
35695-58	DRIVE GEAR, countershaft — 27T .....	72 to *
35709-54B	THIRD GEAR, countershaft — 23T .....	72 to *
35750-58A	SECOND GEAR, countershaft — 20T .....	72 to *
35750-58R	SECOND GEAR, countershaft — 22T .....	72 to *
35760-54RA	LOW GEAR, countershaft — 17T (use with 35277-52A or 35277-54R) .....	72 thru 87
35760-61R	LOW GEAR, countershaft — 17T (use with 35277-61R) .....	72 thru 87
35760-84A	LOW GEAR, countershaft — 17T (use with 35277-52A) .....	88 to *
35787-72	BUSHING, low gear .....	72 thru 87
35809-58	SPACER, countershaft drive gear .....	72 thru 87
35818-72	THRUST WASHER, countershaft — low gear — right — 0.020" .....	72 to *
35327-73	THRUST WASHER, countershaft — low gear — right — 0.025" .....	72 to *
35819-72	THRUST WASHER, countershaft — low gear — right — 0.030" .....	72 to *
35328-73	THRUST WASHER, countershaft — low gear — right — 0.035" .....	72 to *
35821-72	THRUST WASHER, countershaft — low gear — right — 0.040" .....	72 to *
35329-73	THRUST WASHER, countershaft — low gear — right — 0.045" .....	72 to *
35820-52	THRUST WASHER, countershaft — low gear — right — 0.050" .....	72 to *
35821-52	THRUST WASHER, countershaft — low gear — right — 0.055" .....	72 to *
35824-52	THRUST WASHER, countershaft — low gear — right — 0.060" .....	72 to *
35825-52	THRUST WASHER, countershaft — low gear — right — 0.065" .....	72 to *
35828-52	THRUST WASHER, countershaft — low gear — right — 0.070" .....	72 to *
35829-52	THRUST WASHER, countershaft — low gear — right — 0.075" .....	72 to *
35840-52	THRUST WASHER, countershaft — low gear — left — 0.065" .....	72 thru 87
35836-55	THRUST WASHER, countershaft — low gear — left — 0.075" .....	72 thru 87
35838-55	THRUST WASHER, countershaft — low gear — left — 0.085" .....	72 thru 87
35839-55	THRUST WASHER, countershaft — low gear — left — 0.100" .....	72 thru 87
35841-58	THRUST WASHER, second gear .....	72 to *
35860-86	THRUST WASHER, countershaft — low gear — 0.055" (2) .....	88 to *
35861-86	THRUST WASHER, countershaft — low gear — 0.050" (2) .....	88 to *
35862-86	THRUST WASHER, countershaft — low gear — 0.045" (2) .....	88 to *
35863-86	THRUST WASHER, countershaft — low gear — 0.040" (2) .....	88 to *
35864-86	THRUST WASHER, countershaft — low gear — 0.035" (2) .....	88 to *
35865-86	THRUST WASHER, countershaft — low gear — 0.030" (2) .....	88 to *
35960-54	NEEDLE BEARING, countershaft (closed end) .....	72 to *
35961-52	NEEDLE BEARING, clutch gear and countershaft — left (access door) (2) .....	72 to *
37449-56	CLUTCH GEAR — 17T (use with 35695-58) .....	72 thru 87
37450-60R	CLUTCH GEAR — 18T (use with 35695-60R) .....	72 to *
37451-61R	CLUTCH GEAR — 19T (use with 35695-58R) .....	72 to *
37450-56R	CLUTCH GEAR — 20T (use with 35695-58R) .....	72 to *
37458-52	BUSHING, clutch gear .....	72 to *

PART NO.	NAME	USED ON
<b>SHIFTER</b>		
350	PIN, pawl lifter arm (2)	72 to *
4410	BOLT, shift lever to shaft — 1/4-28 × 7/8 hex hd.	77 to *
4621	BOLT, shifter cam — 7/16-14 × 1-1/28 hex hd.	72 to *
7036	LOCKWASHER, shift lever to shaft bolt — 1/4	72 to *
7041	LOCKWASHER, shift lever rubber — 5/16	72 to *
7753	NUT, shifter lever rubber — 5/16-24 × 1/4 × 1/2 hex	72 to *
9260	PIN, cam support (2)	72 to *
11036	RETAINING RING, shifter pawls (2)	72 to *
16825-48	PLUG, shifter shaft (expansion)	72 to *
34011-90R	SHIFTER CAM, only	72 to *
34035-52	OIL SEAL, shifter shaft	72 to *
34037-52	BUSHING, gear shaft shifter	72 to *
34040-52	RETAINING RING, shifter cam	72 to *
34062-52	SHIFTER PLUNGER	72 thru 83
34065-52	RETAINER, shifter plunger	72 thru 83
34067-52	LOCK, retainer — shifter plunger	72 to *
34068-52A	SPRING, shifter plunger	72 thru 83
34069-71	LOCK, shifter cam bolt	72 to *
34070-85R	RETAINER, shifter plunger	84 to *
34071-85R	SHIFTER PLUNGER	84 to *
34072-85R	SPRING, shifter plunger	84 to *
34141-52A	SHAFT, shifter fork	72 to *
34168-52	ROLLER, shifter finger (2)	72 to *
34291-52C	SHIFTER FORK (2)	72 to *
34292-72A	SHIFTER FORK, + 0.020	72 to *
34293-72A	SHIFTER FORK, - 0.020	72 to *
34461-72	SPACER, shifter pawl (2)	72 to *
34476-72	SHIFTER PAWL (2)	72 to *
34485-52	PLUG, carrier spring retainer (2)	72 to *
34494-74C	PAWL CARRIER ASSEMBLY	72 to *
34500-52A	PAWL CARRIER SPRING (2)	72 to *
34506-52A	PAWL LIFTER ARM, lower	72 to *
34507-52A	PAWL LIFTER ARM, upper	72 to *
34514-75A	PAWL CARRIER SUPPORT	72 to *
34606-52R	SHIFTER LEVER, only (splined)	72 to *
34609-52	RUBBER, shift lever	72 to *
34628-52R	SHAFT, shifter lever (splined)	72 to *
35336-74	THRUST WASHER, shifter cam	72 to *
35891-66	SHIM, pawl carrier support	72 to *
37224-90R	SPRING, shifter pawls	72 to *

PART NO.	NAME	USED ON
----------	------	---------

### SPROCKETS AND CHAINS

2851	BOLT, front chain adjuster — 3/8-16 × 7/8 hex hd. (2)	72 to *
6701	WASHER, front chain adjuster — 3/8 × 13/16 × 1/16 (2)	72 to *
7038	LOCKWASHER, front chain adjuster — 3/8 (2)	72 to *
23985—12	KEY, motor sprocket	72 to *
24003—41R	NUT, motor sprocket	72 to *
35047—53	NUT, transmission sprocket	72 to *
35050—52	LOCKWASHER, transmission sprocket nut	72 to *
39975—54A	FRONT CHAIN ADJUSTER, with lining and retainer	72 to *
39978—58	LINING, chain adjuster	72 to *
39979—58A	RETAINER, chain adjuster lining	72 to *
40002—52R	FRONT CHAIN, for 30T sprocket (Diamond)	72 to *
40005—52RA	FRONT CHAIN, for 25T sprocket (Diamond)	72 to *
40005—57	FRONT CHAIN, for 34T sprocket	72 to *
40008—52RA	FRONT CHAIN, for 20T sprocket (Diamond)	72 to *
40029—15E	REAR CHAIN (Diamond)	72 to *
40053—65	CONNECTING LINK, rear chain (press fit)	72 to *
40228—52R	MOTOR SPROCKET — 20T	72 to *
40233—52R	MOTOR SPROCKET — 25T	72 to *
40238—52R	MOTOR SPROCKET — 30T	72 to *
40238—64R	MOTOR SPROCKET — 34T	72 to *
41198—73	BOLT, rear wheel sprocket (5)	72 to *
41454—72R	REAR WHEEL SPROCKET — 36T	72 to *
41455—72R	REAR WHEEL SPROCKET — 37T	72 to *
41456—72R	REAR WHEEL SPROCKET — 38T	72 to *
41457—72R	REAR WHEEL SPROCKET — 39T	72 to *
41453—72R	REAR WHEEL SPROCKET — 40T	72 to *
41460—72R	REAR WHEEL SPROCKET — 41T	72 to *
41461—72R	REAR WHEEL SPROCKET — 42T	72 to *
41472—74R	REAR WHEEL SPROCKET — 43T	72 to *
41473—74R	REAR WHEEL SPROCKET — 44T	72 to *
41474—74R	REAR WHEEL SPROCKET — 45T	72 to *
41475—74R	REAR WHEEL SPROCKET — 46T	72 to *
41488—72R	ADAPTER, rear wheel sprocket	72 to *
35200—53R	TRANSMISSION SPROCKET — 15T	72 to *
35201—53R	TRANSMISSION SPROCKET — 16T	72 to *
35202—53R	TRANSMISSION SPROCKET — 17T	72 to *
35205—52RA	TRANSMISSION SPROCKET — 18T	72 to *
35197—52	TRANSMISSION SPROCKET — 19T	72 to *
35198—52	TRANSMISSION SPROCKET — 20T	72 to *
35205—52A	TRANSMISSION SPROCKET — 21T	72 to *
35205—54R	TRANSMISSION SPROCKET — 22T	72 to *
35198—53R	TRANSMISSION SPROCKET — 23T	72 to *
35198—58R	TRANSMISSION SPROCKET — 24T	72 to *

### CLUTCH

3	2613	SCREW, clutch cover — 10-24 × 1/4 (12)	72 to *
10	2881W	BOLT, clutch spring — 1/4-20 × 2 hex hd. (6)	84 to *
11	6703	WASHER, clutch spring — 1/4 × 5/8 × 1/16 (6)	84 to *
2	7220	LOCKWASHER, clutch cover (12)	72 to *
14	12021	SEAL, clutch gear	84 to *
24	33450—70R	SHIM, clutch spacing (as req'd)	72 to *
	34872—57A	COVER, complete, transmission sprocket	72 to *
	37201—54	RELEASE WORM AND LEVER	72 to *
	37210—47	COVER, release worm	72 to *
	37222—52	SPRING, release worm lever	72 to *
	37276—53	RELEASE ROD, right	72 to *
15	37280—85R	RELEASE ROD, left	84 to *
	37281—47	RELEASE ROD, left — center	72 to *
	37282—53	RELEASE ROD, right — center	72 to *



ITEM NO.	PART NO.	NAME	USED ON
----------	----------	------	---------

**CLUTCH (CONT'D.)**

13	37527-67	NUT, clutch hub	84 to *
12	37533-52A	LOCKWASHER, clutch hub	72 to *
25	37534-89R	INNER RACE, needle bearing clutch shell	84 to *
1	37631-83R	CLUTCH SHELL	84 to *
19	37632-83R	CLUTCH HUB	84 to *
21	37722-52	NEEDLE BEARING, clutch shell (2)	72 to *
22	37731-52	THRUST WASHER, clutch shell (2)	72 to *
20	37742-83R	OIL SEAL, clutch hub	84 to *
23	37758-83R	SPACER, clutch	84 to *
5	37760-88R	CLUTCH COVER	72 to *
4	37762-52	GASKET, clutch cover	72 to *
8	37761-83R	SPACER, clutch spring bolt (XR) (3)	84 to *
8	37763-88R	SPACER, clutch spring bolt (FL) (3)	88 to *
6	37876-52	RELEASING DISC	72 to *
17	37985-52A	DRIVE PLATE (fiber) (6)	72 to *
16	37992-52	DRIVEN PLATE (steel) (5)	72 to *
18	38016-88R	BACKING PLATE	72 to *
7	38076-53R	CLUTCH SPRING (XR spring) (3)	72 to *
7	38077-41	CLUTCH SPRING (FL spring) (3)	88 to *
9	38105-78R	SPRING CUP (6)	84 to *
	38130-54	ADJUSTING SCREW, clutch release worm	72 to *
	38135-50	LOCKNUT, adjusting screw clutch release worm	72 to *
	38619-57A	CABLE ASSEMBLY, clutch	72 to *

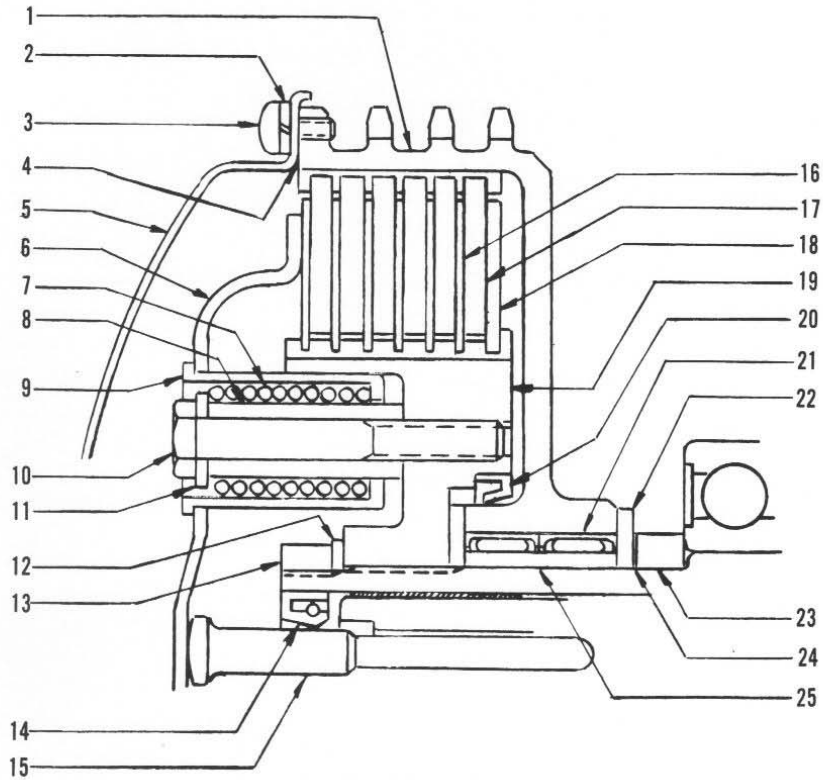

**CLUTCH ASSEMBLY**

PART NO.	NAME	USED ON
----------	------	---------

### HUB (FRONT WHEEL)

43077-78R	SPOKE NIPPLE (40)	75 to *
43078-78R	SPOKE, 19" rim (40)	75 to *
43318-78R	HUB WITH BEARINGS, complete (aluminum)	75 to *
43329-84R	BEARING (2)	75 to *

### REAR FORK AND STEERING HEAD PARTS

2660	SCREW, bearing locknut — No. 10-24 × 3/8 Pozidriv pan hd.	72 to *
7022	LOCKWASHER, rear fork pivot bolt — 5/8	72 to *
7069	LOCKWASHER, bearing locknut — No. 10	72 to *
7744	NUT, rear chain adjuster — 5/16-24 × 3/16 × 1/2 hex (2)	72 to *
7753	NUT, rear chain adjuster — 5/16-24 × 1/4 × 1/2 hex (2)	72 to *
39972-72R	ADJUSTER, rear chain (2)	72 to *
47511-52	PIVOT BOLT, rear fork	72 to *
47518-52	BEARING SPACER, inner	72 to *
47519-52	BEARING SHIELD (2)	72 to *
47525-52	LOCKWASHER, rear fork pivot bearing locknut	72 to *
47550-74	BEARING KIT, rear fork	72 to *
	Consists of:	
47512-74	NUT, pivot bolt	
47514-74	LOCKNUT, left bearing	
47515-74	LOCKNUT, right bearing	
47517-74	BEARING SPACER, outer	
47521-74	BEARING, rear fork (2)	
48302-85	STEERING HEAD BEARING — cone & cup (2)	72 to *
48315-60	BEARING CUP, steering head (Timken) (2)	72 to *
48371-70R	DUST SHIELD, steering head bearing (2)	72 to *

### FOOTRESTS

7739	LOCKNUT, pivot bolt	72 to *
7775	LOCKNUT, footrests stud	72 to *
34891-52	STUD, sprocket cover/foot peg support plate	72 to *
50939-52	FOOTREST ASSEMBLY (steel)	72 to *
50939-60R	FOOTREST ASSEMBLY (aluminum)	72 to *
50940-52	COVER, footrest	72 to *
50970-52	BOLT, footrest pivot	72 to *
50974-52R	STUD, footrest to support plate	72 to *

### SEAT

52002-74R	SEAT, complete with cover	75 to *
52050-70RA	SEAT COVER, only	72 to *

PART NO.	NAME	USED ON
-------------	------	---------

### THROTTLE AND CLUTCH CONTROL

1205	SCREW, handlever bracket clamp — No. 10-24 × 3/8 Pozidriv fil hd. (2)	72 to *
10006	CABLE STRAP, clutch cable	72 to *
11036	RETAINING RING, pivot pin	72 to *
38519—57A	CABLE ASSEMBLY, clutch	72 to *
38705—65	BRACKET, handlever	72 to *
45024—65A	HANDLEVER, with pins and nylon bushings	72 to *
45030—65A	CLAMP, handlever bracket	72 to *
45031—65	PIVOT PIN, handlever	72 to *
45034—68	ANCHOR PIN, handlever	72 to *
56209—74R	THROTTLE CONTROL GRIP, dual	72 to *
56359—88R	THROTTLE CABLE, front	72 to *
56360—88R	THROTTLE CABLE, rear	72 to *

### FUEL TANK

14166—87R	DECAL, "Harley-Davidson" 600R	72 to *
60998—70R	NAME TRANSFER, fuel tank — left	72 to *
60999—70R	NAME TRANSFER, fuel tank — right	72 to *
61103—36	FILLER CAP	72 to *
61571—74R	DECAL, "Harley-Davidson" — script (white)	72 to *
61601—79R	VALVE, shut-off — left	80 to *
61603—84R	VALVE, shut-off — right	80 to *
61634—62R	PAD, between tank and frame	72 to *
62762—52	RUBBER WASHER, fuel tank support (2)	72 to *

### OIL TANK

41835—30R	SPRING, oil tank mounting (2; 3-7/16" long)	72 to *
53254—74	PAD, oil tank (4)	72 to *
62625—70A	FILLER CAP, oil tank — with dipstick	72 to *

### HOSES

63519—88R	5/8 I.D. VENT HOSE (4 ft. long)	
	REINFORCED RUBBER HOSE IS SOLD IN BULK LENGTHS OF 25 FT. UNDER THE FOLLOWING PART NUMBERS:	
63501—68	1/4 I.D. × 1/2 O.D.	
63573—82	5/16 I.D. × 9/16 O.D.	
63500—68	3/8 I.D. × 5/8 O.D.	
63513—88R	1/2 I.D. × 3/4 O.D.	

PART NO.	NAME	USED ON
----------	------	---------

### HOSE CLAMPS

9946	.218 — .625
9969	.437 — .875
9964	.562 — 1.062
52590—77A	.812 — 1.500
10048	1.000 — 1.750
9955	1.062 — 2.000
9954	1.312 — 2.250
9991A	1.562 — 2.500
9956	2.062 — 3.000
10074	2.562 — 3.500
10058	3.062 — 4.000

PART NO.	TYPE	ENDS	I.D.
----------	------	------	------

### HOSE FITTINGS

16301—81	90°	.250 — 18 NPT MALE	FOR .500 I.D. HOSE	.344
16302—81	45°	.250 — 18 NPT MALE	FOR .375 I.D. HOSE	.344
16304—87	90°	.250 — 18 NPT MALE	FOR .375 I.D. HOSE	.297
24937—88R	STRAIGHT	.375 — 18 NPT MALE	FOR .625 I.D. HOSE	.470
26338—68	90°	.125 — 27 NPT MALE	.125 — 27 NPT FEMALE	.239
32463—88R	STRAIGHT	.375 — 18 NPT MALE	FOR .500 I.D. HOSE	.390
62375—57	90°	.125 — 27 NPT MALE	FOR .250 I.D. HOSE	.156
62570—83	STRAIGHT	.250 — 18 NPT MALE	FOR .375 I.D. HOSE	.297
63540—62	45°	.125 — 27 NPT MALE	FOR .375 I.D. HOSE	.250
63541—74R	STRAIGHT	.125 — 27 NPT MALE	FOR .375 I.D. HOSE	.250
63578—52	STRAIGHT	.125 — 27 NPT MALE	FOR .250 I.D. HOSE	.188
63580—66A	T	3 ENDS FOR .375 I.D. HOSE		.250
63780—75RA	STRAIGHT	.250 — 18 NPT MALE WITH SCREEN	FOR .375 I.D. HOSE	.300
63780—88R	STRAIGHT	.562 — 18 UNF MALE WITH SCREEN	FOR .500 I.D. HOSE	.390

PART NO.	NAME	USED ON
----------	------	---------

### TACHOMETER DRIVE

255	PIN, driven gear	72 to *
32531—36	DRIVEN GEAR, with 255 pin — 2:1 ratio	72 to *
32534—81R	DRIVEN GEAR, on No. 2 cam — 2:1 ratio	72 to *
92064—74R	DRIVE ASSEMBLY, tachometer — includes 4:1 driven gear	72 to *

### NUMBER PLATE

91737—60R	NUMBER PLATE (aluminum)	72 to *
-----------	-------------------------	---------

### SERVICE MANUAL

99491—89R	SERVICE MANUAL	80 to *
-----------	----------------	---------

## SUPPLIERS

WHEELS; FRONT FORK BRACKETS  
BRAKES (GREMECA/LOCKHEED)  
BRAKE DISC ROTORS WITH CARRIERS

CYLINDER HEAD GAS FLOWING AND  
RECONDITIONING  
FLAT SLIDE MIKUNI CARBURETORS  
DYNAMOMETER FACILITIES

CYLINDER HEAD MODIFICATION, CAMS

FRONT FORK ASSEMBLIES (CERIANI)  
EXHAUST SYSTEMS (SUPERTRAPP)  
REAR DISC BRAKE KITS  
REAR SHOCK ABSORBERS

EXHAUST SYSTEMS

FRONT FORK ASSEMBLIES (MARZOCCHI)  
BRAKE CALIPERS & MASTER CYLINDERS (GREMECA)  
TIRES; PIRELLI CHAINS; REGINA  
CARBURETORS; D'ELLORTO

FRAMES, REAR FORKS

FRAMES, REAR FORKS

BRAKE CALIPERS / MASTER CYLINDERS / BRAKE  
DISC ROTORS (BREMBO)

OIL (CASTROL)

KOZMAN  
340 FELL ST.  
SAN FRANCISCO, CA 94102  
415/861-4262

BRANCH FLOWMETRICS  
5556 CORPORATE DR.  
CYPRESS, CA 90623  
714/827-1463

CR AXTELL  
10949 TUXFORD ST. #17  
SUN VALLEY, CA 91352  
818/768-5595

STORZ PERFORMANCE  
1445 DUNLON ST. UNIT 18  
VENTURA, CA 93003  
805/654-8816

SUPERTRAPP  
3910 SEAPORT BLVD.  
W. SACRAMENTO, CA 95691  
916/372-5000

COSMOPOLITAN MOTORS  
JACKSONVILLE & MEADOWBROOK ROADS  
HATBORO, PA 19040  
215/672-9100

KNIGHT FABRICATIONS  
2185 E. BAKERVIEW #5  
BELLINGHAM, WA 98226  
206/676-9324

C&J RACING PRODUCTS  
1151 EAST MISSION  
FALLBROOK, CA 92028  
619/728-1707

SLATER BROTHERS  
P.O. BOX 1  
KENWOOD, CA 95452  
509/924-5131

CASTROL INC.  
CALL FOR LOCAL REPRESENTATIVE  
1500 VALLEY RD.  
WAYNE, NJ 07470  
201/633-2200

GASOLINE (PHILLIPS 66)

PHILLIPS 66 COMPANY  
632 ADAMS BLDG.  
BARTELSVILLE, OK 74004  
800/635-6066

CARBURETORS (MIKUNI)

MIKUNI AMERICAN  
8910 MIKUNI AVE.  
NORTHRIDGE, CA 91324  
213/873-2101

SHOCK ABSORBERS (WORKS PERFORMANCE)

WORKS PERFORMANCE  
8730 SHIRLEY AVE.  
NORTHRIDGE, CA 91324  
818/701-1010

SHOCK ABSORBERS (OHLINS)

NOLEEN RACING  
2141 E. PHILA ST. UNIT T  
ONTARIO, CA 91761  
714/947-5773

## HARDWARE LISTING

812	SCREW, 1/4-20 X 1-1/2 knurled socket hd. (chrome)	2216W	SCREW, No. 4-24 X 1/2 Phillips oval ctsk hd. (self-tapping)
813	SCREW, 1/4-20 X 1-3/4 knurled socket hd. (chrome)	2339	BOLT, No. 10-24 X 3/4 hex. hd. (Grade 2 steel)
852	SCREW, 1/4-20 X 1 knurled socket hd.	2417	SCREW, 1/4-28 X 5/8 Pozidriv truss hd. (Grade 2 steel)
854	SCREW, 3/8-24 X 2 knurled socket hd.	2420	SCREW, 1/4-20 X 3/4 Pozidriv truss hd. (Grade 2 steel)
855	SCREW, 3/8-16 X 2 knurled socket hd.	2432	SCREW, No. 10-24 X 5/16 Phillips truss hd. (black)
856	SCREW, 5/16-24 X 1 knurled socket hd.	2501	SCREW, No. 8-32 X 3/8 socket hd. (self-tapping)
857	SCREW, No. 10-24 X 3/8 knurled socket hd. (black)	2504	SCREW, No. 10-16 X 1-1/8 Pozidriv oval ctsk. hd. (self-tapping)
860	SCREW, 3/8-16 X 2 knurled socket hd. (black)	2507	SCREW, No. 6-32 X 7/16 Pozidriv pan hd. (Grade 2 steel)
864	SCREW, 1/4-20 X 7/16 socket pan hd.	2508	SCREW, No. 10-32 X 1/2 socket rd. hd. (black)
866	SCREW, 5/16-18 X 1-1/8 knurled socket hd.	2511	SCREW, No. 10-24 X 7/16 pan hd. (self-tapping)
867	SCREW, 1/2-13 X 1-1/2 knurled socket hd. (black)	2513	SCREW, 1/4-20 X 1-1/4 socket rd. hd. (black)
875	SCREW, 5/16-18 X 1 knurled socket hd.	2531	SCREW, No. 4-40 X 5/16 Pozidriv pan hd. (Grade 2 steel)
883	SCREW, 3/8-16 X 1-1/4 knurled socket hd.	2538	SCREW, 1/4-20 X 1 Pozidriv pan hd. (Grade 2 steel)
907	SCREW, No. 10-32 X 7/16 Pozidriv fillister hd. (w/lockpatch)(Grade 2 steel)	2551W	BOLT, 1/4-20 X 1 hex. hd. (Grade 5 steel)
909	SCREW, No. 10-24 X 1-1/4 Pozidriv pan hd. (w/lockpatch)(Grade 2 steel)	2574WA	SCREW, No. 6-32 X 1/4 oval hd.(w/lockwasher)
919	SCREW, 1/4-28 X 3/4 socket hd.	2576	SCREW, No. 10-32 X 3/4 Pan Hd.(Grade 2 steel)
920	SCREW, 5/16-24 X 7/8 knurled socket hd.(w/lockpatch)	2579	SCREW, No. 8-32 X 5/8 Pozidriv oval ctsk. hd. (Grade 2 steel)
922	SCREW, No. 6-32 X 3/4 Phillips hd. (black)	2581	SCREW, No. 10-24 X 1-5/8 Pozidriv pan hd. (Grade 2 steel)
923	SCREW, 1/4-20 X 21/32 socket pan hd.	2582	SCREW, 5/16-18 X 3/4 Pozidriv pan hd. (Grade 2 steel)
924	SCREW, 1/4-20 X 33/64 socket pan hd.	2583	SCREW, No. 10-32 X 5/16 Pozidriv pan hd. (Grade 2 steel)
933	SCREW, No. 10-32 X 15/16 Pozidriv truss hd. (Grade 2 steel)	2585	SCREW, No. 8-32 X 5/16 Pozidriv pan hd. (Grade 2 steel)
1040	SCREW, No. 8-32 X 1/4 fillister hd.	2587	SCREW, No. 6-32 X 1/4 Pozidriv pan hd. (Grade 2 steel)
1203	SCREW, No. 8-32 X 7/8 Pozidriv fillister hd. (Grade 2 steel)	2589	SCREW, No. 6-32 X 1/4 Phillips pan hd. (Grade 2 steel)
1309A	SCREW, No. 10-32 X 1/2 Phillips Truss hd. (self-sealing)	2592	SCREW, No. 10-24 X 1/2 Pozidriv pan hd. (Grade 2 steel)
1357W	SCREW, 1/4-20 X 1 Phillips oval ctsk. hd. (stainless)	2594A	SCREW, No. 8-32 X 1/4 Pozidriv pan hd. (w/lockwasher)(Grade 2 steel)
1601	SCREW, No. 8-32 X 1/2 Pozidriv flat ctsk. hd. (Grade 2 steel)	2599	SCREW, 1/4-20 X 1-3/4 Pozidriv pan hd. (Grade 2 steel)
1610	SCREW, 5/16-24 X 1-1/2 Pozidriv flat ctsk. hd. (Grade 2 steel)	2604	SCREW, No. 8-32 X 1/2 Pozidriv pan hd. (Grade 2 steel)
1611	SCREW, No. 10-32 X 3/4 Pozidriv flat ctsk. hd. (Grade 2 steel)	2607	SCREW, 1/4-20 X 3/4 Pozidriv pan hd. (Grade 2 steel)
1614	BOLT, 1/2-20 X 1-1/2 hex. hd. (chrome)		
1643	SCREW, 7/16-14 X 1-1/4 flat socket ctsk. hd. (w/lockpatch)		
1719W	SCREW, No. 8-32 X 5/8 Phillips truss hd.		
1783	SCREW, 5/16-18 X 7/8 Pozidriv flat ctsk. hd. (Grade 2 steel)		
2003	SCREW, 5/16-18 X 1 Pozidriv pan hd. (Grade 2 steel)		
2005	SCREW, 3/8-24 X 15/16 Pozidriv oval ctsk. hd. (Grade 2 steel)(chrome)		

## HARDWARE LISTING

2611B	BOLT, No. 10-32 X 3/4 hex. washer hd. (Grade 5 steel)	2779	SCREW, No. 6-32 X 15/16 pan hd. (self-tapping)
2614	BOLT, 1/4-28 X 2 hex. hd. (Grade 5 steel)	2784	SCREW, 5/16-18 X 7/8 Pozidriv truss hd. (Grade 2 steel)
2623W	SCREW, No. 8-15 X 5/8 pan hd. (self-tapping)(Grade 1 steel)	2790	BOLT, 5/16-18 X 7/8 hex. hd. (w/lockpatch)(Grade 5 steel)
2625	SCREW, No. 8-32 X 5/8 Pozidriv pan hd. (Grade 2 steel)	2796W	SCREW, 1/4-20 X 1-1/2 hex. slot hd. (w/lockpatch)
2630W	SCREW, No. 8-32 X 5/16 rd. hd. (self-tapping)	2804W	SCREW, No. 6-32 X 1/2 Pozidriv pan hd.
2646	SCREW, No. 8-32 X 3/4 Pozidriv pan hd. (Grade 2 steel)	2806	SCREW, No. 6-32 X 3/4 Pozidriv pan hd. (Grade 2 steel)
2647	SCREW, No. 10-24 X 3/4 socket hd.	2818	BOLT, 5/16-18 X 1-1/2 hex. hd. (Grade 5 steel)
2648	SCREW, 1/4-20 X 1 Pozidriv truss hd. (Grade 2 steel)	2823	SCREW, 5/16-24 X 3/8 Pozidriv truss hd. (w/lockwasher)(Grade 2 steel)
2652	SCREW, No. 10-16 X 3/8 hex. washer hd. (self-tapping)	2824W	SCREW, 5/16-24 X 9/16 Phillips hd.
2661W	SCREW, No. 10-24 X 1/2 Phillips rd. hd. (self-tapping)	2831	SCREW, No. 6-32 X 3/8 Pozidriv truss hd. (Grade 2 steel)
2662W	SCREW, No. 10-24 X 3/8 Phillips rd. hd. (self-tapping)	2841W	SCREW, 1/4-28 X 1-7/32 Phillips hd.
2664	SCREW, No. 10-24 X 7/16 Pozidriv pan hd. (Grade 2 steel)	2851	BOLT, 3/8-16 X 7/8 hex. hd. (Grade 5 steel)
2665	SCREW, No. 10-24 X 5/8 Pozidriv pan hd. (Grade 2 steel)	2871W	BOLT, 5/16-18 X 1-1/4 hex. hd. (Grade 5 steel)
2667	BOLT, 5/16-18 X 2 hex. hd. (Grade 5 steel)	2872W	BOLT, 1/4-20 X 1-1/2 hex. hd. (Grade 5 steel)
2682	SCREW, No. 10-32 X 3/8 Phillips truss hd. (stainless steel)	2879W	BOLT, 3/8-16 X 1 hex. hd. (Grade 5 steel)
2692W	SCREW, No. 10-24 X 1/2 socket fillis. hd.	2881W	BOLT, 1/4-20 X 2 hex. hd. (Grade 5 steel)
2698	SCREW, 5/16-18 X 9/16 socket fillis. hd.	2882W	BOLT, 5/16-18 X 5/8 hex. hd. (Grade 5 steel)
2708	SCREW, 5/16-18 X 1 socket hd.	2887W	BOLT, 5/16-18 X 1-3/4 hex. hd. (Grade 5 steel)
2710C	SCREW, No. 4-40 X 3/8 Phillips oval ctsk. hd. (chrome)	2888	SCREW, No. 8-32 X 1/2 Pozidriv truss hd. (Grade 2 steel)
2711	SCREW, No. 4-40 X 3/8 pan hd. (self-tapping)	2889	BOLT, 3/8-24 X 3/4 hex. hd. (Grade 5 steel)
2712	SCREW, No. 10-24 X 9/16 Torx drive (w/lockpatch)	2896	SCREW, 3/8-16 X 7/8 button hd. (self-locking)
2718	BOLT, 1/4-20 X 1-5/8 hex. hd. (Grade 5 steel)	2904	SCREW, 3/8-24 X 3/4 socket hd.
2720	SCREW, no. 10-24 X 1 Torx hd. (w/locking adhesive)	2906	BOLT, 3/8-16 X 7/8 hex. hd (w/lockpatch)(Grade 5 steel)
2726	SCREW, No. 12-24 X 21/32 Phillips truss hd. (chrome)	2907	SCREW, M3 X .05 X 8mm cross recess pan hd.
2731W	SCREW, No. 10 X 3/8 Phillips truss hd. (self-tapping)	2908	SCREW, M3 X .05 X 12mm cross recess pan hd.
2733	SCREW, 1/4-28 X 1/2 slotted rd. hd. (w/lockwasher)(chrome)	2909	SCREW, M3 X .05 X 25mm cross recess pan hd.
2737	SCREW, No. 4-40 X 1/4 Pozidriv pan hd. (Grade 2 steel)	2910	SCREW, M3 X 1.058 X 8mm cross recess pan hd.
2757W	SCREW, 1/4-28 X 7/16 Phillips truss hd. (w/lockwasher)(chrome)	3210	SCREW, 5/16-18 X 1-1/4 socket fillister hd.
2773	SCREW, 1/4-20 X 1/2 Pozidriv pan hd. (Grade 2 steel)	3233	SET SCREW, 1/4-28 X 1/4 socket hd.
2774	SCREW, 1/4-20 X 5/8 Pozidriv pan hd. (Grade 2 steel)	3234W	SET SCREW, 1/4-20 X 5/16 slot hd.
		3403	LOCKNUT, M8 X 7 X 12mm hex.



## HARDWARE LISTING

3409	BOLT, 5/16-24 X 3-1/2 hex. hd. (Grade 5 steel)	3528	BOLT, 3/8-16 X 3-1/4 hex hd. (Grade 8 steel)
3415	BOLT, 5/16 -24X 1 hex. hd. (w/lockpatch)(Grade 5 steel)	3529	SCREW, No. 10-32 X 1/4 slot hex washer hd. (self-tapping)
3419	BOLT, 5/16-18 X 2-1/4 hex. hd. (Grade 5 steel)	3535	BOLT, 1/2-20 X 2 hex. hd.(chrome)
3427	BOLT, 5/16-18 X 3-1/2 hex. hd. (Grade 5 steel)	3536	BOLT, 3/8-16 X 1-1/4 hex hd. (Grade 8 steel)
3429	BOLT, 1/4-20 X 2-3/4 hex. hd. (Grade 5 steel)	3537	SCREW, 1/4-28 X 1/2. flange lock
3430	BOLT, 5/16-24 X 5 hex. hd. (Grade 5 steel)	3538	SCREW, 5/16-24 X 1/2 hex. socket button hd.
3440	BOLT, 3/8-16 X 1/2 hex. hd. (Grade 5 steel)	3540	SCREW, 5/16-18 X 5/8 hex. soc. button hd.
3441	SCREW, 1/4-20 X 3/4 socket fillis. hd. (w/lockpatch)	3545	BOLT, No. 10-24 X 13/16 hex. washer hd.(Grade 18-8 stainless steel)
3444	SCREW, 1/4-20 X 5/8 socket fillis. hd. (w/lockpatch)	3567	SCREW, 5/16-24 X 1 socket fillis. hd.
3445	BOLT, 5/16-18 X 9/16 hex. hd. (w/lockpatch)(Grade 5 steel)	3581	BOLT, No. 10-24 X 3/8 hex. hd.(Grade 2 steel)
3450	BOLT, 1/2-13 X 2-1/2 hex. hd. (Grade 5 steel)	3589	SCREW, 5/16-24 X 1-1/4 socket hd. (chrome)
3461	BOLT, 3/8-16 X 1-5/8 hex. hd. (Grade 8 steel)	3651	SCREW, 1/4-20 X 1/4 socket rd. hd.
3462	BOLT, 5/16-18 X 1-1/4 hex. hd. (Grade 8 steel)	3652	SCREW, 1/4-20 X 3/8 socket hd.(chrome)
3471	BOLT, 1/2-13 X 2-3/4 (Grade 5 steel)	3653	SCREW, 1/4-20 X 19/32 socket pan hd.(chrome)
3473	BOLT, No. 10-32 X 1/2 hex. washer hd. Grade 2 steel)	3655	SCREW, 5/16-18 X 7/8 pan hd.
3479	SCREW, 1/4-20 X 2-1/4 knurled socket hd.	3660	SCREW, 5/16-18 X 3/4 Torx drive pan hd. (w/lockpatch)(SAE J429 Grade B steel)
3481	SCREW, 1/4-20 X 1-1/2 knurled socket hd.	3738	BOLT, 1/4-28 X 1/2 hex. hd. (Grade 5 steel)
3485	SCREW, 5/16-18 X 1-3/4 socket hd.	3765	BOLT, 1/4-28 X 5/8 hex. hd. (Grade 5 steel)
3486	BOLT, 1/2-20 X 1-1/4 hex. hd.	3766	SCREW, No. 10-16 X 15/16 Phillips pan hd. (self-tapping)(black)
3487	BOLT, 5/16-24 X 5/8 hex. locking hd.	3767B	BOLT, 1/4-20 X 5/8 hex. hd. (Grade 5 steel)
3494	BOLT, 5/16-18 X 7/8 hex. hd.	3770	SCREW, 1/4-20 X 7/8 12 pt. hd. (Grade 5 steel)
3500	BOLT, 5/16-18 X 2-3/4 hex. hd. (Grade 8 steel)	3784	SET SCREW, 1/2-20 X 1/2 socket hd. (w/lockpatch)
3501	BOLT, 5/16-18 X 2-1/2 hex. hd. (Grade 8 steel)	3785	BOLT, 3/8-24 X 3/4 hex. hd. (w/lockpatch)(Grade 5 steel)
3503	BOLT, 5/16-24 X 2 hex. hd. (Grade 8 steel)	3787	BOLT, 1/4-20 X 3/4 hex. hd. (Grade 5 steel)
3504	BOLT, 5/16-24 X 5-3/8 hex. hd. (Grade 5 steel)	3802W	BOLT, 1/4-20 X 7/8 hex. hd. (Grade 5 steel)
3506	STUD, 5/16-24 X 5-3/4 hex. hd. (Grade 5 steel)	3825	BOLT, 1/4-28 X 1 hex. hd. (Grade 5 steel)
3509	BOLT, 3/8-16 X 2-3/4 hex. hd. (Grade 8 steel)	3826	BOLT, 1/4-28 X 1-1/4 hex. hd. (Grade 5 steel)
3512	BOLT, 3/8-24 X 3-1/4 hex. hd. (chrome)	3945	BOLT, 3/8-24 X 2-1/4 hex. hd. (Grade 5 steel)
3513	BOLT, 3/8-24 X 3-1/2 hex. hd.	3946	BOLT, 7/16-20 X 2 hex. hd. (Grade 5 steel)
3517	BOLT, No. 10-32 X 1/2 hex. washer hd. (black)	3950	BOLT, 1/2-20 X 4 hex. hd. (Grade 5 steel)
3523	SCREW, No. 6-32 X 5/8 Pozidriv pan hd.	3953W	BOLT, 5/16-24 X 1/2 hex. hd. (Grade 5 steel)
3524	SCREW, No. 6-32 X 3/4 Pozidriv pan hd.		

## HARDWARE LISTING

3958	BOLT, 1/2-20 X 2-1/4 hex. hd.(Grade 5 steel)	4095	SCREW, 5/16-24 X 7/16 socket hd. (w/lockpatch)
3960W	BOLT, 5/16-24 X 1 hex. hd.(Grade 5 steel)	4100HW	BOLT, 5/16-18 X 4 hex. hd.(Grade 5 steel)
3973	BOLT, 1/2-20 X 1-1/4 hex. hd. (drilled)(Grade 5 steel)	4319	BOLT, 3/8-24 X 1 hex. hd. (Grade 5 steel)
3974HW	BOLT, 5/16-24 X 3/4 hex. hd.(Grade 5 steel)	4325	BOLT, 1/4-20 X 5-1/2 hex hd.(Grade 8 steel)
3987	BOLT, 5/16-18 X 3/4 hex. hd.(Grade 5 steel)	4326	SCREW, 5/16-18 X 2 hex. soc. hd.
3991	BOLT, 5/16-18 X 7/8 hex. hd.(Grade 5 steel)	4337W	BOLT, 3/8-24 X 1-1/4 hex. hd.(Grade 5 steel)
3993	BOLT, 1/4-20 X 1-1/4 hex. hd.(Grade 5 steel)	4340	SCREW, 5/16-18 X 4-1/4 socket fillis. hd.
3996	BOLT, 5/8-24 X 7/8 hex. hd.(Grade 5 steel)	4350	SCREW, 3/8-16 X 1-1/2 hex. soc. hd.
3997	BOLT, 1/4-20 X 1-1/4 hex. hd.	4371W	SCREW, 3/8-16 X 1-5/8 socket fillis. hd.
4011	SCREW, 5/16-18 X 1-1/4 socket pan hd.(Grade 5 steel)(black)	4391	BOLT, 5/16-24 X 5/8 hex. hd.(Grade 5 steel)
4013	SCREW, 3/8-16 X 7/8 socket pan hd.(Grade 5 steel)	4401W	BOLT, 3/8-24 X 2-3/4 hex. hd.(Grade 5 steel)
4014W	BOLT, 5/16-24 X 1-1/4 hex. hd.(Grade 5 steel)	4411	BOLT, 3/8-24 X 1-3/4 hex. hd.(Grade 5 steel)
4015	SCREW, 1/4-20 X 7/8 socket rd. hd.(black)	4412	BOLT, 3/8-24 X 2-1/2 hex. hd.(Grade 5 steel)
4016	SCREW, 5/16-18 X 7/8 socket rd. hd.	4416	BOLT, 3/8-24 X 1 hex. hd.(Grade 5 steel)
4017	BOLT, 5/16-18 X 1 hex. hd.(Grade 5 steel)	4435W	BOLT, 3/8-24 X 3-1/2 hex. hd.(Grade 5 steel)
4020W	BOLT, 5/16-24 X 1-3/8 hex. hd.(Grade 5 steel)	4453	BOLT, 1/4-20 X 7/8 hex. hd.
4028	BOLT, 3/4-16 X 2-1/2 hex.hd.	4460	BOLT, 5/8-18 X 1 hex. hd.(Grade 5 steel)
4029	SCREW, 3/8-16 X 2-1/4 socket hd.(black)	4701	BOLT, 5/16-24 X 1-1/2 hex. hd.(Grade 5 steel)
4030	SCREW, 3/8-16 X 2-7/16 socket pan hd.	4713W	BOLT, 3/8-16 X 3/4 hex. hd.(Grade 5 steel)
4033	SCREW, 1/4-20 X 1-5/8 hex. soc. button hd.	4716W	BOLT, 3/8-16 X 1-1/4 hex. hd.(Grade 5 steel)
4036	BOLT, 5/16-24 X 1-1/2 hex. hd.(Grade 5 steel)	4717	SCREW, 1/4-20 X 2-1/4 knurled socket hd.(w/lockpatch)
4053W	BOLT, 5/16-24 X 2 hex. hd.(Grade 5 steel)	4718	SCREW, 1/4-20 X 1-1/2 knurled socket hd.(w/lockpatch)
4061	BOLT, 5/16-18 X 5 hex. hd.(Grade 5 steel)	4720W	BOLT, 3/8-16 X 1-3/4 hex. hd.(Grade 5 steel)
4067	BOLT, 5/16-18 X 4-1/2 hex. hd.(Grade 5 steel)	4721	BOLT, 3/8-16 X 1-1/2 hex. hd.(Grade 5 steel)
4068	BOLT, 5/16-18 X 2-1/2 hex. hd.(Grade 5 steel)	4722	BOLT, 3/8-16 X 2-1/4 hex. hd.(Grade 5 steel)
4069	SCREW, 1/4-20 X 3/4 knurled socket hd.	4724	BOLT, 3/8-24 X 1-1/2 hex. hd.(Grade 5 steel)
4070	SCREW, 5/16-24 X 2-1/4 socket hd.(chrome)	4726	BOLT, 7/16-20 X 1-1/2 hex. hd.(Grade 5 steel)
4079	BOLT, 1/2-13 X 2 hex. hd.(Grade 8 steel)	4729	BOLT, 7/16-20 X 1-1/4 hex. hd.(Grade 5 steel)
4081	BOLT, 1/2-20 X 1-3/4 hex. hd. (Grade 5 steel)	4740	SCREW, 1/4-20 X 1-1/4 knurled socket hd.(w/lockpatch)
4086	BOLT, 1/2-13 X 3 hex. hd.(Grade 5 steel)	4741	SCREW, 1/4-20 X 1 hex. socket hd.(w/lockpatch)
4091	BOLT, No. 10-24 X 1/2 hex. washer hd.(self-tapping)	4800	SCREW, 1/4-20 X 1-1/8 socket pan hd.(w/lockpatch)(Grade 8 steel)
4094	SCREW, No. 10-32 X 1 Pozidriv pan hd.(Grade 2 steel)	4809	SCREW, 5/16-18 X 1-3/8 socket hd.(black)

## HARDWARE LISTING

4810	SCREW, 1/4-20 X 1-3/4 knurled socket hd.(w/lockpatch)	6317	WASHER, 3/4 X 1-1/2 X 1/32(nylon)
4812	SCREW, 1/4-20 X 3/4 knurled socket hd.(w/lockpatch)	6324W	WASHER, 5/16 X 11/16 X 1/16
4813	SCREW, 1/4-20 X 1-3/8 knurled socket hd.(w/lockpatch)	6332B	WASHER, 5/16 X 15/16 X 3/64
4814	SCREW, 1/4-20 X 1-1/8 knurled socket hd.(w/lockpatch)	6333	WASHER, 5/16 X 7/8 X 5/64
4816	SCREW, 5/16-18 X 1-1/2 socket hd.	6334	WASHER, 7/16 X 29/32 X 1/16
4820	SCREW, 1/4-20 X 2 hex. socket	6335	WASHER, No. 4 X 5/16 X 1/32
4825	SCREW, 1/4-20 X 1-3/4 socket pan hd.(w/lockpatch)(Grade 8 steel)	6336B	WASHER, 5/16 X 15/16 X 3 16
4961	BOLT, 3/4-16 X 1-5/8 hex. hd.(Grade 5 steel)	6340	WASHER, 13/16 X 1-15/32 X 1/8
5209	SCREW, No. 12-16 X 5/8 Pozidriv pan hd.	6341B	WASHER, 5/16 X 1-1/8 X 3/64
5403B	CARRIAGE BOLT, 1/4-20 X 3/8	6365	WASHER, 17/32 X 1-1/8 X 5/64
5411	SCREW, 5/16-18 X 7/8 socket rd. hd.(square neck)(Grade 5 steel)	6375B	WASHER, 3/8 X 9/16 X 1/32
5444	CARRIAGE BOLT, 3/8-16 X 1(Grade 5 steel)	6379W	WASHER, 3/8 X 5/8 X 3/64
5465	CARRIAGE BOLT, No. 10-24 X 1/2	6398	WASHER, 3/8 X 13/16 X 3/32(rubber)
6002	WASHER, 5/16 X 5/8 X 1/16(black)	6400HB	WASHER, 5/16 X 13/16 X 3/32
6003	WASHER, 1-3/16 X 1-3/8 X 5/64	6410	WASHER, 1/4 X 9/16 X 1/16(nylon)
6007	WASHER, 5/8 X 5/16 X 3/32(nylon)	6416	WASHER, 3/8 X 1 X 5/64
6012	WASHER, 1/2 X 1-3/16 X 1/16	6448HB	13/32 X 13/16 X 3/32
6016	WASHER, 11/32 X 11/16 X 1/16	6474	WASHER, 3/8 X 13/16 X 5/32
6019	WASHER, 3/8 X 29/32 X 1/16	6497HW	WASHER, 7/16 X 1-1/8 X 3/64
6029	WASHER, 5/32 X 3/8 X 1/32	6506	WASHER, 1-13/32 X 2-3/32 X 1/16 (bronze)
6036	WASHER, 17/64 X 1 X 1/16	6516HW	WASHER, 15/16 X 1-1/8 X 1/8
6047	WASHER, 5/8 X 13/64 X 3/64	6530	WASHER, 1/2 X 1 X 3/16
6048W	WASHER, 1/8 X 1/4 X 1/32	6590HW	WASHER, 1/2 X 1-1/8 X 3/32
6053	WASHER, 3/16 X 7/16 X 1/16(nylon) (black)	6645	WASHER, 11/32 X 1-1/32 X 1/8
6054	WASHER, 3/16 X 9/16 X 1/16	6653	WASHER, 5/8 X 1-5/16 X 3/32
6055	WASHER, 25/64 X 47/64 X 1/8(spring)	6655	WASHER, 5/8 X 1-1/2 X 3/32
6099	WASHER, 1/4 X 7/16 X 1/16	6700B	WASHER, 5/8 X 13/16 X 1/32
6107B	WASHER, 5/16 X 11/16 X 1/8	6701	WASHER, 3/8 X 13/16 X 1/16
6109	WASHER, 5/16 X 11/16 X 1/8	6702	WASHER, 5/16 X 11/16 X 1/16
6113	WASHER, 1/2 X 13/16 X 1/32	6703	WASHER, 1/4 X 5/8 X 1/16
6114	WASHER, 9/32 X 5/8 X 1/32	6712B	WASHER, 5/8 X 15/16 X 3/32
6115	WASHER, 13/32 X 23/32 X 1/16	6716	WASHER, No. 10 X 1/2 X 3/64
6127	WASHER, 13/32 X 13/16 X 5/64	6717	WASHER, No. 6 X 3/8 X 3/64
6150W	WASHER, 3/16 X 3/8 X 1/16	6718	WASHER, 1/2 X 1-1/16 X 3/32
6182W	WASHER, 3/16 X 7/16 X 1/32	6723	WASHER, 17/32 X 1-1/2 X 9/64
6192	WASHER, No. 8 X 7/16 X 3/64	6724	WASHER, 21/32 X 1-1/16 X 1/16
6220W	WASHER, 1/4 X 7/16 X 1/32	6734	WASHER, 19/64 X 41/64 X 5/64(black)
6228W	WASHER, 1/4 X 1/2 X 3/64	6736	WASHER, 9/32 X 5/8 X 1/16
6229W	WASHER, 5/16 X 1-1/16 X 3/64	6737	WASHER, 57/64 X 1-3/64 X 1/32
6235	WASHER, 1/4 X 23/32 X 1/16	6738	WASHER, 17/32 X 7/8 X 7/64
6237	WASHER, 5/16 X 1-1/8 X 5/64	6758	WASHER, 3/8 X 37/64 X 7/64
6242W	WASHER, 1/4 X 9/16 X 1/32	6759	WASHER, 3/16 X 3/8 X 1/32(nylon)
6253W	WASHER, 1/4 X 3/4 X 3/64	6762B	WASHER, 11/16 X 29/32 X 1/32
6261	WASHER, 1/4 X 3/4 X 3/32(rubber)	6771	WASHER, 21/64 X 33/64 X 1/16
6314W	WASHER, 21/64 X 9/16 X 1/8	6774	WASHER, 3/8 X 5/8 X 3/64
6316HW	WASHER, 5/16 X 5/8 X 1/16	6969	LOCKWASHER, No. 4
		7005	LOCKWASHER, 15/64(black)
		7010	LOCKWASHER, No. 6
		7015	LOCKWASHER, No. 8
		7017	WASHER, 17/64 X 33/64 X 5/64(black)
		7018	WASHER, 17/64 X 37/64 X 5/64(black)
		7022	LOCKWASHER, 5/8
		7030W	LOCKWASHER, No. 12
		7036	LOCKWASHER, 1/4
		7038	LOCKWASHER, 3/8

## HARDWARE LISTING

7039	LOCKWASHER, 7/16	7653	ACORN NUT, No. 12-24 X 7/16 X 3/8 hex.(black)
7041	LOCKWASHER, 5/16	7654W	NUT, No. 12-24 X 5/32 X 7/16 hex.
7042	LOCKWASHER, 5/16(high collar)	7667	NUT, 3/8-16 X 9/32 X 9/16 hex. (w/nylon insert)
7043	LOCKWASHER, 3/4	7676	NUT, 1/4-28 X 7/32 X 7/16 hex.(Grade 2 steel)
7045	LOCKWASHER, 3/8(high collar)	7680W	ACORN NUT, 3/8-16 X 25/32 X 9/16 hex. (Grade 2 steel)(chrome)
7068	LOCKWASHER, 1/2	7682	LOCKNUT, 1/4-28 X 3/16 X 7/16 hex.
7069	LOCKWASHER, No. 10	7683	LOCKNUT, 1/4-28 X 5/16 X 7/16 hex.
7112	LOCKWASHER, No. 6 internal tooth	7686	LOCKNUT, 1/4-20 X 5/16 X 7/16 hex.
7115	LOCKWASHER, No. 8 internal tooth	7688	NUT, 1/4-20 X 7/32 X 7/16 hex.(Grade 2 steel)
7118	LOCKWASHER, No. 10 internal tooth	7689W	JAM NUT, 1/4-20 X 5/32 X 7/16 hex. (Grade 2 steel)
7124	LOCKWASHER, 1/4 internal tooth	7715	LOCKNUT, 5/16-18 X 17/64 X 1/2 hex.
7127	LOCKWASHER, 5/16 internal tooth	7725	LOCKNUT, 5/16-24 X 11/32 X 1/2 hex.
7129	LOCKWASHER, 1/2 internal tooth	7727	LOCKNUT, 5/16-24 X 1/4 X 1/2 hex.
7130W	LOCKWASHER, 3/8 internal tooth	7729	LOCKNUT, 5/16-24 X 1/4 X 1/2 hex.
7142	LOCKWASHER, 3/4 internal tooth	7734W	CASTLE NUT, 1/2-20 X 9/16 X 3/4 hex. (Grade 5 steel)
7145W	LOCKWASHER, 3/8 external tooth	7736	ACORN NUT, 5/16-24 X 19/32 X 1/2 hex. (Grade 2 steel)(chrome)
7220	LOCKWASHER, No. 10 external tooth	7737W	ACORN NUT, 1/4-20 X 15/32 X 7/16 hex. (Grade 2 steel)
7229W	LOCKWASHER, 1/4 internal/external tooth	7739	LOCKNUT, 5/16-18 X 11/32 X 1/2 hex.
7230	LOCKWASHER, 1/4 external tooth	7740	LOCKNUT, 5/16-18 X 1/4 X 1/2 hex.
7232	LOCKWASHER, 5/16 external tooth	7741	LOCKNUT, 1/2-20 X 1/2 X 3/4 hex.
7415A	WASHER, 11/32 X 7/8 X 1/8(rubber)	7742	LOCKNUT, 1/4-20 X 7/32 X 7/16 hex.
7419	WASHER, 11/32 X 11/16 X 1/8(rubber)	7743	SPEED NUT, for 1/4-20 bolt
7501	SPEED NUT, 1/4 dia. stud size(self threading)	7744	JAM NUT, 5/16-24 X 3/16 X 1/2 hex. (Grade 2 steel)
7506	NUT, No. 4-48 X 3/32 X 1/4 hex.(Grade 2 steel)	7748W	NUT, 5/16-18 X 1/4 X 1/2 hex.(Grade 2 steel)
7507	ACORN NUT, 5/16-18 X 11/16 X 1/2 hex.(Grade 2 steel)(chrome)	7752	SPEED NUT, for 5/16-18 screw
7510	CLIP NUT, 1/4-28	7753	NUT, 5/16-24 X 1/4 X 1/2 hex.(Grade 2 steel)
7513	ACORN NUT, 5/16-24 X 19/32 X 1/2 hex.	7768W	LOCKNUT, 1/2-13 X 19/32 X 3/4 hex.
7515	JAM NUT, 7/16 X 1/4 X 11/16(Grade 2 steel)	7775	LOCKNUT, 3/8-24 X 7/16 X 9/16 hex.
7520	ACORN NUT, No. 6-32 X 1/4 X 1/4 hex.(nylon)	7776W	LOCKNUT, 3/8-24 X 9/32 X 9/16 hex.
7531	LOCKNUT, 5/16-18 X 9/32 X 1/2 hex.	7778	LOCKNUT, 3/8-16 X 7/16 X 9/16 hex.
7561	NUT, 7/16-20 X 7/16 X 11/16 hex.	7780	LOCKNUT, 3/8-24 X 13/32 X 11/16 hex.
7590	NUT, No. 6-32 X 1/8 X 5/16 hex.(Grade 2 steel)	7782	LOCKNUT, 3/8-24 X 3/8 X 9/16 hex. (Grade 8 steel)
7602	ACORN NUT, No. 10-32 X 5/16 X 23/64 hex.(nylon-locking)	7783	NUT, 3/8-16 X 5/16 X 9/16 hex.(Grade 2 steel)
7606	LOCKNUT, No. 8-32 X 1/4 X 1/4 hex.(chrome)	7800W	NUT, 3/8-24 X 5/16 X 9/16 hex.(Grade 2 steel)
7608	NUT, No. 8-32 X 1/8 X 11/32 hex.(Grade 2 steel)	7812W	LOCKNUT, 1/2-20 X 5/16 X 3/4 hex.
7609W	LOCKNUT, No. 8-32 X 3/16 X 5/16 hex.	7813	NUT, 5/8-18 X 9/16 X 15/16 hex.(Grade 2 steel)
7613A	SPEED NUT, 1/8 dia. stud size	7823	CASTLE NUT, 5/8-18 X 3/8 X 15/16 hex. (Grade 2 steel)
7620W	NUT, No. 10-24 X 1/8 X 3/8 hex.(Grade 2 steel)	7825	LOCKNUT, 7/16-20 X 7/16 X 5/8 hex.
7624	LOCKNUT, No. 10-24 X 1/4 X 3/8 hex.		
7626W	LOCKNUT, No. 10-32 X 3/16 X 3/8 hex.		
7634	NUT, No. 10-32 X 1/8 X 5/16 hex.(brass)		
7635W	NUT, No. 10-32 X 13/32 X 3/8 hex.		
7638	NUT, No. 10-32 X 1/8 X 3/8 hex.(Grade 2 steel)		
7652	NUT, 3/4-16 X 1-1/8 hex.(chrome)		

## HARDWARE LISTING

7837W	NUT, 7/16-20 X 3/8 X 11/16 hex.(Grade 2 steel)	7993	LOCKNUT, 5/8-18 X 15/16 hex.
7844	LOCKNUT, 1/2-13 X 5/16 X 3/4 hex.	8101	SPEED NUT, for 5/16-18 bolt
7845	NUT, 1/2-20 X 7/16 X 3/4 hex.(Grade 2 steel)	8102	SPEED NUT, for 5/16-18 screw
7848W	JAM NUT, 7/16-20 X 1/4 X 11/16 hex.(Grade 2 steel)	8107	SPEED NUT, for No. 10-A or Z thread screws
7855W	JAM NUT, 3/4-16 X 7/16 X 1-1/8 hex.(Grade 2 steel)	8108	SPEED NUT, 11/32 dia.
7880	NUT, 1/2-13 X 7/16 X 3/4 hex.(Grade 2 steel)	8125	SPEED NUT, for 8-32 bolt
7986	NUT, 5/8-18 X 5/8 X 1-1/16 hex.(Grade 5 steel)	8126	SPEED NUT, 3/16 dia. stud size
		8131W	LOCKNUT, No. 4-40 X 1/8 X 1/4 hex.
		8135W	SPEED NUT, 1/4 dia. stud size
		8151	SPEED NUT, for No. 10-32 screw
		8155	SPEED NUT, for No. 8-32 screw

## NUMERICAL INDEX

Part No.	Page	Part No.	Page	Part No.	Page	Part No.	Page	Part No.	Page
255	18	4815	5	9488 RA	4	16563-72R	2	18221-79R	3
350	13	6016	2	9501 RA	4	16571-77R	2	18228-66RA	3
358	5		5	9504 RA	4	16572-77R	2	18241-67R	3
375	5	6218 W	6	9506 RA	4	16602-30	2	18242-67R	3
603	8		10	9507 RA	4	16679-89R	2	18243-67R	3
612	11	6220 W	5	9508 RA	4	16682-88R	2	18245-67R	3
637 R	8	6236 B	5	9946	18	16684-88R	2	18246-67R	3
707	5	6470 R	2	9954	18		2	18247-67R	3
718	5	6486 HW	2	9955	10	16774-72R	1	18508-72RA	3
720	5	6530	2		18		2	18534-29A	3
721	8	6701	5	9956	10	16818-72R	2	18607-74RA	3
744 R	10		14		18	16819-72R	2	22159-86R	3
852	6	6703	5	9964	6	16820-72R	2	22286-86R	3
	10		8		18	16825-48	13	22287-86R	3
858	2		14	9969	18	16830-83R	2	22288-86R	3
1205	17	6716	6	9991 A	18		5	22289-86R	3
1793 R	7		10	10006	17	17390-83	2	22528-86RA	3
	7	6778	6	10048	18	17402-79RB	2	22529-86RA	3
1795	7	7022	16	10058	18	17403-79RB	2	22530-86RA	3
	10	7036	5	10074	18	17404-79RB	2	22531-86RA	3
1797 R	7		8	11036	13	17405-79RB	2	22532-86RA	3
2269 W	5		8		17	17428-72R	2	22720-86RA	3
2613	14		13	11052	5	17435-88R	2	23754-89R	4
2659	10	7038	5	11100	1	17436-74R	2	23755-89R	4
2660	11		14		2	17451-72R	2	23756-89R	4
	16	7041	5	11110	1	17452-72R	2	23757-89R	4
2664	6		13		2	17453-72R	2	23947-87R	4
2851	5	7069	6	11115	1	17454-72R	5	23947-88R	4
	14		10		2	17514-74R	2	23962-87R	4
2879 W	5		11	11159	1	17514-88R	2	23962-88R	4
2881 W	5		16		8	17515-74R	2	23973-87R	4
	8	7220	14	12021	1	17515-88R	2	23977-88R	4
	14	7739	16		11	17910-88R	2	23978-88R	4
2882 W	5	7744	16		14	17916-77R	2	23985-12	14
3206 B	2	7753	13	12023	1	17917-88R	2	24003-41R	14
3231 B	7		16		2	17935-88R	2	24004-88R	7
3429	5	7775	5	12043	1	17951-72R	2	24007-88R	7
	8		16		10	18054-72RA	2	24011-67RA	7
3478	7	7812 WA	10	14166-87R	17	18060-72RA	2	24221-51	5
3482	7	7837 W	2	16212-59R	5	18067-82R	3		7
3494	10	7845	2	16218-52	5	18068-74R	3	24324-88R	4
3720	5	8873	8	16230-59R	5	18071-72R	1	24325-88R	4
3789 A	10		8	16237-57	5		3	24331-36	4
3991	11	8888	11	16243-88R	4	18081-76R	3	24332-36	4
4017	2	8975	11	16244-88R	4	18083-82R	3	24363-55RB	4
4067	5	8995	11	16245-88R	4	18150-84R	3	24365-55RB	4
4068	5	9017	7	16246-88R	4	18152-84R	3	24380-88R	5
4072	5	9028 R	5	16301-81	18	18154-84R	3	24381-88R	4
4086	2		7	16302-81	6	18159-84R	3	24382-88R	4
4100 HW	5	9098 R	5		18	18160-84R	3	24512-88R	5
4392	2	9260	13	16304-87	2	18162-84R	3	24552-88R	5
4410	13	9481 RA	4		6	18164-84R	3	24578-57	11
4413	5	9484 RA	4		18	18169-84R	3	24702-52R	5
4621	13	9486 RA	4	16472-88R	2	18200-79R	3	24702-72R	3
4720	5	9487 RA	4	16474-88R	2	18220-79R	3	24702-86R	3

## NUMERICAL INDEX

Part No.	Page	Part No.	Page	Part No.	Page	Part No.	Page	Part No.	Page
24776-88R	1	26318-54R	8	32457-88R	10	34947-89R	6	35370-72RA	4
	4	26320-72R	8	32458-88R	10	34949-64	6	35374-72RA	4
24777-83R	4	26320-88R	8	32459-88R	10	34952-52	1	35375-72RA	4
	5	26322-52A	8	32460-88R	10		6	35376-72RA	4
24777-88R	4	26322-88R	8	32461-88R	10	35044-72RA	11	35377-72RA	4
	5	26323-52A	8	32462-88R	10	35047-53	11	35409-74R	4
24821-74RA	1	26323-88R	8	32463-88R	8		14		7
	6	26327-52	8		18	35050-52	11	35412-74R	7
24937-88R	6	26327-88R	8	32507-89R	10		14	35413-74R	7
	7	26331-74R	8	32522-37	1	35112-52	11	35414-74R	7
	18	26331-88R	8		7	35150-52	1	35415-74R	7
24975-37	5	26338-68	18	32531-36	18		11	35416-74R	7
24996-74RA	6	26340-36	8	32534-81R	18	35151-52A	1	35417-74R	7
24998-74R	6		8	33080-83R	5		11	35418-74R	7
24999-74R	6	26341-37	8	33450-70R	14	35169-52	1	35605-88R	11
25198-88R	7		8	34011-90R	13		11	35606-88R	11
25200-74R	7	26364-57	8	34035-52	1	35197-52	14	35613-78	11
25224-52A	1	26364-72	8		13	35198-52	14	35613-88R	11
	7	26420-74R	8	34037-52	5	35198-53R	14	35695-58	12
25234-53R	7		8		7	35200-53R	14	35695-58R	12
25507-88R	7	27015-72R	1		13	35201-53R	14	35695-60R	12
	10		10	34040-52	13	35202-53R	14	35709-54B	12
25518-74R	7	27015-88R	10	34062-52	13	35205-52A	14	35750-58A	12
25519-74R	7	27033-72RB	10	34065-52	13	35205-52RA	14	35750-58R	12
25535-74R	1	27033-88R	10	34067-52	13	35205-54R	14	35760-54RA	12
	7	27036-72RB	10	34068-52A	13	35277-52A	11	35760-61R	12
25567-88R	7	27036-88R	10	34069-71	13	35277-54R	11	35760-84A	12
25568-88R	7	27060-88R	10	34070-85R	13	35277-61R	11	35787-72	12
25569-88R	7	29000-86R	10	34071-85R	13	35296-56A	11	35809-58	12
25570-88R	7	29615-39R	7	34072-85R	13	35296-56R	11	35818-72	12
	10	29691-50R	11	34141-52A	13	35305-56A	11	35819-72	12
25571-88R	7	29692-78R	11	34168-52	13	35327-73	12	35820-52	12
25572-88R	7	29693-78R	11	34291-52C	13	35328-73	12	35821-52	12
25592-74R	7	29694-56R	11	34292-72A	13	35329-73	12	35821-72	12
26203-74R	8	29695-88R	11	34293-72A	13	35336-74	13	35824-52	12
26203-88R	8	29696-88R	11	34461-72	13	35337-56	11	35825-52	12
26217-74R	8	29698-56RA	11	34476-72	13	35343-73	11	35828-52	12
26217-88R	8	29699-88R	7	34485-52	13	35344-73	11	35829-52	12
26227-58	1	29700-88R	7	34494-74C	13	35351-52RB	11	35836-55	12
	8	29701-88R	7	34500-52A	13	35352-52RB	11	35838-55	12
	8		10	34506-52A	13	35354-52RB	11	35839-55	12
26228-88R	8	29702-88R	7	34507-52A	13	35355-72RB	11	35840-52	12
26229-88R	8		10	34514-75A	13	35357-82	10	35841-58	12
26241-74R	8	29962-88R	10	34606-52R	13		11	35860-86	12
26250-56	8	29963-88R	10	34609-52	13	35358-82	10	35861-86	12
26250-88R	8	29971-88R	10	34628-52R	13		11	35862-86	12
26256-72R	1	29972-88R	10	34844-57B	6	35359-82	10	35863-86	12
	8	29973-88R	10		11		11	35864-86	12
26258-52	1	31978-88R	10	34872-57A	11	35360-82	10	35865-86	12
	8	31979-88R	10		11		11	35891-66	13
26259-72R	1	32301-88R	10		14	35361-56	11	35960-54	12
	8	32304-88R	10	34890-52	11	35364-56	11	35961-52	10
26316-83R	8	32452-88R	10	34891-52	11	35367-72RA	4		12
26317-72A	8	32453-88R	10		16	35368-72RA	4	37201-54	14
26317-88R	8	32454-88R	10	34946-88R	6	35369-72RA	4	37210-47	14



## NUMERICAL INDEX

Part No.	Page	Part No.	Page	Part No.	Page	Part No.	Page	Part No.	Page
37222-52	14	41456-72R	14	62375-57	18				
37224-90R	13	41457-72R	14	62570-83	8				
37276-53	14	41460-72R	14		18				
37280-85R	14	41461-72R	14	62625-70A	17				
37281-47	14	41472-74R	14	62702-52	6				
37282-53	14	41473-74R	14	62762-52	17				
37449-56	12	41474-74R	14	63500-68	17				
37450-56R	12	41475-74R	14	63501-68	17				
37450-60R	12	41488-72R	14	63513-88R	17				
37450-61R	12	41835-30R	17	63514-88R	6				
37458-52	12	41835-57R	10	63516-88R	6				
37527-67	15	43077-78R	16	63517-88R	6				
37533-52A	15	43078-78R	16	63519-88R	6				
37534-89R	15	43318-78R	16		17				
37631-83R	15	43329-84R	16	63533-41	8				
37632-83R	15	45024-65A	17	63540-62	18				
37722-52	15	45030-65A	17	63541-74R	8				
37731-52	15	45031-65	17		18				
37742-83R	1	45034-68	17	63573-82	17				
	15	45830-48	3	63578-52	18				
37758-83R	15		8	63580-66A	18				
37760-88R	15	47511-52	16	63780-75RA	18				
37761-83R	15	47512-74	16	63780-88R	6				
37762-52	1	47514-74	16		18				
	15	47515-74	16	67142-52	1				
37763-88R	15	47517-74	16		3				
37876-52	15	47518-52	16	83162-51	1				
37985-52A	15	47519-52	16		4				
37992-52	15	47521-74	16	91737-60R	18				
38016-88R	15	47525-52	16	92064-74R	18				
38076-53R	15	47550-74	16	99491-89R	18				
38077-41	15	48302-85	16						
38105-78R	15	48315-60	16						
38130-54	15	48371-70R	16						
38135-50	15	50939-52	16						
38519-57A	17	50939-60R	16						
38619-57A	15	50940-52	16						
38705-65	17	52002-74R	16						
39972-72R	16	52050-70RA	16						
39975-54A	14	52590-77A	6						
39978-58	14		18						
39979-58A	14	53254-74	17						
40002-52R	14	56209-74R	17						
40005-52RA	14	56359-88R	17						
40005-57	14	56360-88R	17						
40008-52RA	14	60567-36	1						
40029-15E	14		6						
40228-52R	14	60570-64	6						
40233-52R	14	60998-70R	17						
40238-52R	14	60999-70R	17						
40238-64R	14	61103-36	17						
41198-73	14	61571-74R	17						
41453-72R	14	61601-79R	17						
41454-72R	14	61603-84R	17						
41455-72R	14	61634-62R	17						