



Harley-Davidson, Inc.

# PARTS CATALOG

## FXR Models

### 1984 to 1986

Part No. 99439-86A

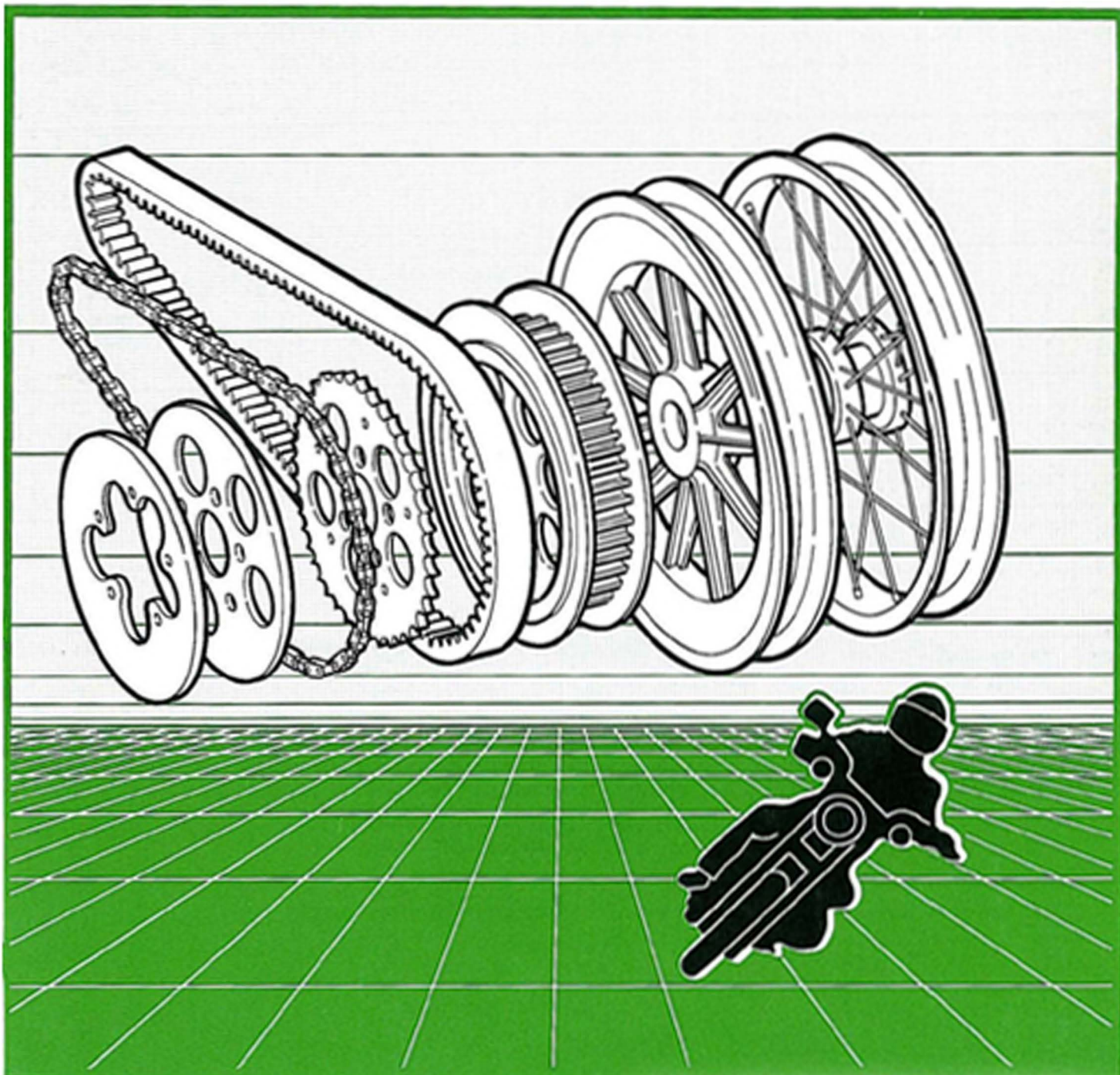

## GENERAL INFORMATION

This Parts Catalog has been prepared for your convenience when ordering parts for the 1984 and later FXR Models. For 1982 and 1983 FXR Models refer to Parts Catalog Part No. 99439-83A. Wherever possible, parts are shown in assembly breakdown sequence. Index numbers shown in the illustrations correspond to index numbers in parts lists. Consult the illustrations when ordering parts so you are sure to get what you want.

Number in parenthesis following description of part is the quantity needed for complete assembly. If there is no number in parenthesis, only one is used.

Prices of parts listed in this catalog are published separately in the latest RETAIL PRICE LIST.

The following instructions should be followed carefully when ordering parts:

- Specify the correct part number for each item. Check the "Used On" column of the parts list which shows the model on which the part fits. Whenever in doubt, refer to the Vehicle Identification Number (V.I.N.) stamped on the engine crankcase. A 17 digit V.I.N. is stamped on the frame steering head and frame downtube label. An abbreviated V.I.N. is stamped on the engine crankcase.
- Always give one of these numbers when ordering parts or making any inquiry about your motorcycle.

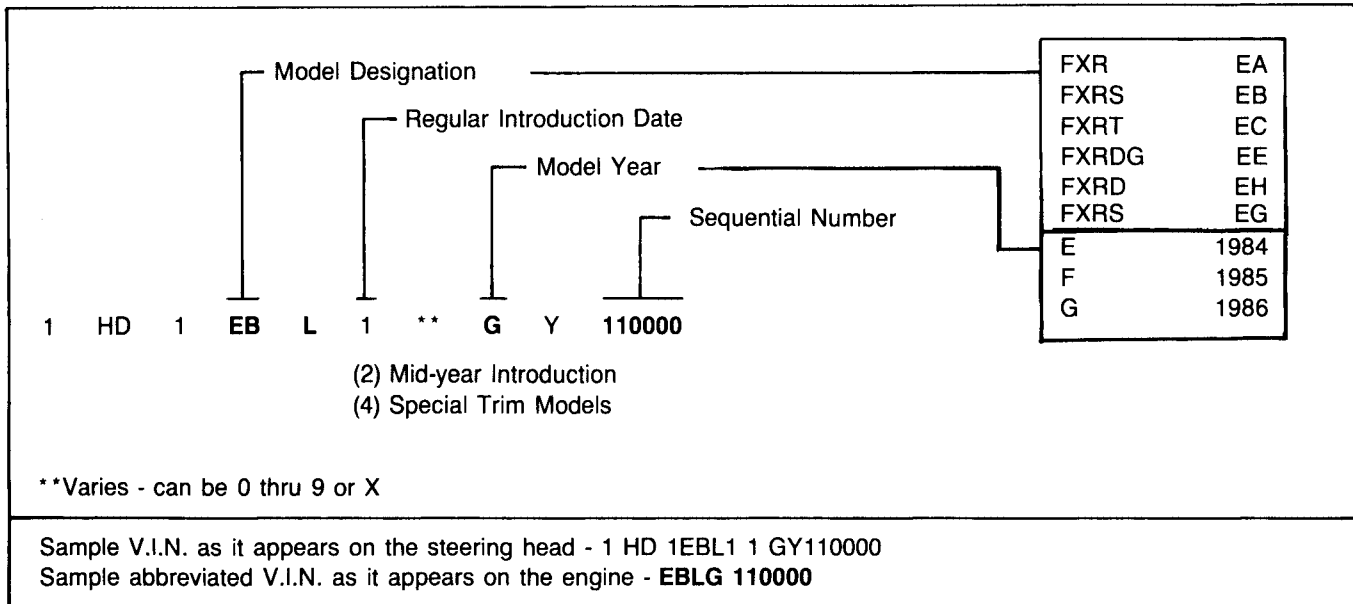

- **An asterisk (\*) in the "Used On" column indicates part is used for the 1986 models (the latest model year covered by this catalog).**
- Part Numbers are to be used when ordering by TELEGRAM or CABLE.
- When ordering parts use our standard Parts & Accessories order form, Part No. 99511-76, for all parts except engines and crankcases. Order form, Part No. 99514-76, must be used for engines and crankcases. The use of these forms will enable us to fill and ship your order more promptly. These forms are furnished free of charge upon request.
- Do not order motorcycles or advertising material on Parts Order Forms. Write nothing on the order form except the order itself, as any other correspondence will not be answered until the order is shipped and billed.
- Freight, Express and Parcel Post orders should be on separate order forms.
- For your own records, number and date all orders, also keep a copy for future reference.

**READERS COMMENTS**

The Harley-Davidson Technical Communications Department maintains a continuous effort to improve the quality and usefulness of its publications. To do this effectively, we need user feedback — your critical evaluation of this manual.

Please comment on this manual's completeness, accuracy, organization, usability, and readability.

\_\_\_\_\_  
\_\_\_\_\_  
\_\_\_\_\_  
\_\_\_\_\_  
\_\_\_\_\_

Should you find errors in this manual, please list the page, item and part number.

\_\_\_\_\_  
\_\_\_\_\_  
\_\_\_\_\_  
\_\_\_\_\_  
\_\_\_\_\_  
\_\_\_\_\_  
\_\_\_\_\_  
\_\_\_\_\_  
\_\_\_\_\_  
\_\_\_\_\_  
\_\_\_\_\_

How can this manual be improved? \_\_\_\_\_

\_\_\_\_\_  
\_\_\_\_\_  
\_\_\_\_\_

Occupation: \_\_\_\_\_

Name \_\_\_\_\_ Dealership \_\_\_\_\_

Street \_\_\_\_\_ Department \_\_\_\_\_

City \_\_\_\_\_ State \_\_\_\_\_ Zip \_\_\_\_\_

CUT HERE

# ALPHABETICAL INDEX

	Page		Page
Air Cleaner .....	19	Indicator Lamps .....	85, 107, 109, 111
Air Control - front fork .....	69	Instruments — FXRS,	
Alternator .....	21	1984 & 1985 FXRT .....	107
Battery .....	131	Instruments — FXR .....	109
Belt — rear .....	47	Instruments — 1986 FXRT, FXRD	111
Belt Guard — FXRS .....	59	Jiffy Stand .....	73
Belt Guard — FXRT, FXRD .....	61	Lamps .....	88, 89, 107, 109, 111, 113, 115
Brake Caliper - front .....	51	License Plate Bracket .....	91
Brake Caliper - rear .....	57	Mirror .....	117
Brake Control - front .....	49	Muffler .....	103, 105
Brake Control - rear .....	55	Numerical Index .....	154
Brake Disc .....	53, 59, 63	Oil Filter .....	35
Breather Valve .....	13	Oil Pressure Switch .....	13, 15
Cam Gears .....	13	Oil Pump .....	15
Carburetor .....	17	Oil Tank .....	101
Chain .....	45, 47	Pistons .....	7
Chain Guard — rear .....	61, 63	Piston Rings .....	7
Choke .....	17, 19	Primary Housing .....	93, 95
Circuit Breaker .....	129	Push Rods .....	5
Clutch — Early 1984 .....	39	Regulator .....	21
Clutch — Late 1984 .....	41	Saddlebags .....	133, 135
Clutch Control .....	43	Seat .....	71
Connecting Rods .....	7	Shifter .....	29, 31
Crankcase .....	11, 13	Shock Absorbers .....	79
Cylinders .....	3	Sissy Bar .....	71
Electrical .....	119, 121	Sound System .....	123
Emissions Kit .....	136	Spark Coil .....	23
Engine .....	3, 5	Spark Plugs .....	23
Exhaust System —		Speedometer .....	107, 109, 111
FXR, FXRS, FXRT .....	103	Sprockets .....	45, 47, 59, 63
Exhaust System — FXRD .....	105	Stabilizer Link — engine .....	11
Fairing .....	83, 85	Starter Motor .....	27
Fenders .....	91	Starter Shaft and Housing .....	25
Flywheels .....	7	Switches .....	55, 125, 127, 129
Footboards — FXRD .....	77	Switches, handlebar .....	127
Footrests, FXR, FXRS, FXRT .....	75	Switches, ignition .....	129
Fork — front — FXR, FXRS .....	65	Switches, starter .....	125
Fork — front — FXRT, FXRD .....	67	Tachometer .....	107, 111
Fork — rear .....	73	Tail Lamp .....	113, 115
Frame .....	73	Tanks .....	97, 101
Fuel Tank .....	97, 99	Tappets .....	5
FXRC — Parts — Late 1985 .....	138, 139	Throttle Control .....	79
FXRC — Parts — Late 1986 .....	152, 153	Timer .....	23
FXRDG — Parts .....	137	Tour-Pak .....	87
FXRS — Parts — Hi-Perf. ....	141-151	Transmission .....	33, 35, 37
Gasket Sets .....	3, 5	Turn Signals .....	83, 113, 115
Gauges .....	97, 107, 109, 111	Vacuum Switch .....	3, 17
Gearcase .....	13	Valves .....	3
Handlebar .....	81	Voltage Regulator .....	21
Headlamp — FXR, FXRS .....	89	Wheel — front .....	53
Headlamp — FXRT, FXRD .....	88	Wheel — rear .....	59, 61, 62, 63
Horn .....	117	Windshield .....	83
Ignition Module .....	23	Wiring .....	119, 121
Ignition Switch .....	129		

## PATENT NOTICE

Harley-Davidson products are manufactured under one or more of the following: U.S. Patents — 2986162, 2987934, 2998809, 3116089, 3144631, 3144860, 3226994, 3229792, 3434887, 3559773, 3673359, 3680403, 3683716, 3709317, Des. 225 626.

To the best knowledge of Harley-Davidson, Inc., the material contained herein is accurate as of the date this publication was approved for printing. Harley-Davidson, Inc., reserves the right to change specifications, equipment, or designs at any time without notice and without incurring obligation.



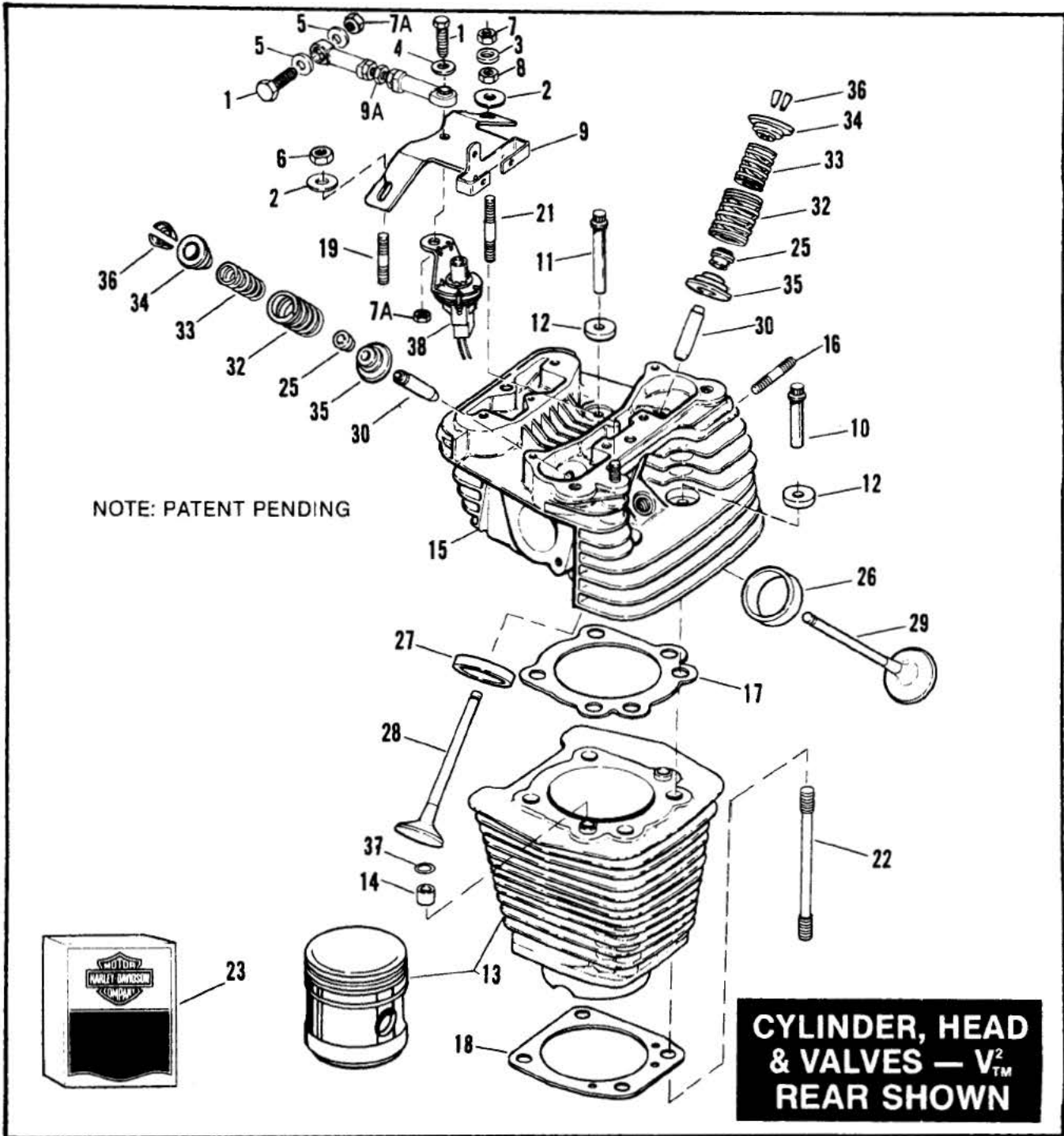

RETAIL PRICE	INDEX NO.	PART NO.	NAME	USED ON
	1	4721	BOLT (2)	84 to * — All Models
	2	6019	WASHER (2)	84 to * — All Models
	3	6379W	WASHER	84 to * — All Models
	4	6400HB	WASHER	84 to * — All Models
	5	6701	WASHER (2)	84 to * — FXRS, FXRT; 86 to * — FXR
	6	7775	LOCKNUT	84 to * — All Models
	7	7776W	LOCKNUT	84 to * — All Models
	7A	7778	LOCKNUT (2)	84 to * — All Models
	8	7800W	NUT	84 to * — All Models
	9	16216—83D	BRACKET, engine mounting	84 to * — All Models
	9A	16219—79A	STABILIZER LINK, top	84 to * — All Models
	10	16478—83	SCREW (4)	84 & Early 85 — FXRS, FXRT
		16478—85A	SCREW, internal thread (4)	Late 85 to * — All Models
	11	16480—83	SCREW (4)	84 & Early 85 — FXRS, FXRT
		16480—85A	SCREW, internal thread (4)	Late 85 to * — All Models
	12	16482—83	WASHER (8)	84 & Early 85 — FXRS, FXRT
		16482—85	WASHER (8)	Late 85 to * — All Models
	13	16510—83	CYLINDER WITH PISTON (2)	84 to * — All Models
	14	16573—83	INSERT, cylinder stud (4)	84 to * — All Models
	15	16690—85A	HEAD, rear cylinder — includes valve guides & seats	84 to * — All Models
		16691—85A	HEAD, front cylinder — includes valve guides & seats	86 to * — All Models
	16	16715—83	STUD, exhaust flange (4)	84 to * — All Models
	17	16773—85	GASKET, cylinder head (2)	84 to * — All Models
	18	16774—86A	GASKET, cylinder base (2)	84 to * — All Models
	19	16830—29A	STUD, engine mounting bracket (short)	84 to * — All Models
	21	16831—83	STUD, engine mounting bracket (long)	84 to * — All Models
	22	16837—83	STUD, cylinder base (8)	84 & Early 85 — FXRS, FXRT
		16837—85A	STUD, cylinder base (8)	Late 85 to * — All Models
	23	17033—83A	GASKET KIT, top overhaul	84 to * — All Models
		17035—83B	GASKET KIT, engine overhaul	84 to * — All Models
	25	18001—83A	SEAL, valve (4)	84 to * — All Models
	26	18010—83	INSERT, exhaust valve seat (2)	84 to * — All Models
	27	18020—83	INSERT, intake valve seat (2)	84 to * — All Models
	28	18074—83A	INTAKE VALVE (2)	84 to * — All Models
		18076—83	INTAKE VALVE — 0.030 short (2)	84 to * — All Models
	29	18082—83	EXHAUST VALVE (2)	84 to * — All Models
		18087—83	EXHAUST VALVE — 0.030 short (2)	84 to * — All Models
	30	18130—83C	VALVE GUIDE, int. & exh. — 0.001 O.S. (4)	84 to * — All Models
		18131—83C	VALVE GUIDE, int. & exh. — 0.003 O.S. (4)	84 to * — All Models
		18133—83A	VALVE GUIDE, int. & exh. — 0.002 O.S. (4)	84 to * — All Models
	32	18201—83	VALVE SPRING, outer (4)	84 to * — All Models
	33	18202—83	VALVE SPRING, inner (4)	84 to * — All Models
	34	18219—83A	COLLAR, valve spring — upper (4)	84 to * — All Models
	35	18222—83	COLLAR, valve spring — lower (4)	84 to * — All Models
	36	18229—83	RETAINER, valve collar (4; 8 — 85 & Later)	84 to * — All Models
	37	26432—76A	O-RING, cylinder stud insert (4)	84 to * — All Models
	38	26557—83	VACUUM SWITCH, carburetor	84 to * — All Models

NOTE: PATENT PENDING

# ROCKER ARMS, COVER & PUSHROD — V<sup>2</sup><sub>TM</sub>

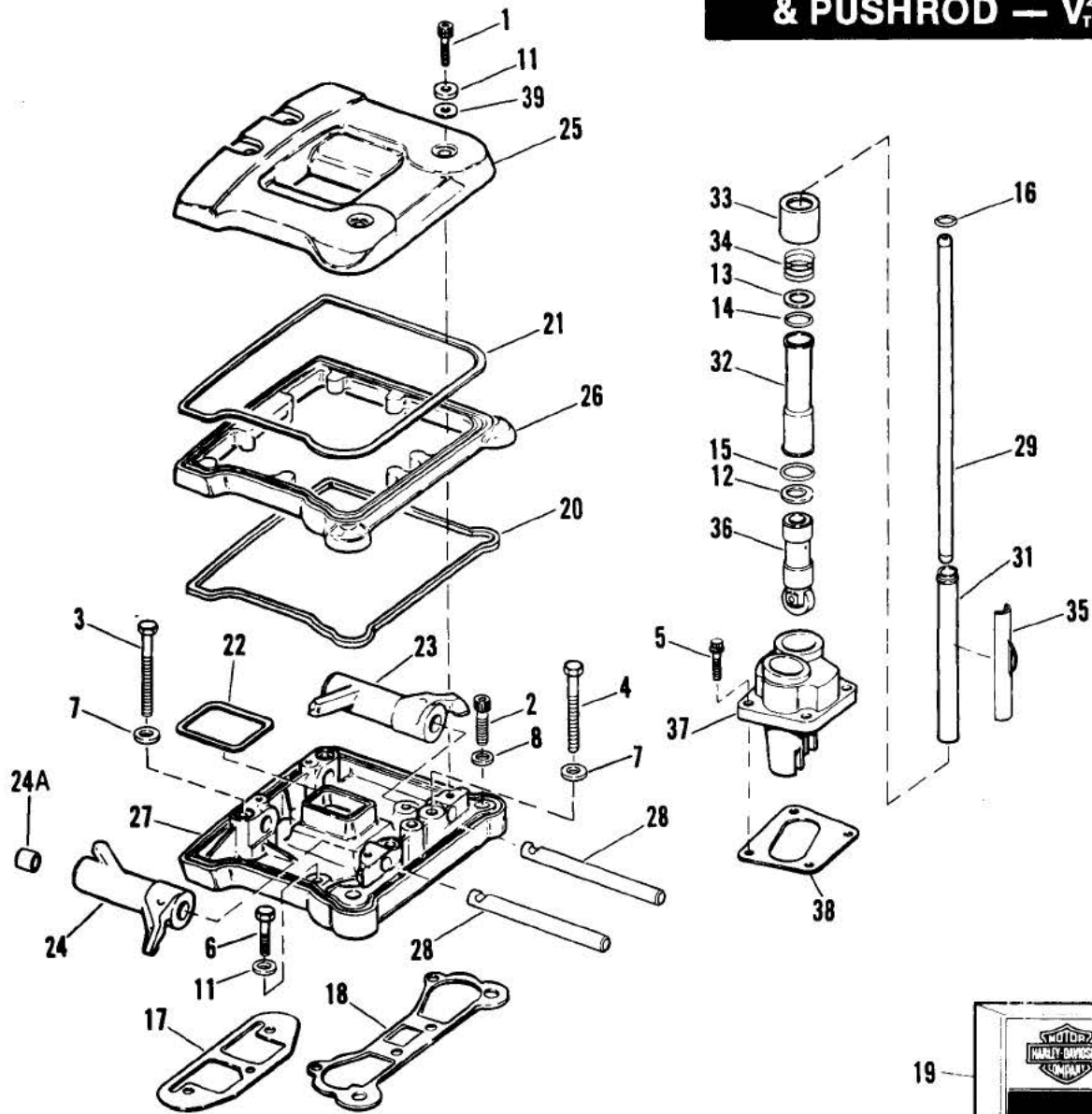

NOTE: PATENT PENDING

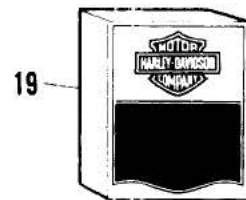

RETAIL PRICE	INDEX NO.	PART NO.	NAME	USED ON
	1	884	SCREW (8)	84 to * — All Models
	2	3481	SCREW (4)	84 to * — All Models
	3	3500	BOLT (4)	84 to * — All Models
	4	3501	BOLT (4)	84 to * — All Models
	5	3770	SCREW (8)	84 to * — All Models
	6	3997	BOLT (6)	84 to * — All Models
	7	6016	WASHER (8)	84 to * — All Models
	8	6099	WASHER (4)	84 to * — All Models
	11	6736	WASHER (14)	84 to * — All Models
	12	6737	WASHER (4)	84 to * — All Models
	13	6762B	WASHER (4)	84 to * — All Models
	14	11132	O-RING, push rod cover — middle (4)	84 to * — All Models
	15	11145	QUAD SEAL, push rod cover — lower (4)	84 to * — All Models
	16	11157	O-RING, push rod cover — upper (4)	84 to * — All Models
	17	16778—84	GASKET, cylinder head — right (2)	84 to * — All Models
	18	16779—84A	GASKET, cylinder head — left (2)	84 to * — All Models
	19	17033—83A	GASKET KIT, top overhaul	84 to * — All Models
		17035—83B	GASKET KIT, engine overhaul	84 to * — All Models
	20	17355—84	GASKET, rocker cover — lower (2)	84 to * — All Models
	21	17356—84	GASKET, rocker cover — upper (2)	84 to * — All Models
	22	17358—84	GASKET, rocker cover — inner (2)	84 to * — All Models
	23	17360—83	ROCKER ARM, front intake rear ex. (2)	84 to * — All Models
	24	17375—83	ROCKER ARM, rear intake front ex. (2)	84 to * — All Models
	24A	17428—57	BUSHING, rocker arm (8)	84 to * — All Models
	25	17503—84	ROCKER COVER, outer (2)	84 to * — All Models
	26	17510—84	SPACER, rocker covers (2)	84 to * — All Models
	27	17521—84A	ROCKER COVER, inner (2)	84 to * — All Models
	28	17611—83	SHAFT, rocker arm (4)	84 to * — All Models
	29	17921—83	PUSH ROD, rear exhaust — 11.210"	84 to * — All Models
		17922—83	PUSH ROD, rear exhaust — 11.240"	N/A 84 to * — All Models
		17923—83	PUSH ROD, rear exhaust — 11.270"	N/A 84 to * — All Models
		17924—83	PUSH ROD, rear intake — 11.045"	84 to * — All Models
		17925—83	PUSH ROD, rear intake — 11.075"	N/A 84 to * — All Models
		17926—83	PUSH ROD, rear intake — 11.105"	N/A 84 to * — All Models
		17927—83	PUSH ROD, front exhaust — 11.325"	84 to * — All Models
		17928—83	PUSH ROD, front exhaust — 11.355"	N/A 84 to * — All Models
		17929—83	PUSH ROD, front exhaust — 11.385"	N/A 84 to * — All Models
		17930—83	PUSH ROD, front intake — 11.090"	84 to * — All Models
		17931—83	PUSH ROD, front intake — 11.120"	N/A 84 to * — All Models
		17932—83	PUSH ROD, front intake — 11.150"	N/A 84 to * — All Models
	31	17935—79B	COVER, push rod — upper (4)	84 to * — All Models
	32	17938—83	COVER, push rod — lower (4)	84 to * — All Models
	33	17945—36B	CAP, cover spring (4)	84 to * — All Models
	34	17947—36	SPRING, push rod cover (4)	84 to * — All Models
	35	17950—66	RETAINER, spring cap (4)	84 to * — All Models
	36	18523—86	TAPPET, with roller (4)	84 to * — All Models
	37	18540—83A	TAPPET GUIDE, rear	84 to * — All Models
		18542—83	TAPPET GUIDE, front	84 to * — All Models
	38	18633—48C	GASKET, tappet guide — rear	84 to * — All Models
		18634—48B	GASKET, tappet guide — front	84 to * — All Models
	39	63858—49	WASHER (8)	84 to * — All Models

NOTE: PATENT PENDING



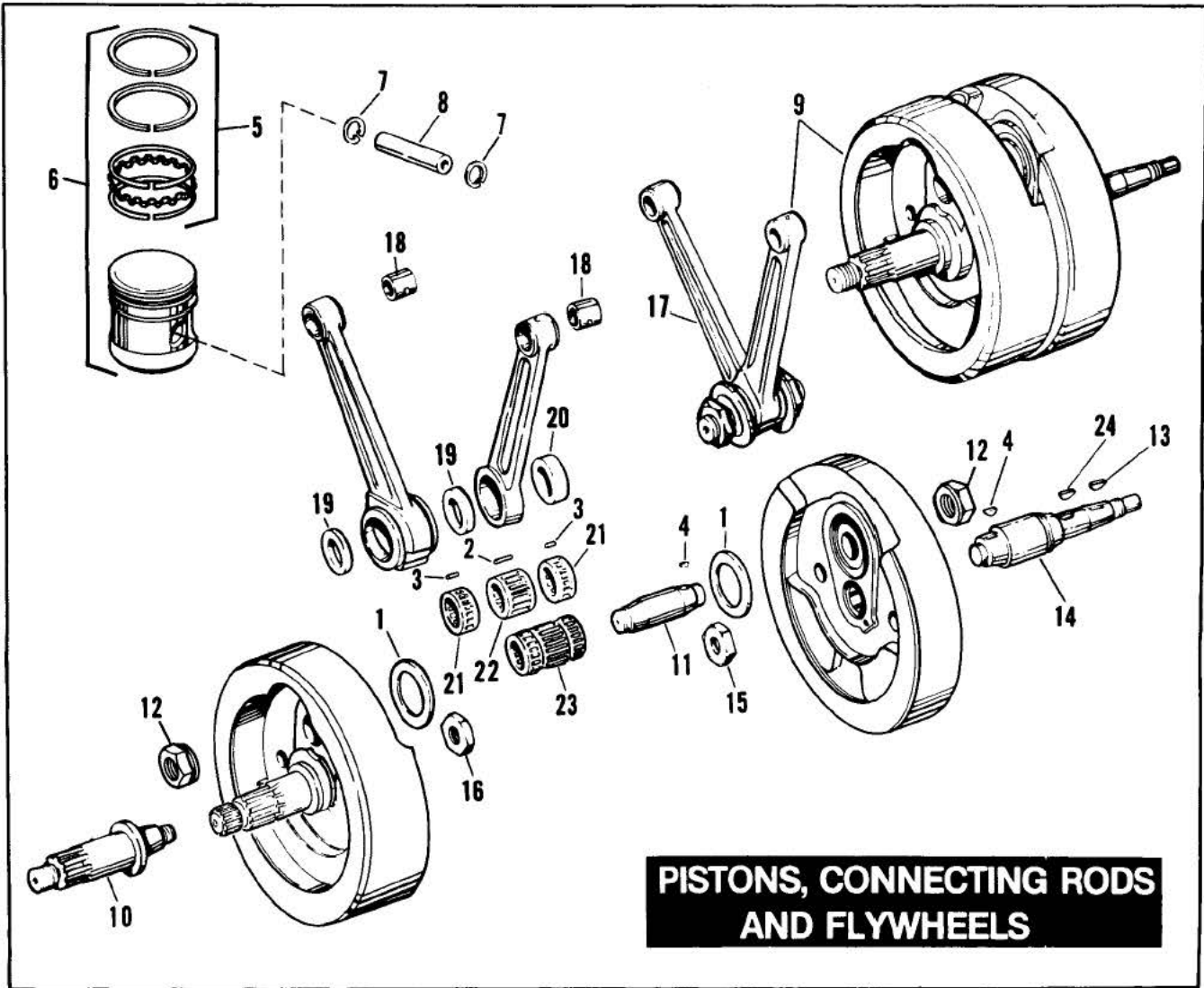

**PISTONS, CONNECTING RODS AND FLYWHEELS**

# PISTONS, CONNECTING RODS & FLYWHEELS

RS3

RETAIL PRICE	INDEX NO.	PART NO.	NAME	USED ON
	1	6506	WASHER, flywheel — bronze (2)	84 to * — All Models
	2	9181	ROLLER, crank pin — 0.0004 O.S. (17)	N/A 84 to * — All Models
		9182	ROLLER, crank pin — 0.0006 O.S. (17)	84 to * — All Models
		9183	ROLLER, crank pin — 0.0008 O.S. (17)	84 to * — All Models
		9184	ROLLER, crank pin — 0.0010 O.S. (17)	N/A 84 to * — All Models
		9185	ROLLER, crank pin — 0.0002 U.S. (17)	84 to * — All Models
		9186	ROLLER, crank pin — standard (17)	N/A 84 to * — All Models
	3	9441A	ROLLER, crank pin — standard (34)	84 to * — All Models
		9443A	ROLLER, crank pin — 0.0004 O.S. (34)	84 to * — All Models
		9444A	ROLLER, crank pin — 0.0006 O.S. (34)	84 to * — All Models
		9445A	ROLLER, crank pin — 0.0008 O.S. (34)	84 to * — All Models
		9446A	ROLLER, crank pin — 0.0010 O.S. (34)	N/A 84 to * — All Models
		9450A	ROLLER, crank pin — 0.0002 U.S. (34)	84 to * — All Models
	4	11218	KEY (2)	84 to * — All Models
	5	21920—83	PISTON RING SET — standard	84 to * — All Models
		21921—83	PISTON RING SET — 0.005 O.S.	84 to * — All Models
		21922—83	PISTON RING SET — 0.010 O.S.	84 to * — All Models
		21923—83	PISTON RING SET — 0.020 O.S.	84 to * — All Models
		21924—83	PISTON RING SET — 0.030 O.S.	84 to * — All Models
	6	21940—83	PISTON AND RINGS ASSEMBLY — standard	84 to * — All Models
		21941—83	PISTON AND RINGS ASSEMBLY — 0.005 O.S.	84 to * — All Models
		21942—83	PISTON AND RINGS ASSEMBLY — 0.010 O.S.	84 to * — All Models
		21943—83	PISTON AND RINGS ASSEMBLY — 0.020 O.S.	84 to * — All Models
		21944—83	PISTON AND RINGS ASSEMBLY — 0.030 O.S.	84 to * — All Models
	7	22589—83	LOCK RING, piston ring (4)	84 to * — All Models
	8	22764—83	PISTON PIN - standard (2)	84 to * — All Models
	9	23906—78G	SET OF FLYWHEELS AND SHAFTS WITH RODS	84 to * — All Models
	10	23909—80	SPROCKET SHAFT	84 & Early 85 — FXRS, FXRT
	11	23961—80A	CRANK PIN	84 to * — All Models
	12	23969—83	NUT, crank pin (2)	84 to * — All Models
	13	23985—54	KEY, gear shaft pinion	84 to * — All Models
	14	24006—83	GEAR SHAFT	84 to * — All Models
	15	24016—80	NUT, gear shaft	84 to * — All Models
	16	24017—80	NUT, sprocket shaft	84 & Early 85 — FXRS, FXRT
	17	24281—83	SET OF CONNECTING RODS WITH BRGS. AND CRANK PIN	84 to * — All Models
	18	24334—36	BUSHING, piston pin — 0.002 O.S. (2)	84 to * — All Models
		24335—36	BUSHING, piston pin — 0.010 O.S.	84 to * — All Models
	19	24345—36A	BUSHING, rear connecting rod — lower (2)	84 to * — All Models
	20	24356—36A	BUSHING, front connecting rod — lower	84 to * — All Models
	21	24366—71	RETAINER, crank pin roller — rear rod (2)	84 to * — All Models
	22	24367—71	RETAINER, crank pin roller — front rod	84 to * — All Models
	23	24385—40B	SET OF ROLLERS AND RETAINERS — standard	N/A 84 to * — All Models
		24387—40B	SET OF ROLLERS AND RETAINERS — 0.0004 O.S.	84 to * — All Models
		24388—40B	SET OF ROLLERS AND RETAINERS — 0.0006 O.S.	84 to * — All Models
		24389—40B	SET OF ROLLERS AND RETAINERS — 0.0008 O.S.	N/A 84 to * — All Models
		24390—40B	SET OF ROLLERS AND RETAINERS — 0.0010 O.S.	N/A 84 to * — All Models
		24391—40B	SET OF ROLLERS AND RETAINERS — 0.0002 U.S.	84 to * — All Models
	24	26348—15	KEY, gear shaft pinion	84 to * — All Models

# CRANKCASE

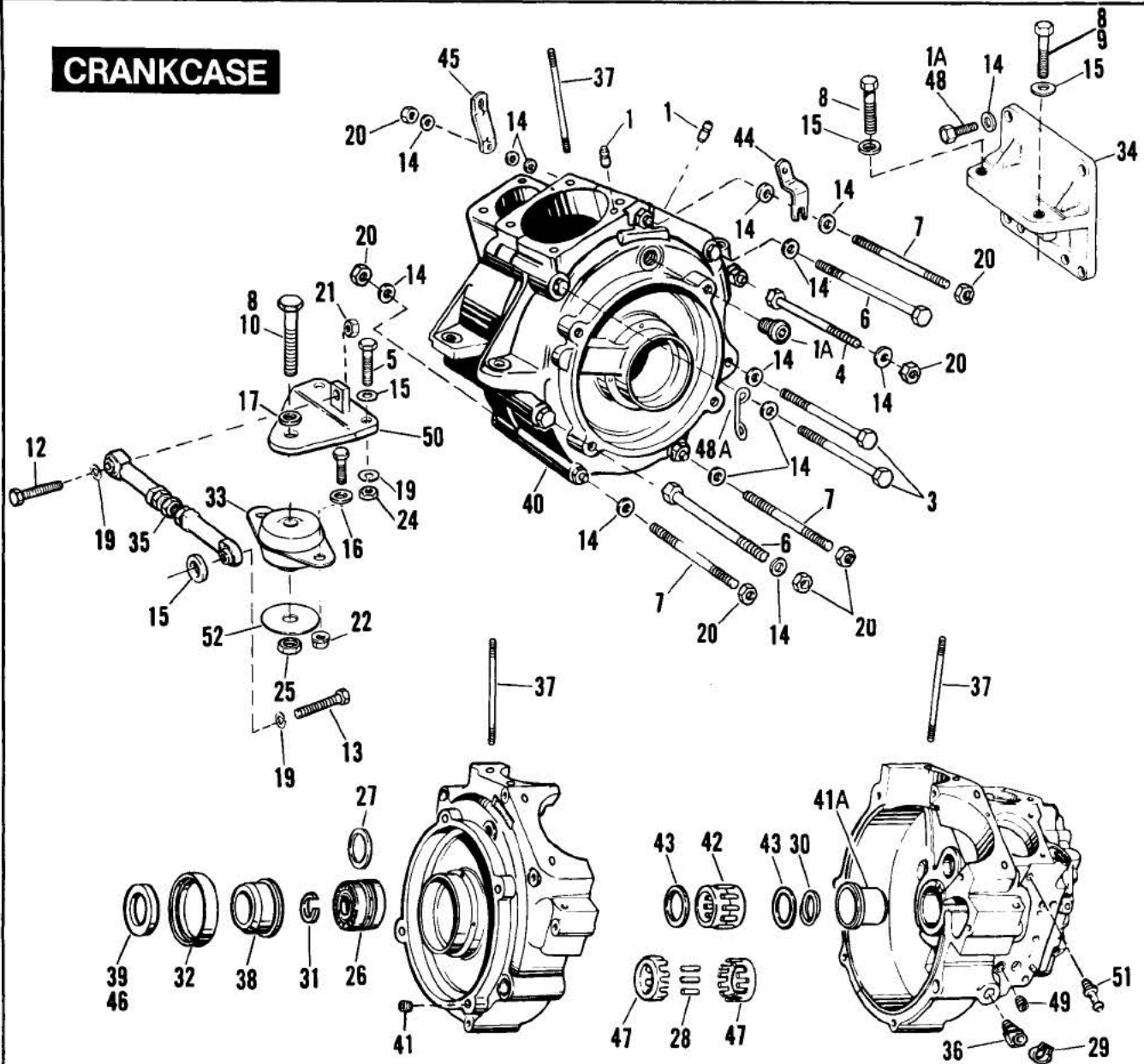

**CRANKCASE**

RETAIL PRICE	INDEX NO.	PART NO.	NAME	USED ON
	1	358	DOWEL PIN (2)	84 to * — All Models
	1A	720	PLUG, timing hole	84 to * — All Models
	2	2889	BOLT (2)	84 — FXRT
	3	3427	BOLT (2)	84 to * — All Models
	4	3430	BOLT	84 to * — All Models
	5	3461	BOLT (2)	84 to * — All Models
	6	3504	BOLT (2)	84 to * — All Models
	7	3506	STUD (3)	84 to * — All Models
	8	3512	BOLT (2 — 85; 3 — 86 & Later)	84 to * — All Models
	9	3513	BOLT	84 & 85 — All Models
	10	3519	BOLT	84 — FXRS, FXRT
	11	4319	BOLT (2)	84 to * — FXRS; 85 to * — FXRT, FXR, FXRD
	12	4716W	BOLT	84 to * — All Models
		4720W	BOLT, upper stabilizer	84 — FXRS, FXRT
	13	4721	BOLT, stabilizer	84 to * — All Models
	14	6016	WASHER (16; 21 — 85; 18 — 86 & Later)	84 to * — All Models
	15	6019	WASHER (5; 7 — 85; 6 — 86 & Later)	84 to * — All Models
	16	6400HB	WASHER (2)	85 to * — All Models
	17	6516HW	WASHER	84 & 85 — FXRS, FXRT
	19	7038	LOCKWASHER (4)	84 to * — All Models
	20	7753	NUT (9)	84 to * — FXRS, FXRT
	21	7778	LOCKNUT	84 — FXRS
	22	7780	LOCKNUT (2)	84 to * — All Models
	24	7783	NUT (2)	84 to * — All Models
	25	7827W	NUT	84 — FXRS, FXRT
		7782	NUT (flanged) (2)	85 to * — All Models
	26	9028	BEARING ASSEMBLY, sprocket shaft (Timken)	84 to * — All Models
	27	9120	SHIM, bearing assembly, 0.0925 - .0915	84 to * — All Models
		9121	SHIM, bearing assembly, 0.0945 - .0935	84 to * — All Models
		9122	SHIM, bearing assembly, 0.0965 - .0955	84 to * — All Models
		9123	SHIM, bearing assembly, 0.0985 - .0975	84 to * — All Models
		9124	SHIM, bearing assembly, 0.1005 - .0995	84 to * — All Models
		9125	SHIM, bearing assembly, 0.1025 - .1015	84 to * — All Models
		9126	SHIM, bearing assembly, 0.1045 - .1035	84 to * — All Models
		9127	SHIM, bearing assembly, 0.1065 - .1055	84 to * — All Models
		9128	SHIM, bearing assembly, 0.1085 - .1075	84 to * — All Models
		9129	SHIM, bearing assembly, 0.1105 - .1095	84 to * — All Models
		9130	SHIM, bearing assembly, 0.1125 - .1115	84 to * — All Models
		9131	SHIM, bearing assembly, 0.1145 - .1135	84 to * — All Models
		9132	SHIM, bearing assembly, 0.1165 - .1155	84 to * — All Models
		9133	SHIM, bearing assembly, 0.1185 - .1175	84 to * — All Models
		9134	SHIM, bearing assembly, 0.1205 - .1195	84 to * — All Models



# CRANKCASE

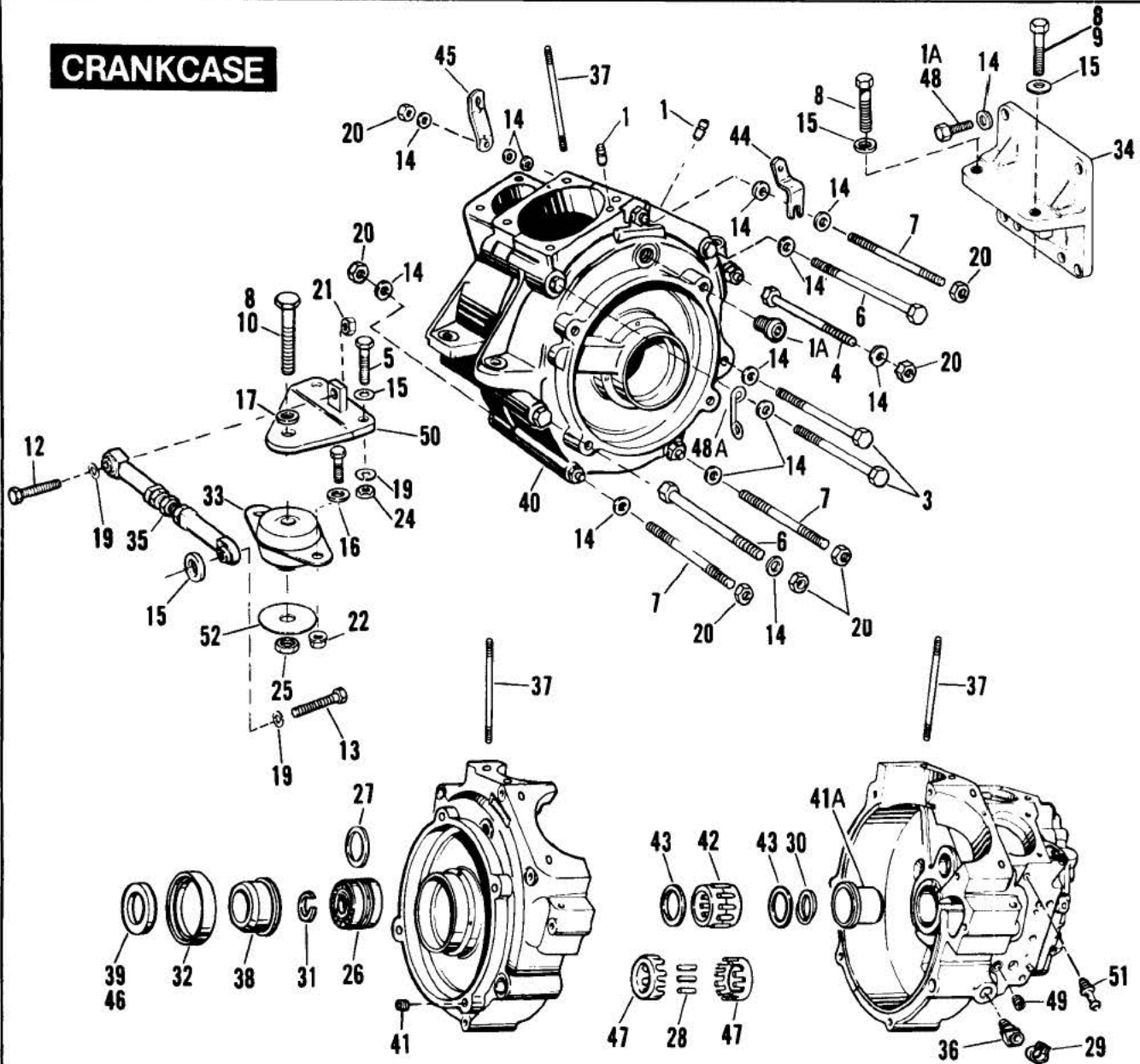

# CRANKCASE (CONT'D)

RETAIL PRICE	INDEX NO.	PART NO.	NAME	USED ON
	28	9217	ROLLER, right bearing — 0.0005 O.S. (28)	84 to * — All Models
		9218	ROLLER, right bearing — 0.0003 O.S. (28)	84 to * — All Models
		9219	ROLLER, right bearing — 0.0001 O.S. (28)	84 to * — All Models
		9221A	ROLLER, right bearing — 0.0002 O.S. (28)	84 to * — All Models
		9222A	ROLLER, right bearing — 0.0004 O.S. (28)	84 to * — All Models
		9223A	ROLLER, right bearing — 0.0006 O.S. (28)	84 to * — All Models
		9224A	ROLLER, right bearing — 0.0008 O.S. (28)	84 to * — All Models
		9225A	ROLLER, right bearing — 0.001 O.S. (28)	84 to * — All Models
	29	10080	CLAMP	Late 84 to * — All Models
	30	11007	RETAINING RING, right bearing	84 to * — All Models
	31	11160	SNAP RING, bearing	84 to * — All Models
	32	12026B	OIL SEAL	84 to * — All Models
	33	16207—79B	ENGINE MOUNT, front	84 to * — All Models
	34	16208—83	BRACKET, engine to transmission	84 — FXRS, FXRT
		16208—85	BRACKET, engine to transmission	85 to * — All Models
	35	16219—79A	STABILIZER LINK	84 to * — All Models
	36	16302—81	FITTING, crankcase	Late 84 to * — All Models
	37	16837—83	STUD, cylinder base (8)	84 & Early 85 — FXRS, FXRT
		16837—85A	STUD, cylinder base (8)	Late 85 to * — All Models
	38	24002—70	SPACER, sprocket shaft	84 to * — All Models
	39	24032—70	SPACER, sprocket shaft — 0.06 thick	84 to * — All Models
		24033—70	SPACER, sprocket shaft — 0.09 thick	84 to * — All Models
		24034—70	SPACER, sprocket shaft — 0.12 thick	84 to * — All Models
		24035—70	SPACER, sprocket shaft — 0.15 thick	84 to * — All Models
		24036—70	SPACER, sprocket shaft — 0.18 thick	84 to * — All Models
		24037—70	SPACER, sprocket shaft — 0.21 thick	84 to * — All Models
	40	24546—83C	CRANKCASE SET	84 to * — All Models
	41	24553—83	INSERT, left crankcase (4)	N/A
	41A	24599—58A	BUSHING, right crankcase — standard	84 to * — All Models
		24600—58A	BUSHING, right crankcase — 0.002 O.S. O.D.	84 to * — All Models
		24601—58A	BUSHING, right crankcase — 0.005 O.S. O.D.	84 to * — All Models
	42	24645—81	RIGHT BEARING — 0.0005 O.S.	84 to * — All Models
		24649—81	RIGHT BEARING — 0.0003 O.S.	84 to * — All Models
		24650—81	RIGHT BEARING — 0.0001 O.S.	84 to * — All Models
		24651—58	RIGHT BEARING — 0.0002 O.S.	84 to * — All Models
		24652—58	RIGHT BEARING — 0.0004 O.S.	84 to * — All Models
		24653—58	RIGHT BEARING — 0.0006 O.S.	84 to * — All Models
		24654—58	RIGHT BEARING — 0.0008 O.S.	84 to * — All Models
		24655—58	RIGHT BEARING — 0.001 O.S.	N/A
	43	24692—58	WASHER, right bearing (2)	84 to * — All Models
	44	25405—82	CLAMP	84 to * — All Models
	45	29290—83	BRACKET	84 & 85 — FXRS, FXRT
		29290—86	BRACKET	N/A
	46	35850—84	SPACER, sprocket shaft — 0.01 thick	84 to * — All Models
		35851—84	SPACER, sprocket shaft — 0.02 thick	84 to * — All Models
		35852—84	SPACER, sprocket shaft — 0.03 thick	84 to * — All Models
	47	43578—35	RETAINER, right roller bearing (2)	84 to * — All Models
	48	43868—72	BOLT, transmission to engine bracket (4)	84 to * — All Models
	48A	45095—85	RETAINER, connector plug	86 to * — All Models
	49	45830—48	PLUG, crankcase oil line	Late 84 to * — All Models
	50	47159—79A	BRACKET, front engine mount	84 to * — All Models
	51	63533—41	FITTING, oil hose	Late 84 to * — All Models
	52	96210—80	WASHER (2)	84 to * — All Models

## CRANKCASE — GEAR SIDE

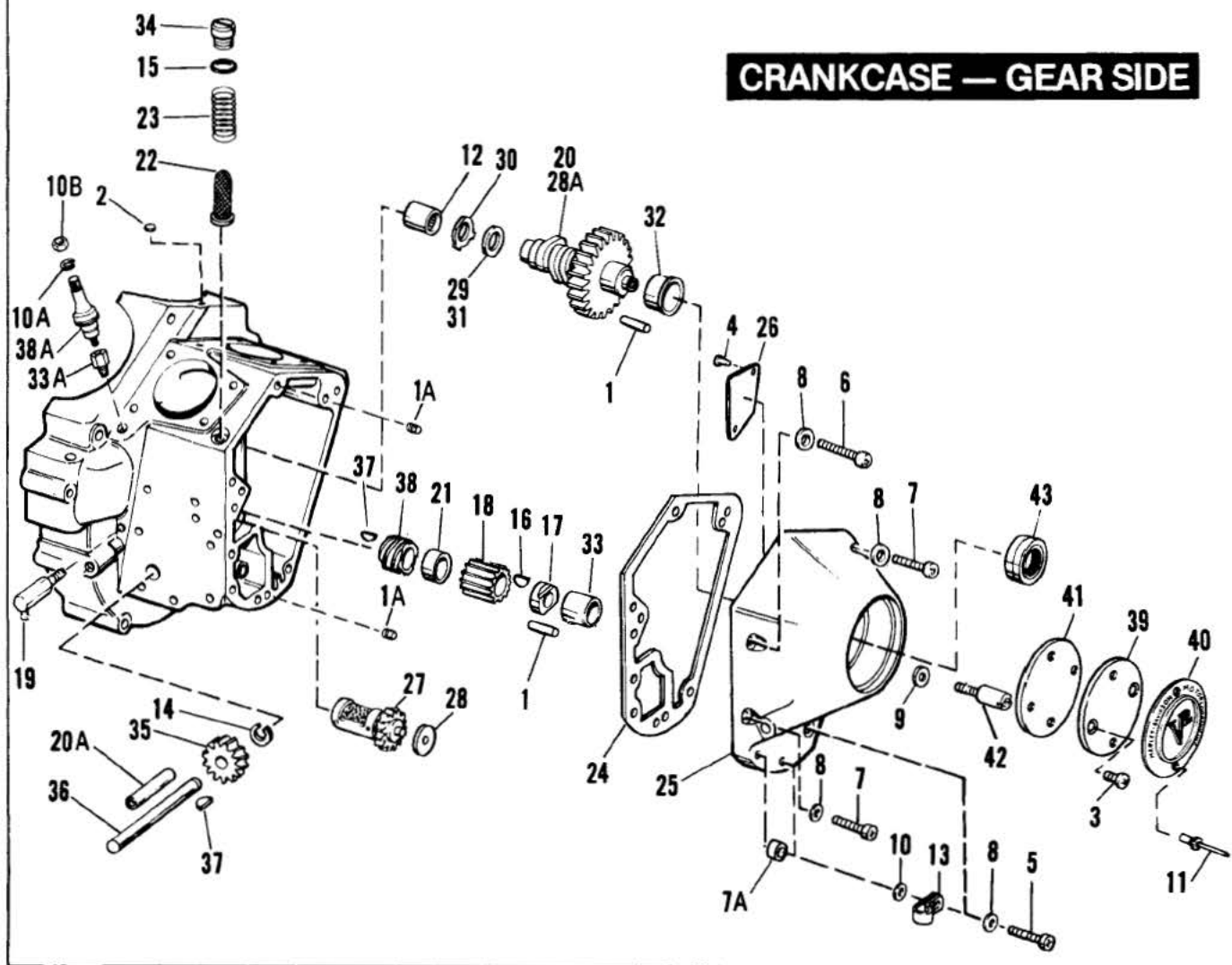

## CRANKCASE — GEARSIDE

RS5-1

RETAIL PRICE	INDEX NO.	PART NO.	NAME	USED ON
	1	275	DOWEL PIN (2 — as required)	84 to * — All Models
	1A	358	DOWEL PIN (2)	84 to * — All Models
	2	653	PLUG, crankcase — gearside	84 to * — All Models
	3	1601	SCREW (2)	84 to * — All Models
	4	2511	SCREW (2)	84 to * — All Models
	5	4718	SCREW (3)	84 to * — All Models
	6	4810	SCREW	84 to * — All Models
	7	4813	SCREW	84 to * — All Models
	7A	5887	SPACER	85 — All Models
	8	6099	WASHER (5)	84 to * — All Models
	9	6194	WASHER (2)	84 & 85 — All Models
	10	6242W	WASHER	84 to * — All Models
	10A	7069	LOCKWASHER	84 to * — FXRS, FXRT; 86 to * — FXR
	10B	7634	NUT	84 to * — FXRS, FXRT; 86 to * — FXR
	11	8699	RIVET, ignition cover (2)	84 to * — All Models
	12	9058	NEEDLE BEARING, crankcase cam gear	84 to * — All Models
	13	10046	CLAMP	84 to * — All Models
	14	11002	RETAINING RING, oil pump drive shaft	84 to * — All Models
	15	11105	O-RING	84 to * — All Models
	16	23985—54	KEY, gear shaft	84 to * — All Models
	17	24023—54	NUT, gear shaft	84 to * — All Models

RETAIL PRICE	INDEX NO.	PART NO.	NAME	USED ON
	18	24040—78	PINION GEAR, 1.4751 - 56 pitch dia. (orange)	84 to * — All Models
		24041—78	PINION GEAR, 1.4745 - 51 pitch dia. (white)	84 to * — All Models
		24042—78	PINION GEAR, 1.4737 - 45 pitch dia. (yellow)	84 to * — All Models
		24043—78	PINION GEAR, 1.4729 - 37 pitch dia. (red)	84 to * — All Models
		24044—78	PINION GEAR, 1.4721 - 29 pitch dia. (blue)	84 to * — All Models
		24045—78	PINION GEAR, 1.4715 - 21 pitch dia. (green)	84 to * — All Models
		24046—78	PINION GEAR, 1.4710 - 15 pitch dia. (black)	84 to * — All Models
	19	24530—79	FITTING, oil line	N/A Early 84 — FXRS, FXRT
	20	24582—83A	CAM AND PINION GEAR SET — matched	84 to * — All Models
	20A	24641—36	BUSHING, oil pump shaft	84 to * — All Models
	21	24703—54B	SPACER, gear shaft pinion	84 to * — All Models
	22	24981—70	OIL SCREEN, crankcase	84 to * — All Models
	23	24982—70	SPRING, oil screen	84 to * — All Models
	24	25225—70B	GASKET, gear cover	84 to * — All Models
	25	25258—80B	GEAR COVER, includes items 4, 26 & 43	84 to * — All Models
	26	25275—82	COVER, breather valve	84 to * — All Models
	27	25313—77C	BREATHER VALVE W/GEAR AND WASHERS (plastic)	84 to * — All Models
	28	25320—82	THRUST WASHER, breather valve - 0.130 thick (plastic)	84 to * — All Models
		25321—82	THRUST WASHER, breather valve - 0.135 thick (plastic)	84 to * — All Models
		25322—82	THRUST WASHER, breather valve - 0.140 thick (plastic)	84 to * — All Models
		25323—82	THRUST WASHER, breather valve - 0.145 thick (plastic)	84 to * — All Models
		25325—82	THRUST WASHER, breather valve - 0.150 thick (plastic)	84 to * — All Models
		25326—82	THRUST WASHER, breather valve - 0.155 thick (plastic)	84 to * — All Models
		25327—82	THRUST WASHER, breather valve - 0.160 thick (plastic)	84 to * — All Models
		25328—82	THRUST WASHER, breather valve - 0.165 thick (plastic)	84 to * — All Models
	28A	25536—84	CAM AND GEAR ASSEMBLY (orange)	N/A 84 to * — All Models
		25537—84	CAM AND GEAR ASSEMBLY (white)	N/A 84 to * — All Models
		25538—84	CAM AND GEAR ASSEMBLY (yellow)	N/A 84 to * — All Models
		25539—84	CAM AND GEAR ASSEMBLY (red)	N/A 84 to * — All Models
		25544—84	CAM AND GEAR ASSEMBLY (blue)	N/A 84 to * — All Models
		25545—84	CAM AND GEAR ASSEMBLY (green)	N/A 84 to * — All Models
		25546—84	CAM AND GEAR ASSEMBLY (black)	N/A 84 to * — All Models
	29	25550—36	THRUST WASHER, cam gear - 0.050 thick	84 to * — All Models
	30	25550—57	LOCKWASHER, cam gear	84 to * — All Models
	31	25555—84	THRUST WASHER, cam gear - 0.045 thick	84 to * — All Models
		25551—36	THRUST WASHER, cam gear - 0.055 thick	84 to * — All Models
		25552—36	THRUST WASHER, cam gear - 0.060 thick	84 to * — All Models
		25553—36	THRUST WASHER, cam gear - 0.065 thick	84 to * — All Models
		25554—36	THRUST WASHER, cam gear - 0.070 thick	84 to * — All Models
		25555—36	THRUST WASHER, cam gear - 0.075 thick	84 to * — All Models
		25556—79	THRUST WASHER, cam gear - 0.080 thick	84 to * — All Models
		25557—79	THRUST WASHER, cam gear - 0.085 thick	84 to * — All Models
		25558—79	THRUST WASHER, cam gear - 0.090 thick	84 to * — All Models
		25559—79	THRUST WASHER, cam gear - 0.095 thick	84 to * — All Models
	32	25581—70	BUSHING, gear cover	84 to * — All Models
	33	25582—73	BUSHING, gear cover pinion shaft	84 to * — All Models
	33A	26052—86	FITTING, oil pressure switch	86 to * — FXRD
	34	26263—80	PLUG, oil	84 to * — All Models
	35	26345—73	DRIVE GEAR, oil pump - 24 T	84 to * — All Models
	36	26346—70	DRIVE SHAFT, oil pump	84 to * — All Models
	37	26348—15	KEY, oil pump gears (2)	84 to * — All Models
	38	26349—73A	DRIVE GEAR, oil pump	84 & Early 85 — FXRS, FXRT
		26349—84	DRIVE GEAR, oil pump	Late 85 to * — All Models
	38A	26561—84	OIL PRESSURE SWITCH	84 to * — FXRS, FXRT; 86 to * — FXR
		77406—86	OIL PRESSURE SWITCH	86 to * — FXRD
	39	32504—80	COVER, inner	84 to * — All Models
	40	32524—83	TIMER COVER, outer	84 to * — All Models
	41	32591—80	GASKET, ignition cover	84 to * — All Models
	42	32606—82	SCREW (2)	84 to * — All Models
	43	83162—51	OIL SEAL, bearing	84 to * — All Models



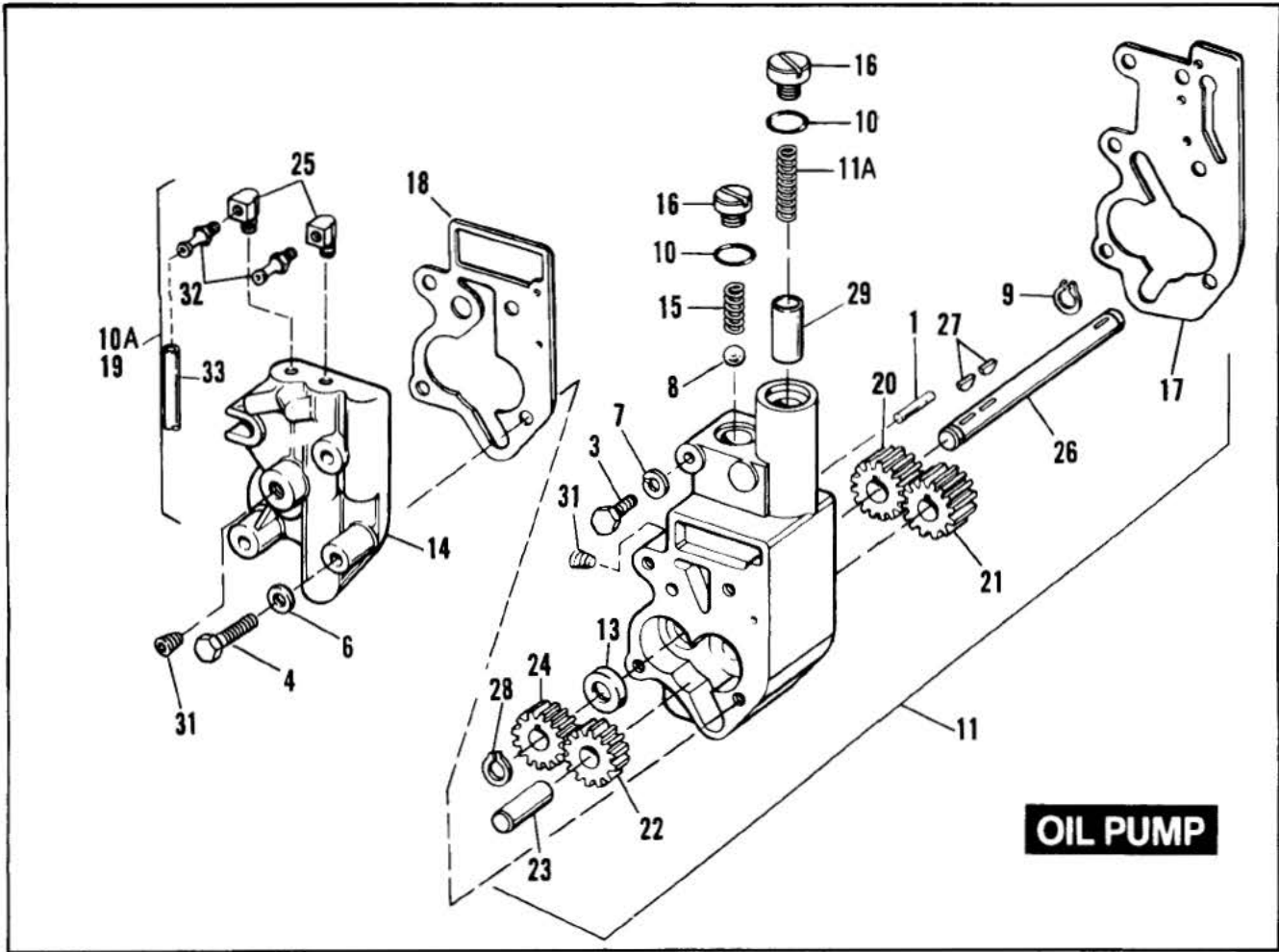

RETAIL PRICE	INDEX NO.	PART NO.	NAME	USED ON
	1	239	DOWEL PIN .....	84 to * — All Models
	3	2872W	BOLT (2) .....	84 to * — All Models
	4	3429	BOLT (4) .....	84 to * — All Models
	6	6736	WASHER (4) .....	84 to * — All Models
	7	7036	LOCKWASHER (2) .....	84 to * — All Models
	8	8873	BALL, check valve, 3/8 dia. ....	84 to * — All Models
	9	11002	RETAINING RING, oil pump .....	84 to * — All Models
	10	11105	O-RING, valve cover screw (2) .....	84 to * — All Models
	10A	26058—84	COVER ASSEMBLY .....	N/A Late 84 to * — All Models
	11	26190—73	OIL PUMP KIT .....	84 to * — All Models
	11A	26207—83	SPRING, relief valve .....	84 to * — All Models
	13	26227—58	OIL SEAL .....	84 to * — All Models
	14	26242—84	COVER, oil pump .....	84 to * — All Models
	15	26262—80	SPRING, check valve .....	84 to * — All Models
	16	26263—80	COVER SCREW, check valve and relief valve (2) .....	84 to * — All Models
	17	26273—80B	GASKET, oil pump body (paper) .....	84 to * — All Models
	18	26276—80A	GASKET, oil pump cover (paper) .....	84 to * — All Models
	19	26285—82A	COVER ASSEMBLY, with fittings .....	N/A Early 84 — FXRS, FXRT
	20	26315—68A	DRIVE GEAR .....	84 to * — All Models
	21	26317—68A	IDLER GEAR .....	84 to * — All Models
	22	26326—62A	DRIVE IDLER GEAR .....	84 to * — All Models
	23	26327—68	IDLER SHAFT .....	84 to * — All Models
	24	26328—74	DRIVE GEAR .....	84 to * — All Models
	25	26338—68	FITTING, 90° (2 — 84 & 85) .....	84 to * — All Models
	26	26346—70	DRIVE SHAFT .....	84 to * — All Models
	27	26348—15	KEY, drive shaft (2) .....	84 to * — All Models
	28	26348—36	RETAINING RING, drive shaft .....	84 to * — All Models
	29	26400—82	VALVE, oil pump .....	84 to * — All Models
	31	43830—48	PLUG (2) .....	84 to * — All Models
	32	63533—41	FITTING (2) .....	84 to * — All Models
	33	63558—85	HOSE, oil pump to oil filter .....	85 to * — All Models

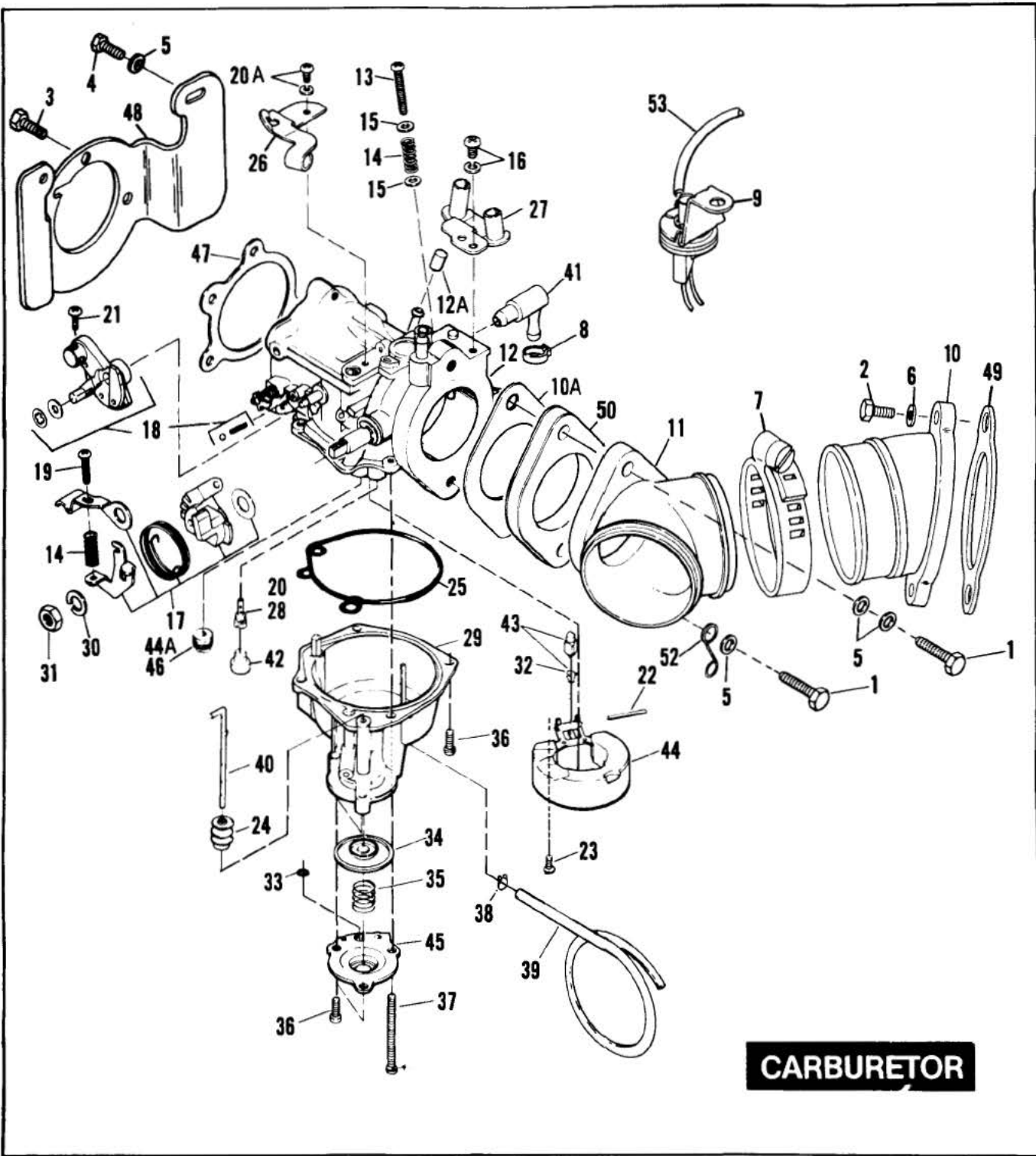

**CARBURETOR**

RETAIL PRICE	INDEX NO.	PART NO.	NAME	USED ON
	1	2871W	BOLT (2)	84 to * — All Models
	2	3494	BOLT (4)	84 to * — All Models
	3	3787	BOLT (3)	84 & 85 — FXRS, FXRT
	4	4017	BOLT (2)	84 & 85 — FXRS, FXRT
	5	6016	WASHER (5; 3 — 86 & Later)	84 to * — All Models
	6	6771	WASHER (4)	84 to * — All Models
	7	9991A	CLAMP (2)	84 to * — All Models
	8	10014	CLAMP, fuel hose (2)	84 to * — All Models
	9	26557—83	VACUUM SWITCH	84 to * — All Models
	10	27008—83A	COMPLIANCE FITTING, front cylinder head	84 to * — All Models
		27012—83A	COMPLIANCE FITTING, rear cylinder head	84 to * — All Models
	10A	27023—71	GASKET	Early 85 — FXRS, FXRT
	11	27019—83	INTAKE MANIFOLD	84 to * — All Models
	12	27029—83D	CARBURETOR (02BL)	84 & 85 — FXRS, FXRT
		27029—86B	CARBURETOR (02BR)	86 to * — All Models
	12A	27079—84	CAP, evaporative port	85 to * — All Models
	13	27130—81	SCREW, throttle stop	84 to * — All Models
	14	27136—81	SPRING, throttle stop screw & fast idle screw (2)	84 to * — All Models
	15	27137—81	WASHER, throttle stop screw (2)	84 to * — All Models
	16	27139—81	SCREW WITH WASHER, throttle cable bracket	84 to * — All Models
	17	27143—81	LEVER KIT, accelerator pump	84 to * — All Models
	18	27144—83	CHOKE LEVER KIT	84 & 85 — FXRS, FXRT
		27144—86A	CHOKE LEVER KIT	86 to * — All Models
	19	27145—81	SCREW, fast idle	84 to * — All Models
	19A	27301—86	MAIN JET, 1.70mm — standard	86 to * — All Models
	20	27302—84	LOW SPEED JET, 0.50mm	Late 84 to * — All Models
	20A	27304—76	SCREW WITH WASHER, choke cable bracket	84 to * — All Models
	21	27307—76	SCREW, wire block	84 to * — All Models
	22	27308—76	PIN, float	84 to * — All Models
	23	27309—76	SCREW, float pin	84 to * — All Models
	24	27311—76	RUBBER CAP, accelerator pump	84 to * — All Models
	25	27324—83	O-RING, bowl	84 to * — All Models
	26	27325—83	BRACKET, choke cable	84 & 85 — FXRS, FXRT
		27325—86	BRACKET, choke cable	86 to * — All Models
	27	27327—83	BRACKET, throttle cable	84 to * — All Models
	28	27329—83	LOW SPEED JET, 0.52mm	Early 84 — FXRS, FXRT
	29	27330—83	BOWL, (02BH)	84 to * — All Models
	30	27333—76	LOCKWASHER, throttle lever	84 to * — All Models
	31	27335—76	NUT, throttle lever	84 to * — All Models
	33	27360—76	O-RING	84 to * — All Models
	34	27361—76	DIAPHRAGM, accelerator pump	84 to * — All Models
	35	27362—76	SPRING, diaphragm	84 to * — All Models
	36	27366—76	SCREW (5)	84 to * — All Models
	37	27367—76	SCREW	84 to * — All Models
	38	27368—76	CLIP, overflow hose	84 to * — All Models
	39	27369—76	HOSE, overflow	84 to * — All Models
	40	27370—83	ROD, accelerator pump	84 to * — All Models
	41	27371—76	FITTING, fuel hose	84 to * — All Models
	42	27385—76	PLUG, low speed jet	84 to * — All Models
	43	27886—78	FLOAT VALVE, with clip	84 to * — All Models
	44	27887—78	FLOAT	84 to * — All Models
	44A	27888—78	MAIN JET, 1.60mm — standard	Late 84 & 85 — FXRS, FXRT
	45	27891—80	HOUSING, accelerator pump	84 to * — All Models
	46	27898—78	MAIN JET, 1.65mm — standard	Early 84 — FXRS, FXRT
	47	29058—77	GASKET, air cleaner to carburetor	84 to * — All Models
	48	29116—83	BRACKET, mounting	84 & 85 — FXRS, FXRT
	49	29242—83	GASKET, compliance fittings (2)	84 to * — All Models
	50	29250—78A	INSULATING SPACER	84 to * — All Models
	52	45092—66A	CABLE GUIDE	84 to * — All Models

NOTE: Hose is sold in bulk length under the following part number. Cut to required length.

53	26570—84	HOSE, 3/16 I.D. x 3/8 O.D. (10 ft. lg.) (black)	Late 84 to * — All Models
----	----------	---	---------------------------



# AIR CLEANER AND CHOKE

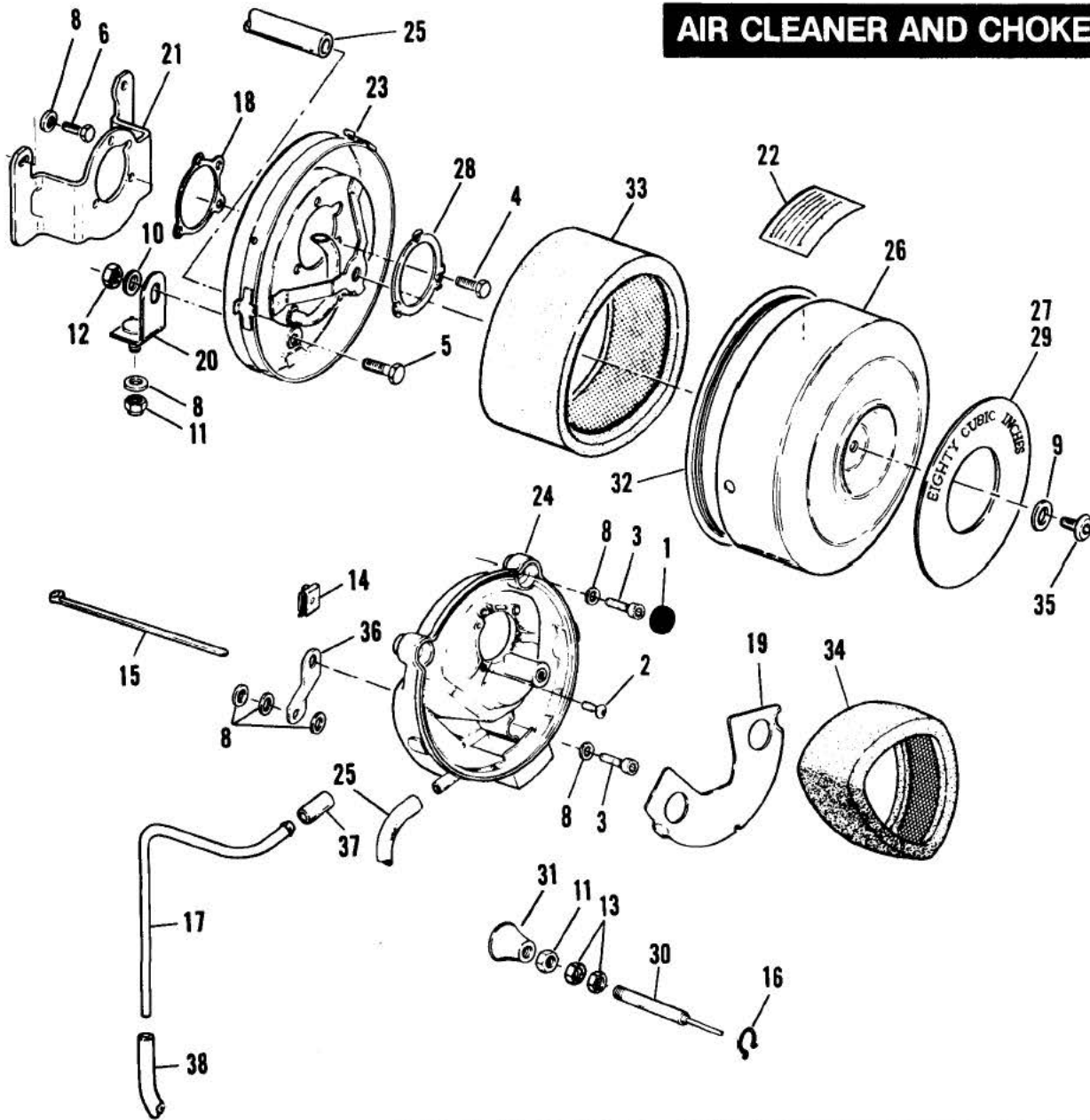

# AIR CLEANER AND CHOKE

RS8

RETAIL PRICE	INDEX NO.	PART NO.	NAME	USED ON
	1	738	PLUG, air cleaner back (2)	86 to * — All Models
	2	864	SCREW (3)	86 to * — All Models
	3	3210	SCREW (3) . . . . . N/A	86 to * — All Models
	4	3787	BOLT (3)	84 & 85 — FXRS, FXRT
	5	3987	BOLT	84 & 85 — FXRS, FXRT
	6	4017	BOLT (2)	84 & 85 — FXRS, FXRT
	8	6016	WASHER (3; 6 — 86 & Later)	84 to * — All Models
	9	6109	WASHER	84 to * — All Models
	10	6702	WASHER	84 & 85 — FXRS, FXRT
	11	7638	NUT (2 — 84 & 85)	84 to * — All Models
	12	7740	LOCKNUT (2 — 85)	84 & 85 — FXRS, FXRT
	13	7744	JAM NUT (3; 2 — 85 & Later)	84 to * — All Models
	14	8102	NUT CLIP	86 to * — All Models
	15	10006	CABLE STRAP	86 to * — All Models
	16	11013	RETAINING RING, choke cable	84 & 85 — FXRS, FXRT
	17	24922—86	VENT TUBE (chrome)	86 to * — FXRD
	18	29058—77	GASKET, air cleaner to carburetor	84 to * — All Models
	19	29068—86	BAFFLE PLATE	86 to * — All Models
	20	29110—83	BRACKET, air cleaner bottom	84 & 85 — FXRS, FXRT
	21	29116—83	BRACKET, air cleaner mounting	84 & 85 — FXRS, FXRT
	22	29126—83	SAFETY LABEL, air cleaner	84 to * — All Models
	23	29134—83A	BACKPLATE, air cleaner	84 & 85 — FXRS, FXRT
	24	29134—86	BACKPLATE, air cleaner	86 to * — All Models
	25	29145—84	HOSE, air cleaner to crankcase	Late 84 & 85 — FXRS, FXRT
		29145—86	HOSE, air cleaner to crankcase	86 to * — FXR, FXRS, FXRT
	26	29165—83A	COVER, air cleaner	84 to * — All Models
	27	29166—83	TRIM, air cleaner "Super Glide II™"	84 — FXRS, FXRT
	28	29168—83A	LOCKPLATE, air cleaner	84 & 85 — FXRS, FXRT
	29	29171—85	TRIM, air cleaner "Low Glide™"	85 — FXRS
		29172—85	TRIM, air cleaner "Low Rider™"	86 to * — FXRS
		29174—85	TRIM, air cleaner "Sport Glide™"	85 to * — FXRT
		29283—86	TRIM, air cleaner "Grand Touring Edition" . . . . . N/A	86 to * — FXRD
	30	29210—86	CONTROL CABLE, choke	86 to * — All Models
		29225—79	CONTROL CABLE, choke	84 & 85 — FXRS, FXRT
	31	29228—80	KNOB, choke wire	84 to * — All Models
	32	29252—86B	SEAL STRIP	86 to * — All Models
	33	29259—83A	FILTER ELEMENT	84 & 85 — FXRS, FXRT
		29202—84	FILTER ELEMENT, foam only	84 & 85 — FXRS, FXRT
	34	29259—86	FILTER ELEMENT	86 to * — All Models
		29293—86	FILTER ELEMENT, foam only	86 to * — All Models
	35	29269—83	SCREW	84 to * — All Models
	36	29290—86	BRACKET, air cleaner . . . . . N/A	86 to * — All Models
	37	63509—86	HOSE (clear)	86 to * — FXRD
	38	63500—68	NOTE: Hose is sold in bulk length under the following part number. Cut to required length. HOSE 3/8 I.D. x 5/8 O.D., reinforced rubber (25 ft.) . . .	86 to * — FXRD

# ALTERNATOR AND REGULATOR

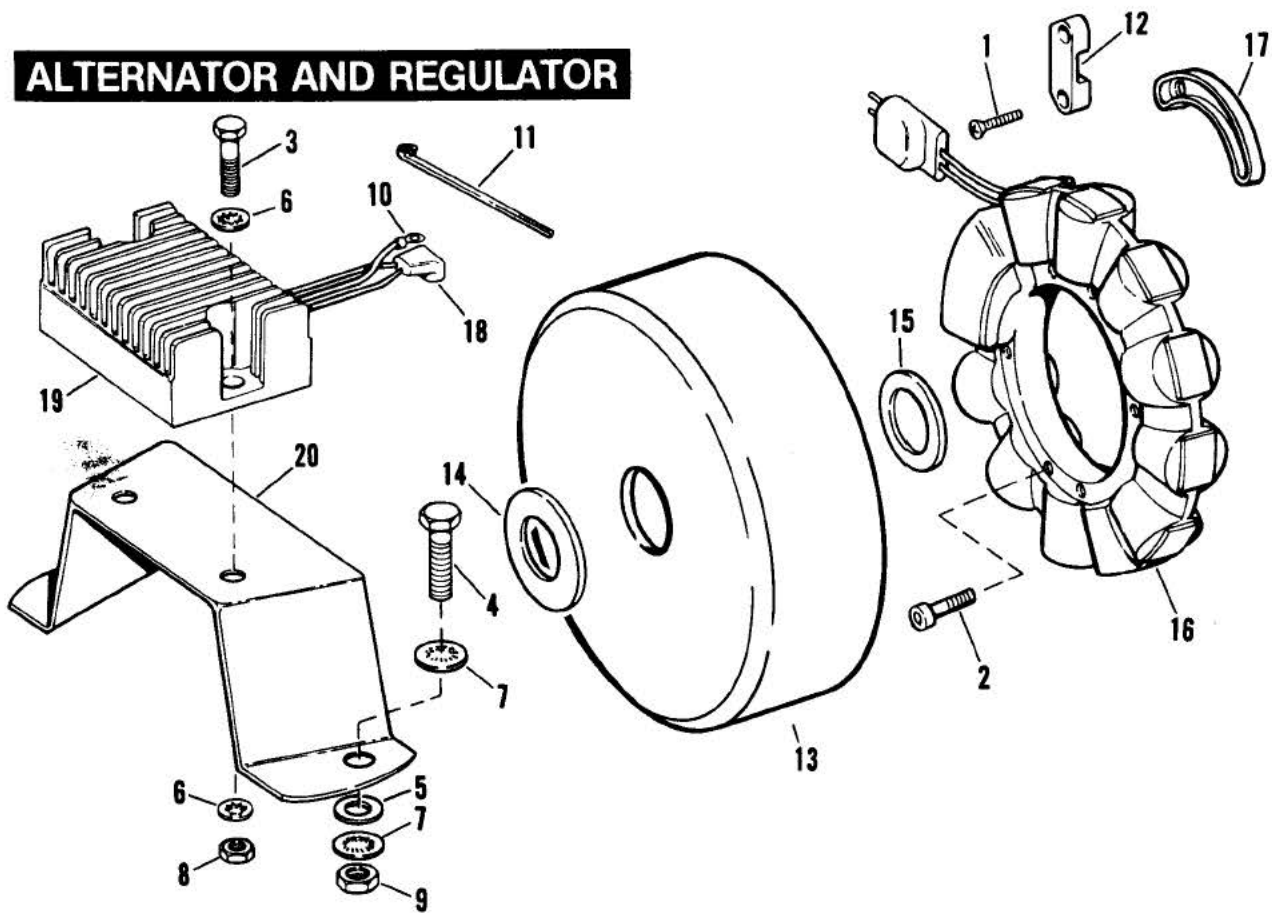

# ALTERNATOR AND REGULATOR

RS9

RETAIL PRICE	INDEX NO.	PART NO.	NAME	USED ON
	1	2216W	SCREW (2)	84 to * — All Models
	2	2653	SCREW (4)	84 & Early 85 — FXRS, FXRT
		2712	SCREW (4)	Late 85 to * — All Models
	3	3787	BOLT (2)	84 to * — All Models
	4	3974HW	BOLT (2)	Early 85 — FXRS, FXRT
		4391	BOLT (2)	84, Late 85 to * — All Models
	5	6109	WASHER (2)	Early 85 — FXRS, FXRT
	6	7124	LOCKWASHER (4)	84 to * — All Models
	7	7127	LOCKWASHER (4)	84 to * — All Models
	8	7688	NUT (2)	84 to * — All Models
	9	7753	NUT (2)	84 to * — All Models
	10	9862	WIRE TERMINAL, ring type, no. 10 hole, #14-16 wire	86 to * — All Models
	11	10065	CABLE STRAP, regulator wiring	Late 84 to * — All Models
	12	29954—71	RETAINER, alternator plug	84 to * — All Models
	13	29957—81B	ROTOR ASSEMBLY	84 to * — All Models
	14	29960—85	SPACER	Late 85 to * — All Models
	15	29961—85	SPACER	Late 85 to * — All Models
	16	29965—81A	STATOR	84 to * — All Models
	17	29988—73	LOCKING PLATE, stator (2)	84 & Early 85 — FXRS, FXRT
	18	71875—81	CONNECTOR, plug	84 to * — All Models
	19	74516—86	REGULATOR	84 to * — All Models
	20	74529—79	BRACKET, regulator mounting	84 to * — All Models

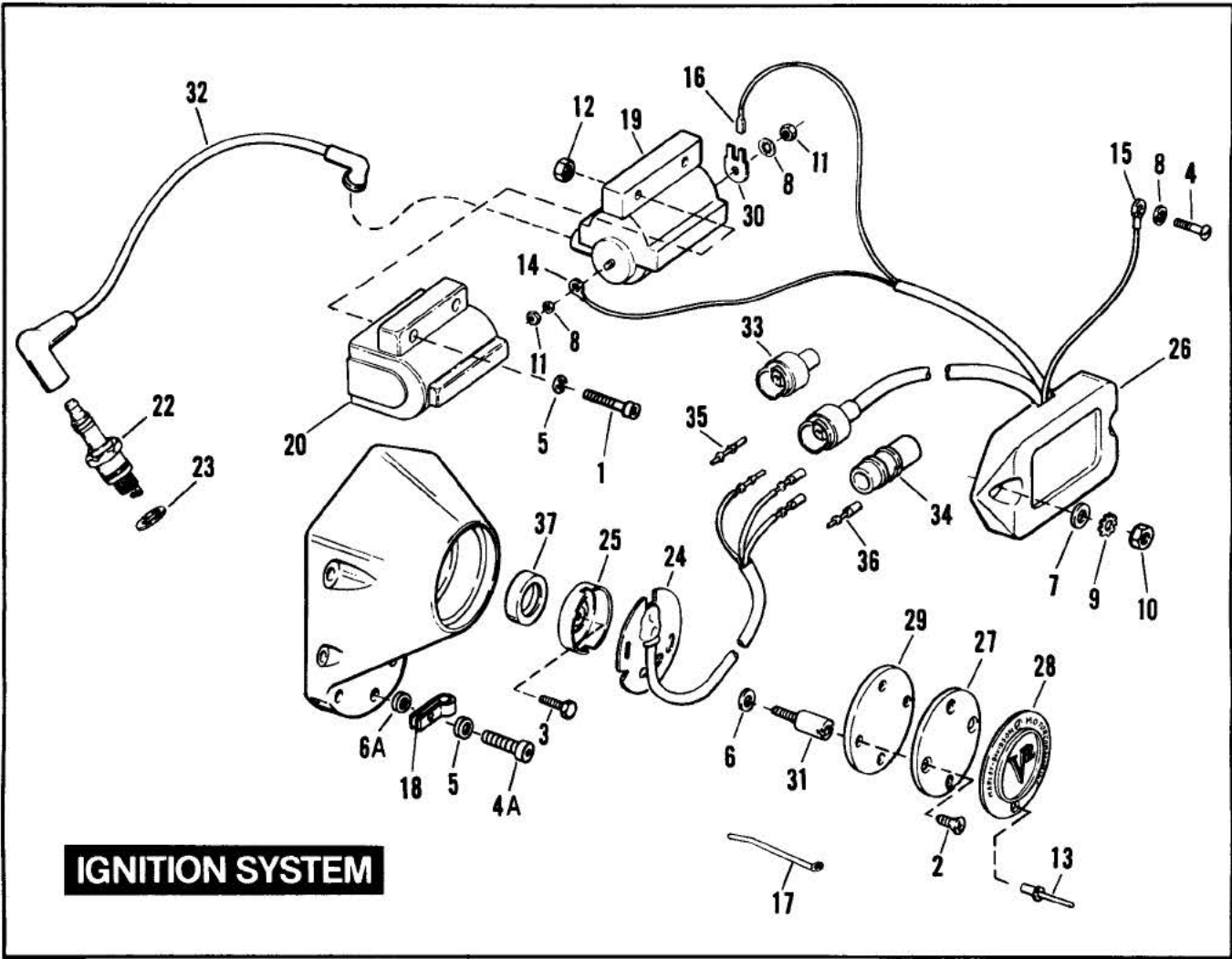

# IGNITION SYSTEM

RS10

RETAIL PRICE	INDEX NO.	PART NO.	NAME	USED ON
	1	812	SCREW (2)	84 to * — All Models
	2	1601	SCREW (2)	84 to * — All Models
	3	2611B	BOLT	84 to * — All Models
	4	2731W	SCREW	84 to * — All Models
	4A	4718	SCREW	84 to * — All Models
	5	6099	WASHER (3)	84 to * — All Models
	6	6194	WASHER (2)	84 & 85 — All Models
	6A	6242W	WASHER	84 to * — All Models
	7	6716	WASHER (2)	84 to * — All Models
	8	7118	LOCKWASHER (3)	84 to * — All Models
	9	7220	LOCKWASHER (2)	84 to * — All Models
	10	7634	NUT (2)	84 to * — All Models
	11	7638	NUT (2)	84 to * — All Models
	12	7686	LOCKNUT (2)	84 to * — All Models
	13	8699	RIVET, ignition cover (2)	84 to * — All Models
	14	9857	WIRE TERMINAL, No. 10 hole (2)	84 to * — All Models
	15	9885	WIRE TERMINAL, socket	84 to * — All Models
	16	9900	WIRE TERMINAL, 3/16 female spade	84 to * — All Models
	17	10006	STRAP, sensor and spark plug cables (3)	85 to * — All Models
	18	10046	CLAMP	84 to * — All Models
	19	31609—80	SPARK COIL	84 — FXRS, FXRT
		31614—83	SPARK COIL	85 to * — All Models
	20	31625—82	COVER, coil	84 to * — All Models
	22	32311—83	SPARK PLUG, No. 5R6A — 0.040 gap (2)	84 to * — All Models
	23	32342—58	GASKET, spark plug (2)	N/A 84 to * — All Models
	24	32400—80A	SENSOR ASSEMBLY	84 to * — All Models
	25	32402—83	ROTOR	84 to * — All Models
	26	32405—88	IGNITION MODULE	84 to * — All Models
	27	32504—80	COVER, inner	84 to * — All Models
	28	32524—83	TIMER COVER	84 to * — All Models
	29	32591—80	GASKET, timer cover	84 to * — All Models
	30	32604—78	TERMINAL ADAPTER	84 to * — All Models
	31	32606—82	SCREW (2)	84 to * — All Models
	32	70187—82	SPARK PLUG CABLE (2)	84 to * — All Models
	33	72051—77	RECEPTACLE PLUG, module	84 to * — All Models
	34	74521—77	RECEPTACLE PLUG, sensor assembly	84 to * — All Models
	35	74536—77A	PIN, plug (3)	84 to * — All Models
	36	74539—77A	SOCKET, plug (3)	84 to * — All Models
	37	83162—51	SEAL	84 to * — All Models

# STARTER SHAFT AND HOUSING

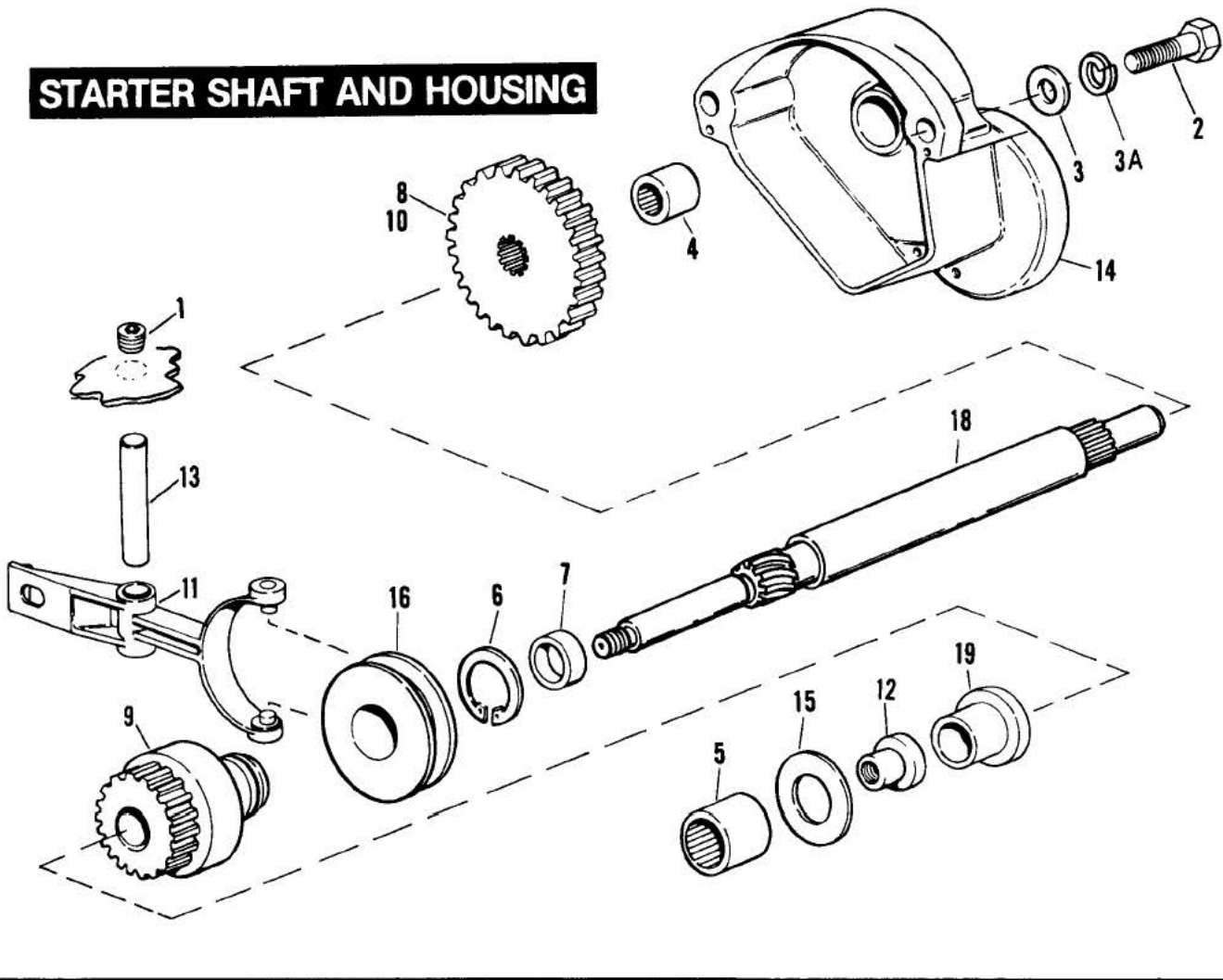



# STARTER SHAFT AND HOUSING

RS11

RETAIL PRICE	INDEX NO.	PART NO.	NAME	USED ON
	1	721	PLUG, shift lever pivot pin .....	84 to * — All Models
	2	2818	BOLT (2) .....	84 — FXRS, FXRT
		2887W	BOLT (2) .....	85 — FXRS, FXRT
		3485	SCREW (2) .....	86 to * — All Models
	3	6016	WASHER (2) .....	84 to * — All Models
	3A	7041	LOCKWASHER (2) .....	86 to * — All Models
	4	9062	NEEDLE BEARING, start shaft housing .....	84 to * — All Models
	5	9063	NEEDLE BEARING, primary cover .....	84 to * — All Models
	6	11039	RETAINING RING, shifter collar .....	84 to * — All Models
	7	11041	SPACER, starter shaft .....	84 — FXRS, FXRT
	8	31340—80	GEAR, starter shaft .....	85 to * — All Models
	9	31443—65A	STARTER DRIVE GEAR UNIT .....	84 to * — All Models
	10	31485—65	GEAR, starter shaft .....	84 — FXRS, FXRT
	11	31491—79	SHIFT LEVER, starter gear .....	84 to * — All Models
	12	31493—67	NUT, starter shaft .....	84 to * — All Models
	13	31495—79	PIVOT PIN, shift lever .....	84 to * — All Models
	14	31497—83	STARTER SHAFT HOUSING, w/9062 BEARING .....	84 & 85 — FXRS, FXRT
		31572—86	STARTER SHAFT HOUSING, w/9062 BEARING .....	86 to * — All Models
	15	31502—65	THRUST WASHER, chain cover .....	84 to * — All Models
	16	31503—65	SHIFTER COLLAR .....	84 to * — All Models
	18	33120—79	STARTER SHAFT .....	84 — FXRS, FXRT
		33120—85	STARTER SHAFT .....	85 to * — All Models
	19	33121—79	SPACER, starter shaft .....	84 to * — All Models

# STARTER MOTOR

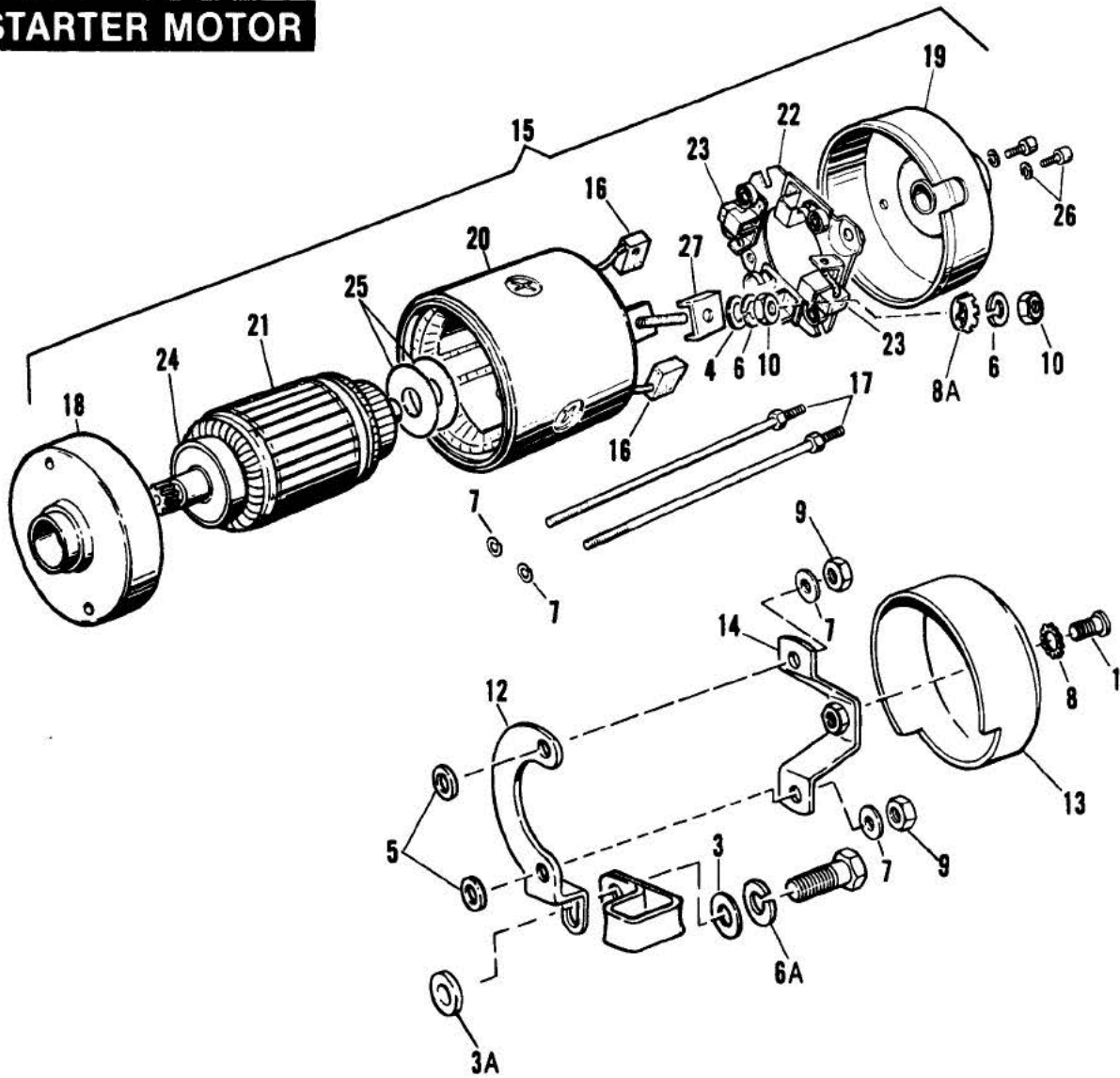

# STARTER MOTOR

RS12

RETAIL PRICE	INDEX NO.	PART NO.	NAME	USED ON
	1	2682	SCREW .....	84 to * — All Models
	2	4017	BOLT .....	84 to * — All Models
	3	6016	WASHER (2) .....	84 to * — All Models
	3A	6701	WASHER .....	84 — FXRS, FXRT
	4	6703	WASHER .....	84 to * — All Models
	5	6716	WASHER (2) .....	84 to * — All Models
	6	7036	LOCKWASHER (2) .....	84 to * — All Models
	6A	7041	LOCKWASHER (2) .....	86 to * — All Models
	7	7069	LOCKWASHER (4) .....	84 to * — All Models
	8	7220	LOCKWASHER .....	84 to * — All Models
	8A	7230	LOCKWASHER .....	86 to * — All Models
	9	7620W	NUT (2) .....	84 to * — All Models
	10	7688	NUT (2) .....	84 to * — All Models
	11	10044	GUIDE, oil hoses .....	84 — FXRS, FXRT
	12	31479—83	BRACKET, starter mounting .....	84 to * — All Models
	13	31524—80	COVER, starter motor .....	84 to * — All Models
	14	31564—83	BRACKET, end cover .....	84 to * — All Models
	15	31570—73	STARTER MOTOR .....	84 to * — All Models
	16	31575—73	BRUSH, field coil mounted (2) .....	84 to * — All Models
	17	31576—73	SET OF THRU-BOLTS .....	84 to * — All Models
	18	31577—73	COVER, drive end .....	84 to * — All Models
	19	31578—73	COVER, commutator end — with bushing .....	84 to * — All Models
	20	31579—73	FRAME AND FIELD COILS, with 2 brushes .....	84 to * — All Models
	21	31580—73	ARMATURE, with ball bearing .....	84 to * — All Models
	22	31581—73	BRUSH HOLDER, with 4 springs and 2 brushes .....	84 to * — All Models
	23	31582—73	BRUSH (2) .....	84 to * — All Models
	24	31583—73	BALL BEARING, armature drive end .....	84 to * — All Models
	25	31584—73	SET OF THRUST WASHERS, armature commutator end .....	84 to * — All Models
	26	31585—73	SCREW, with lockwasher (2) .....	84 to * — All Models
	27	31586—73	INSULATOR, terminal .....	84 to * — All Models

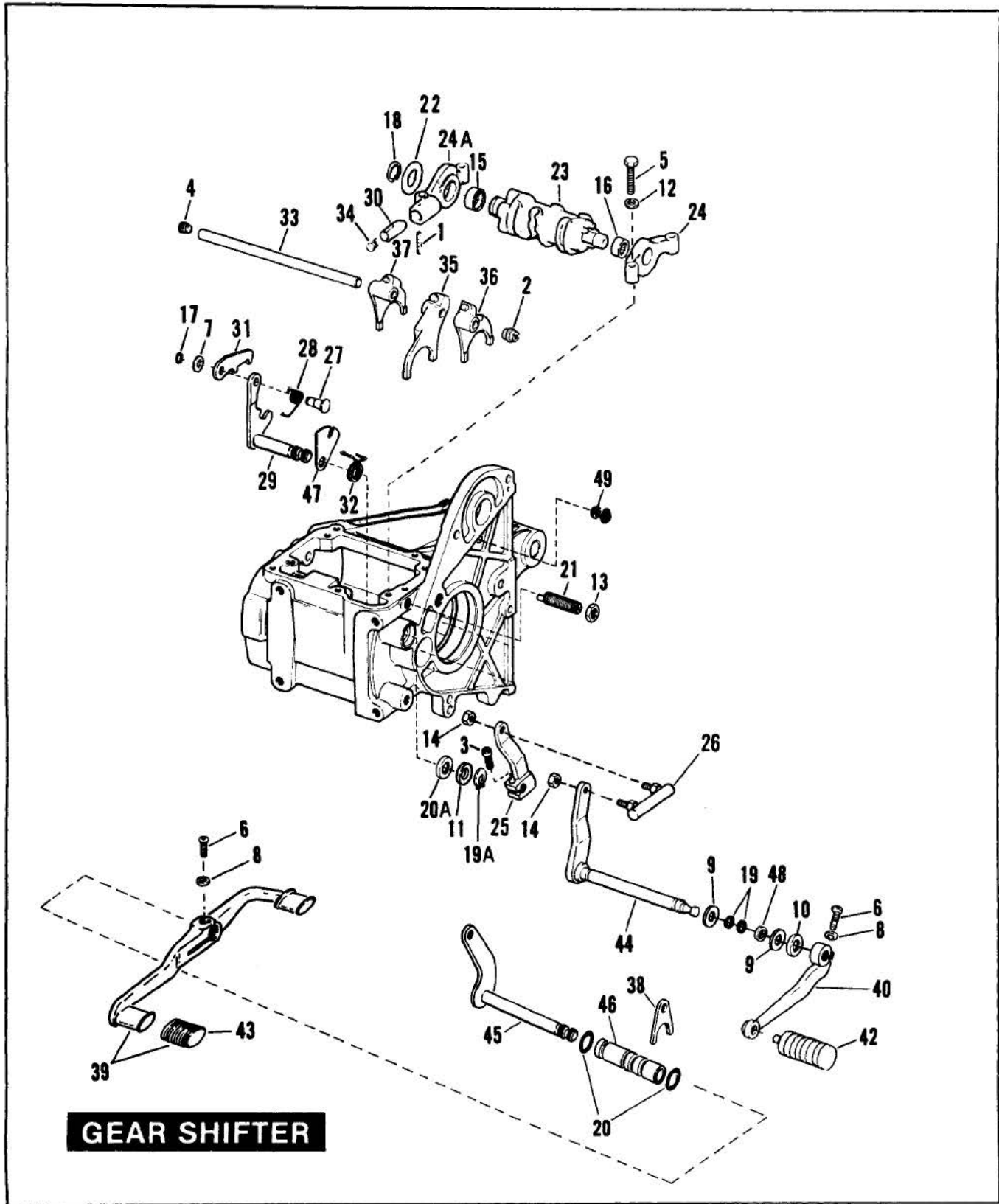

# GEAR SHIFTER

RS13-1

RETAIL PRICE	INDEX NO.	PART NO.	NAME	USED ON
	1	601	ROLL PIN .....	84 to * — All Models
	2	721	PLUG, shifter fork shaft - right .....	84 to * — All Models
	3	856	SCREW .....	84 to * — All Models
	4	3784	SET SCREW, shifter fork shaft - left .....	84 to * — All Models
	5	3993	BOLT (4) .....	84 to * — All Models
	6	4016	BOLT .....	84 to * — FXRS, FXRT; 86 to * — FXR; FXRD
	7	6016	WASHER (as required) .....	84 to * — All Models
	8	6314W	LOCKWASHER .....	84 to * — FXRS, FXRT; 86 to * — FXR; FXRD
	9	6381	WASHER (2) .....	Early 84 — FXRS, FXRT
	10	6409	WASHER .....	Early 84 — FXRS, FXRT
	11	6497HW	WASHER .....	84 to * — All Models
	12	6736	WASHER (4) .....	84 to * — All Models
	13	7515	JAMNUT .....	84 to * — All Models
	14	7744	NUT (2 — 84) .....	84 to * — FXRS, FXRT; 86 to * — FXR
	15	9114	NEEDLE BEARING, right cam support .....	84 to * — All Models
	16	9115	NEEDLE BEARING, left cam support .....	84 to * — All Models
	17	11016	RETAINING RING .....	84 to * — All Models
	18	11083	RETAINING RING .....	84 to * — All Models
	19	11148	QUAD SEAL (2) .....	Early 84 — FXRS, FXRT
	19A	11150	RETAINING RING .....	86 to * — All Models
	20	11117	O-RING, shifter lever sleeve (2) .....	Late 84 to * — All Models
	20A	12045	SEAL .....	84 to * — All Models
	21	33119—79A	ADJUSTING SCREW, shifter arm .....	84 to * — All Models
	22	33205—80	THRUST WASHER, 0.017 thick .....	84 to * — All Models
		33206—80	THRUST WASHER, 0.020 thick .....	84 to * — All Models
		33207—80	THRUST WASHER, 0.022 thick .....	84 to * — All Models
		33208—80	THRUST WASHER, 0.025 thick .....	84 to * — All Models
		33209—80	THRUST WASHER, 0.028 thick .....	84 to * — All Models
		33210—80	THRUST WASHER, 0.031 thick .....	84 to * — All Models
		33211—80	THRUST WASHER, 0.035 thick .....	84 to * — All Models
		33212—80	THRUST WASHER, 0.039 thick .....	84 to * — All Models
	23	33320—79A	SHIFTER CAM .....	84 to * — All Models
	24	33326—79	SUPPORT, shifter cam — left .....	84 to * — All Models
	24A	33332—79	SUPPORT, shifter cam — right .....	84 to * — All Models
	25	33715—80A	LEVER, transmission shifter rod .....	84 — FXRS, FXRT
		33715—85	LEVER, transmission shifter rod .....	85 to * — All Models
	26	33728—82A	BALL JOINT .....	84 to * — All Models
	27	34082—79	PIN, shifter shaft lever .....	84 to * — All Models
	28	34083—79	SPRING, shifter shaft lever .....	84 to * — All Models
	29	34084—80	LEVER, shifter shaft w/pin and spring .....	84 & 85 — FXRS, FXRT
		34084—86	LEVER, shifter shaft w/pin and spring .....	86 to * — All Models
	30	34085—79A	CAM FOLLOWER .....	84 to * — All Models
	31	34086—79	PAWL, shifter cam .....	84 to * — All Models
	32	34087—79	SPRING, shifter shaft .....	84 to * — All Models
	33	34088—79	SHAFT, shifter fork .....	84 to * — All Models
	34	34089—79	SPRING .....	84 to * — All Models

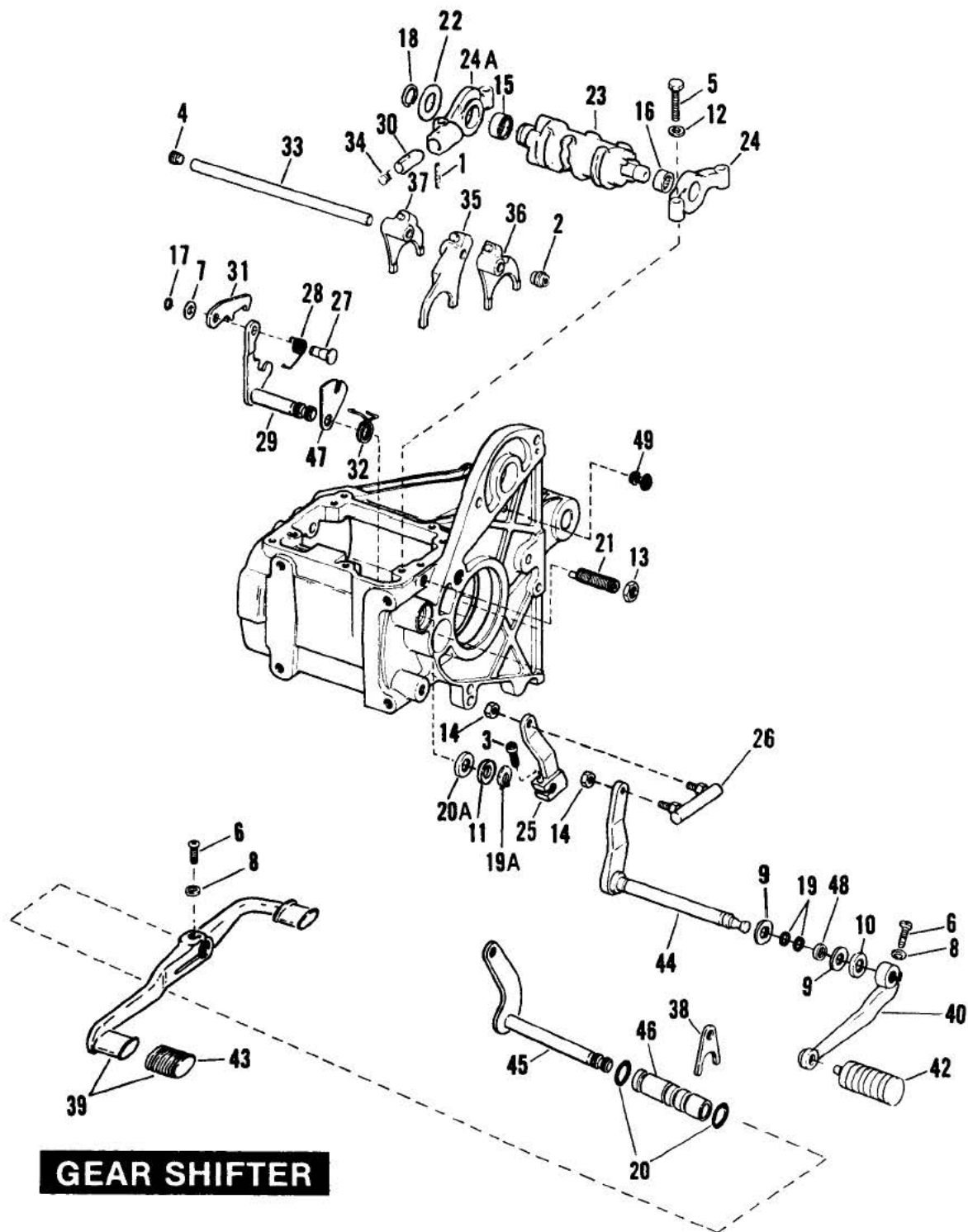

**GEAR SHIFTER (CONT'D)**

**RS13-2**

RETAIL PRICE	INDEX NO.	PART NO.	NAME	USED ON
	35	34191-79C	SHIFTER FORK, 1st & 2nd .....	84 to * - All Models
	36	34193-79C	SHIFTER FORK, 3rd & 5th .....	84 to * - All Models
	37	34195-79C	SHIFTER FORK, 4th .....	84 to * - All Models
	38	34561-84	SLEEVE LOCATOR PLATE .....	Late 84 to * - All Models
	39	34596-86	LEVER, shifter w/covers - heel & toe .....	86 to * - FXRD
		34597-86	LEVER, shifter .....	86 to * - FXRD
	40	34599-81	LEVER, shifter .....	84 to * - FXRS, FXRT; 86 to * - FXR
	42	34611-65	PEG, shifter lever (black) .....	84 to * - FXRS, FXRT; 86 to * - FXR
	43	34619-85	COVER, heel & toe lever (black) (2) .....	86 to * - FXRD
	44	34621-82	SHIFTER LEVER ASSEMBLY .....	Early 84 - FXRS, FXRT
	45	34621-84	SHIFTER LEVER .....	Late 84 to * - FXRS, FXRT; 86 to * - FXR
	46	34632-84	SLEEVE, shift lever .....	Late 84 to * - All Models
	47	35068-79	PLATE .....	84 to * - All Models
	48	60629-82	BUSHING .....	Early 84 - FXRS, FXRT
	49	61082-79	PLUG .....	Early 84 - FXRS, FXRT



# TRANSMISSION HOUSING

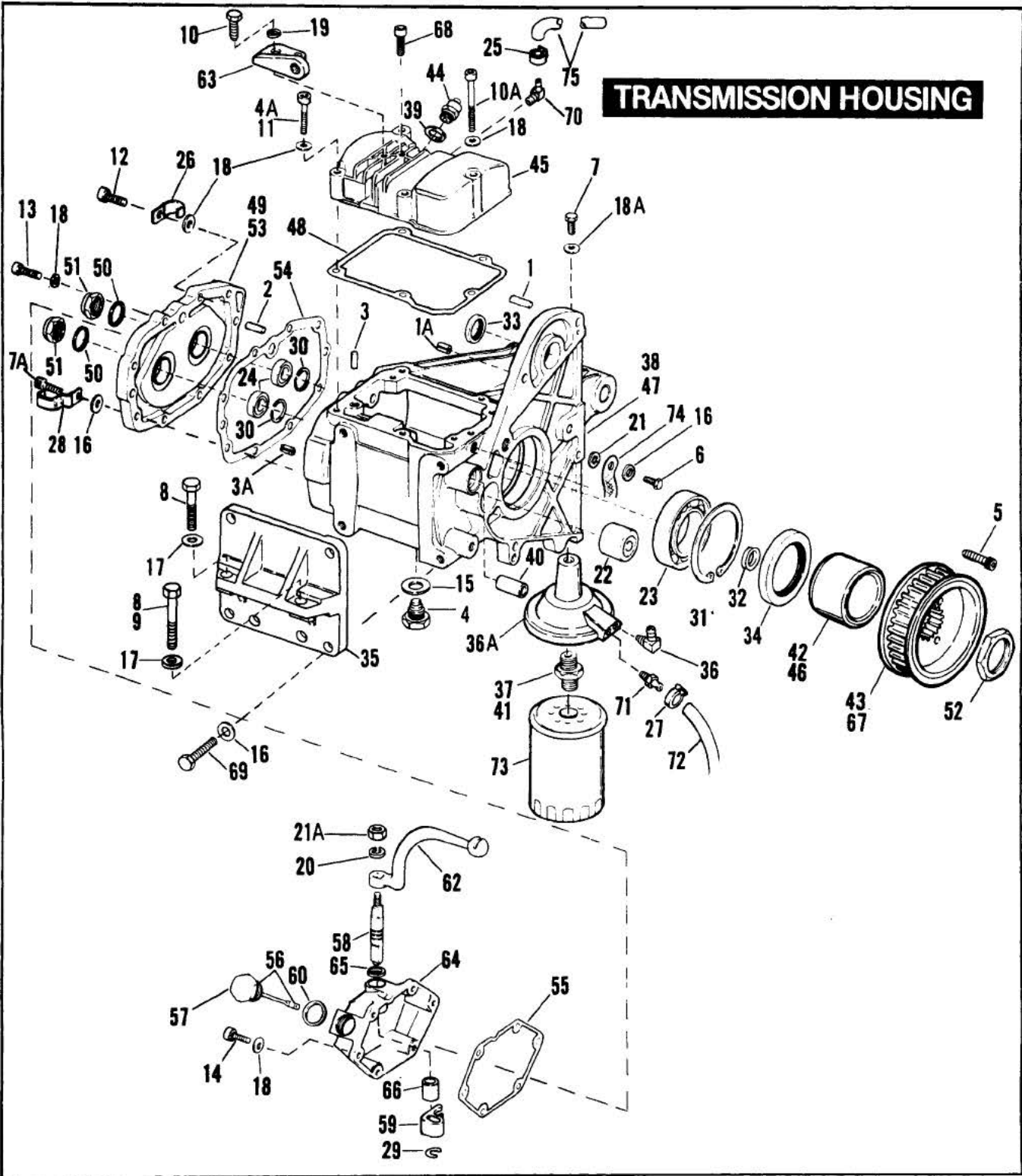

RETAIL PRICE	INDEX NO.	PART NO.	NAME	USED ON
	1	332	DOWEL PIN (2)	84 & 85 — FXRS, FXRT
		335	DOWEL PIN	86 to * — All Models
	1A	336	ROLL PIN	86 to * — All Models
	2	375	DOWEL PIN (3; 2 — 86 & Later)	84 to * — All Models
	3	609	PIN (2)	84 to * — All Models
	3A	634	ROLL PIN	86 to * — All Models
	4	722	DRAIN PLUG, (magnetic)	84 to * — All Models
	5	857	SCREW	84 to * — All Models
	6	2871W	BOLT	85 to * — All Models
	7	2879W	BOLT	85 to * — All Models
	7A	3210	SCREW (4)	84 to * — All Models
	8	3512	BOLT (2 — 86 & Later)	84 to * — All Models
	9	3513	BOLT	84 & 85 — All Models
	10	3787	BOLT (2)	84 to * — All Models
	10A	4717	SCREW	84 to * — All Models
	11	4718	SCREW (4)	84 to * — All Models
	12	4800	SCREW (2)	84 to * — All Models
	13	4814	SCREW (2)	84 to * — All Models
	14	4815	SCREW (6)	84 to * — All Models
	15	6007	WASHER (nylon)	84 to * — All Models
	16	6016	WASHER (9)	84 to * — All Models
	17	6019	WASHER (2 — 84; 3)	84 to * — All Models
	18	6099	WASHER (15)	84 to * — All Models
	18A	6469HW	WASHER	85 — FXRS, FXRT
	19	7036	LOCKWASHER (2)	84 to * — All Models
	20	7041	LOCKWASHER	Late 84 to * — All Models
	21	7127	LOCKWASHER	85 to * — All Models
	21A	7748W	NUT	Late 84 to * — All Models
	22	8977	NEEDLE BEARING	84 to * — All Models
	23	8978	BALL BEARING	Early 84 — FXRS, FXRT
		8996	BALL BEARING, mainshaft — clutch side	Late 84 to * — All Models
	24	8998	BALL BEARING (2)	84 to * — All Models
	25	10014	CLAMP	84 to * — All Models
	26	10070	CLIP	Late 84 to * — All Models
	27	10080	CLAMP (Late 84 — FXRS, FXRT; 4)	86 to * — All Models
	28	10084	CLIP, double hose	Late 84 to * — All Models
	29	11019	RETAINING RING	84 to * — All Models
	30	11020	RETAINING RING, bearing (2)	84 to * — All Models
	31	11057	RETAINING RING, ball bearing	Early 84 — FXRS, FXRT
		11161	RETAINING RING, ball bearing	Late 84 to * — All Models
	32	11165	QUAD SEAL, ball bearing	Late 84 to * — All Models
	33	12043	OIL SEAL	Early 84 — FXRS, FXRT
		12051	OIL SEAL, transmission to starter	Late 84 to * — All Models
	34	12044A	OIL SEAL	Early 84 — FXRS, FXRT
		12050	OIL SEAL, mainshaft — clutch side	Late 84 to * — All Models
	35	16208—83	BRACKET, transmission to engine	84 — FXRS, FXRT
		16208—85	BRACKET, transmission to engine	85 to * — All Models
	36	26338—68	FITTING, oil filter hose	84 — FXRS, FXRT
		26496—75	FITTING, oil filter hose	85 to * — All Models
	36A	26350—85	MOUNTING BRACKET, oil filter	85 to * — All Models
	37	26352—85	ADAPTOR, oil filter	85 to * — All Models
	38	33017—85A	TRANSMISSION, five-speed, rear belt drive	85 — FXRS, FXRT
		33020—86A	TRANSMISSION, five-speed, rear chain drive	Late 86 to * — FXR
	39	33043—80	WASHER, neutral indicator switch	84 to * — All Models
	40	33114—79	SPACER	84 to * — All Models
	41	33115—79	ADAPTER, oil filter	84 — FXRS, FXRT
	42	33334—79	SPACER, sprocket	Early 84 — FXRS, FXRT
		33334—85	SPACER, sprocket	85 to * — FXRS, FXRT; 86 to * — FXRD
		33347—86	SPACER, sprocket	86 to * — FXR

# TRANSMISSION HOUSING

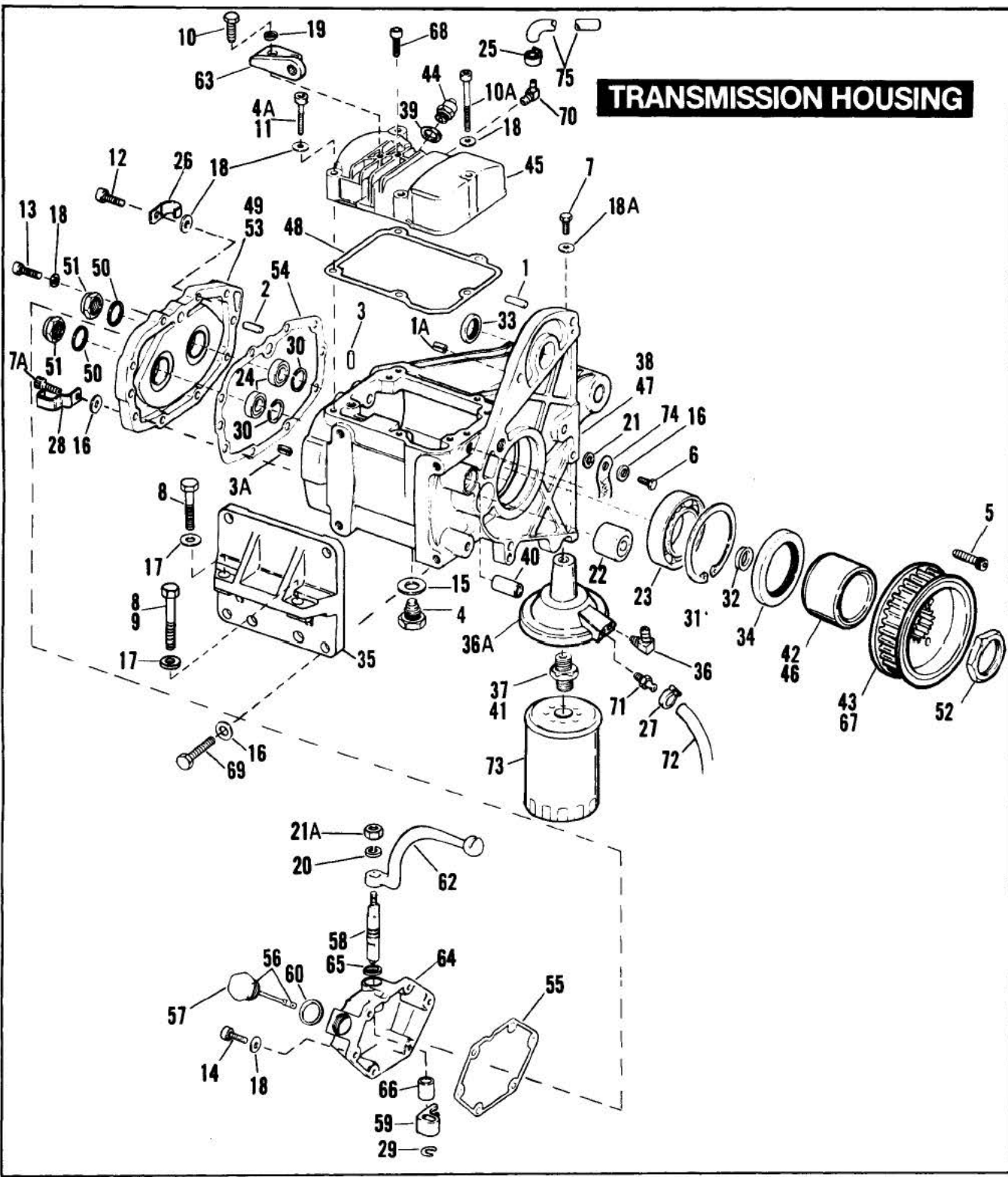

RETAIL PRICE	INDEX NO.	PART NO.	NAME	USED ON
	43	33336-83	SPROCKET, 22 T, with 857 SCREW	84 — FXRS, FXRT
		33339-86	SPROCKET, 22 T	86 to * — FXR
	44	33900-59	SWITCH, transmission neutral indicator	84 to * — All Models
	45	34462-79A	COVER, upper (polished)	84 to * — All Models
	46	34726-84	SPACER, sprocket	Late 84 — FXRS, FXRT
	47	34730-81	TRANSMISSION HOUSING	Early 84 — FXRS, FXRT
		34730-84	TRANSMISSION HOUSING	Late 84 — FXRS, FXRT
		34730-85	TRANSMISSION HOUSING	85 — FXRS, FXRT
		34730-86A	TRANSMISSION HOUSING	86 to * — All Models
	48	34904-79	GASKET, upper cover	84 & 85 — FXRS, FXRT
		34904-86	GASKET, upper cover	86 to * — All Models
	49	35074-79A	HOUSING, only	84 to * — All Models
	50	35076-79	SPACER (2)	84 to * — All Models
	51	35078-79	NUT, mainshaft & countershaft (2)	84 to * — All Models
	52	35211-36	NUT, sprocket	84 to * — All Models
	53	35250-79A	HOUSING, w/bearings & rings	84 to * — All Models N/A
	54	35652-79A	GASKET, bearing housing	84 to * — All Models
	55	36801-79	GASKET, right side cover	84 to * — All Models
	56	37071-79	FILL PLUG, w/dipstick	84 to * — All Models
	57	37072-79	FILL PLUG	84 to * — All Models
	58	37083-80A	STUD, release lever	Late 84 to * — All Models
	59	37084-79	RELEASE FINGER	84 to * — All Models
	60	37091-80	WASHER	84 to * — All Models
	62	37096-83	RELEASE LEVER	84 — FXRS, FXRT
		37096-85	RELEASE LEVER	85 to * — All Models
	63	37098-83	BRACKET, clutch cable	84 — FXRS, FXRT
		37098-85	BRACKET, clutch cable	85 to * — All Models
	64	37100-84	CLUTCH RELEASE COVER ASSEMBLY, includes items 65 & 66	84 to * — All Models
	65	37101-84	OIL SEAL, clutch release lever	84 to * — All Models
	66	37102-84	BUSHING, clutch release lever stud	84 to * — All Models
	67	40210-85A	SPROCKET, 32 T	85 to * — FXRS, FXRT; 86 to * — FXRD
	68	41191-74	SCREW, clutch bracket (2)	84 — FXRS, FXRT
	69	43868-72	BOLT, transmission to engine bracket (4)	84 to * — All Models
	70	62375-57	FITTING, upper cover	84 to * — All Models
	71	63533-41	FITTING, oil filter cover (2 — 84)	84 to * — All Models
	72	63558-84	HOSE, oil pump to oil filter — inlet	Late 84 — FXRS, FXRT
		63558-85	HOSE, oil pump to oil filter	85 to * — All Models
	73	63805-80A	OIL FILTER, standard	84 to * — All Models
	74	70186-82	STRAP, ground	84 to * — All Models
	75	63501-68	NOTE: Hose is sold only in bulk length under the following part number. Cut to required length. HOSE, 1/4 I.D. x 5/8 O.D. reinforced rubber (25 ft. lg.)	84 to * — All Models

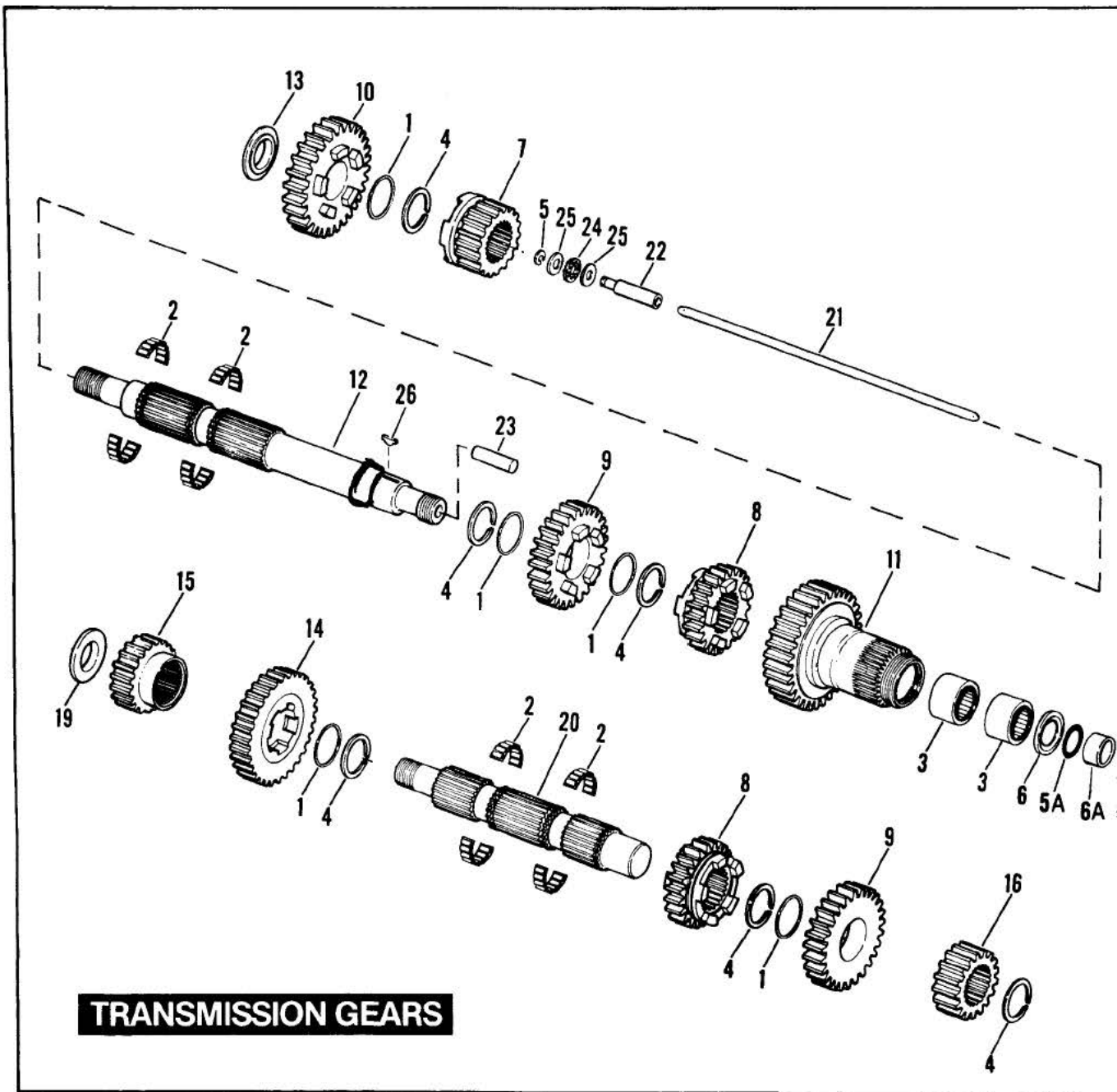

# TRANSMISSION GEARS

RS15

RETAIL PRICE	INDEX NO.	PART NO.	NAME	USED ON
	1	6003	THRUST WASHER (5)	84 to * — All Models
	2	8876A	BEARING (4)	84 to * — All Models
	3	8904	NEEDLE BEARING, mainshaft fifth gear (2)	84 to * — All Models
	4	11067	RETAINING RING (6)	84 to * — All Models
	5	11096	RETAINING RING	84 to * — All Models
	5A	11162	O-RING, mainshaft — right end	Late 84 — FXRS, FXRT
	6	12013A	OIL SEAL, mainshaft fifth gear	84 to * — All Models
	6A	34091—85	BEARING, inner race	85 to * — All Models
	7	35025—79	FIRST GEAR, mainshaft	84 to * — All Models
	8	35026—79A	GEAR, mainshaft second & countershaft third (2)	84 to * — All Models
	9	35027—79A	GEAR, mainshaft third & countershaft second (2)	84 to * — All Models
	10	35028—79	FOURTH GEAR, mainshaft	84 to * — All Models
	11	35029—79	FIFTH GEAR, mainshaft	Early 84 — FXRS, FXRT
		35029—84	FIFTH GEAR, mainshaft	Late 84 — FXRS, FXRT
		35029—85A	FIFTH GEAR, mainshaft	85 to * — All Models
	12	35042—79	MAINSHAFT	Early 84 — FXRS, FXRT
		35042—84	MAINSHAFT	Late 84 — FXRS, FXRT
		35042—85	MAINSHAFT	85 to * — All Models
	13	35064—79	SPACER, mainshaft	84 to * — All Models
	14	35622—79A	FIRST GEAR, countershaft	84 to * — All Models
	15	35625—79A	FOURTH GEAR, countershaft	84 to * — All Models
	16	35626—79A	FIFTH GEAR, countershaft	84 to * — All Models
	19	35629—79	SPACER	84 to * — All Models
	20	35632—79	COUNTERSHAFT	84 to * — All Models
	21	37088—79	PUSH ROD, clutch release (thru mainshaft)	Early 84 — FXRS, FXRT
		37088—84	PUSH ROD, clutch release (thru mainshaft)	Late 84 — FXRS, FXRT
		37088—85	PUSH ROD, clutch release	85 to * — All Models
	22	37089—79	END, push rod — right side	Early 84 — FXRS, FXRT
		37089—84	ROD END, clutch push rod — right	Late 84 to * — All Models
	23	37090—79	END, push rod — left side	Early 84 — FXRS, FXRT
		37090—84	ROD END, clutch push rod — left	Late 84 to * — All Models
	24	37312—75	BEARING	84 to * — All Models
	25	37313—80	THRUST WASHER (2)	84 to * — All Models
	26	37523—85	KEY, clutch	Late 85 to * — All Models

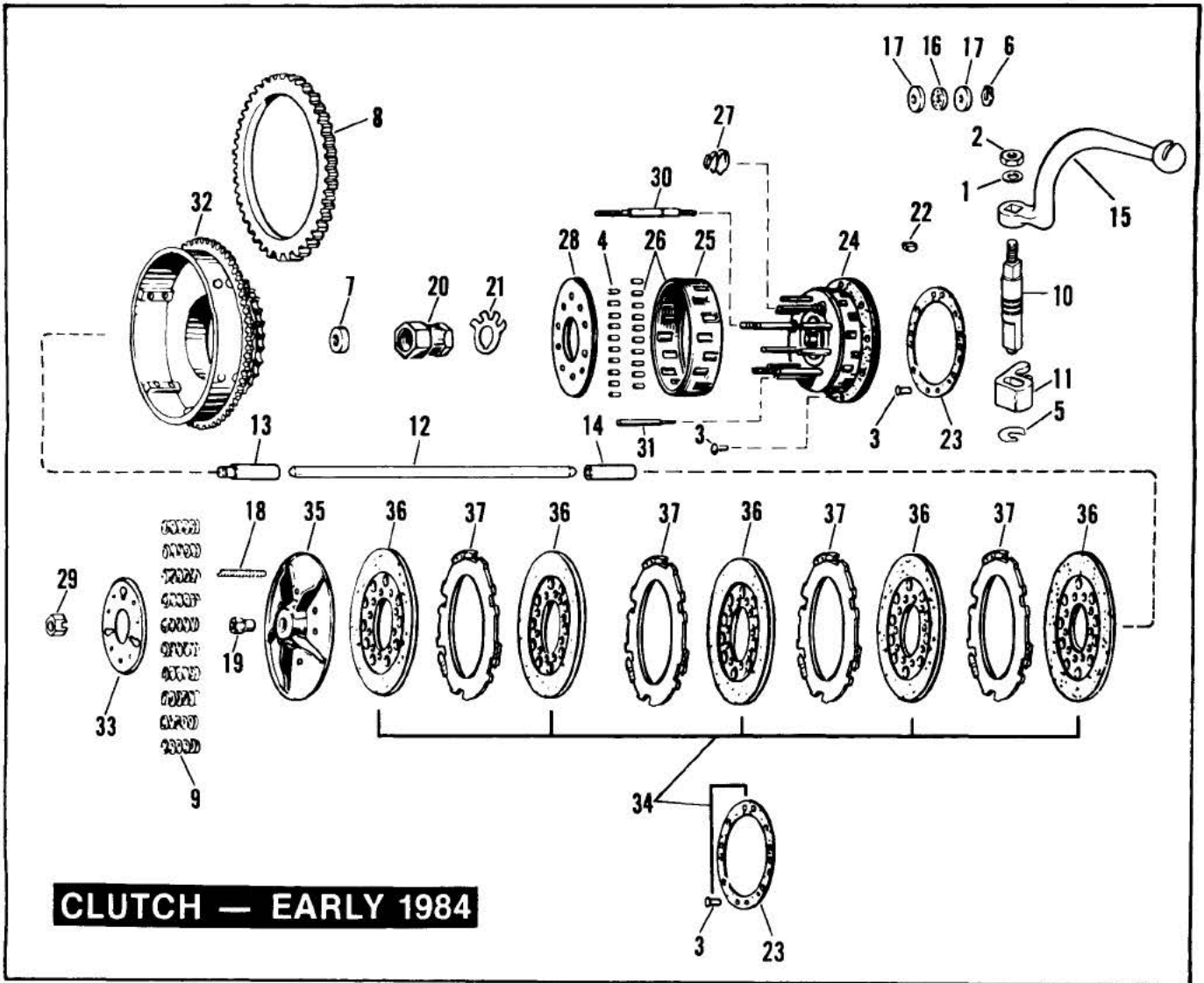

**CLUTCH — EARLY 1984**



RETAIL PRICE	INDEX NO.	PART NO.	NAME	USED ON
	1	7041	LOCKWASHER .....	Early 84 — FXRS, FXRT
	2	7748W	NUT .....	Early 84 — FXRS, FXRT
	3	8227	RIVET (8) .....	Early 84 — FXRS, FXRT
	4	9540A	ROLLER, clutch hub bearing (20) .....	Early 84 — FXRS, FXRT
	5	11019	RETAINING RING .....	Early 84 — FXRS, FXRT
	6	11096	RETAINING RING .....	Early 84 — FXRS, FXRT
	7	12014	OIL SEAL, mainshaft nut .....	Early 84 — FXRS, FXRT
	8	33163—65B	STARTER RING GEAR .....	Early 84 — FXRS, FXRT
	9	37077—68	CLUTCH SPRING (10) .....	Early 84 — FXRS, FXRT
	10	37083—80A	STUD, release lever .....	Early 84 — FXRS, FXRT
	11	37084—79	RELEASE FINGER .....	Early 84 — FXRS, FXRT
	12	37088—79	PUSH ROD, clutch release (thru mainshaft) .....	Early 84 — FXRS, FXRT
	13	37089—79	END, push rod - right side .....	Early 84 — FXRS, FXRT
	14	37090—79	END, push rod - left side .....	Early 84 — FXRS, FXRT
	15	37096—83	RELEASE LEVER .....	Early 84 — FXRS, FXRT
	16	37312—75	BEARING, push rod .....	Early 84 — FXRS, FXRT
	17	37313—80	THRUST WASHER (2) .....	Early 84 — FXRS, FXRT
	18	37357—41	ADJUSTING SCREW, push rod .....	Early 84 — FXRS, FXRT
	19	37361—41	NUT, adjusting screw .....	Early 84 — FXRS, FXRT
	20	37496—65	NUT, mainshaft (clutch side) .....	Early 84 — FXRS, FXRT
	21	37503—41	LOCKWASHER, clutch nut .....	Early 84 — FXRS, FXRT
	22	37523—15A	KEY, clutch .....	Early 84 — FXRS, FXRT
	23	37549—41	LINING, hub friction disc .....	Early 84 — FXRS, FXRT
	24	37550—41B	CLUTCH HUB ASSEMBLY .....	Early 84 — FXRS, FXRT
	25	37566—58	RETAINER, clutch hub roller .....	Early 84 — FXRS, FXRT
	26	37567—41A	RETAINER, clutch hub roller w/rollers .....	Early 84 — FXRS, FXRT
	27	37574—44	SPRING, hub bearing plate (2) .....	Early 84 — FXRS, FXRT
	28	37576—41	PLATE, hub bearing .....	Early 84 — FXRS, FXRT
	29	37581—47	NUT, hub stud (3) .....	Early 84 — FXRS, FXRT
	30	37583—41	STUD, drive hub (3) .....	Early 84 — FXRS, FXRT
	31	37585—41	PIN, clutch hub (7) .....	Early 84 — FXRS, FXRT
	32	37702—70A	CLUTCH SHELL AND SPROCKET, w/starter ring gear ..	Early 84 — FXRS, FXRT
	33	37816—41	PRESSURE PLATE .....	Early 84 — FXRS, FXRT
	34	37850—68	SET OF LINED CLUTCH DISCS .....	Early 84 — FXRS, FXRT
	35	37871—41	RELEASING DISC .....	Early 84 — FXRS, FXRT
	36	37930—68A	FRICTION DISC (5) .....	Early 84 — FXRS, FXRT
	37	37975—81	DRIVE DISC (steel) (4) .....	Early 84 — FXRS, FXRT

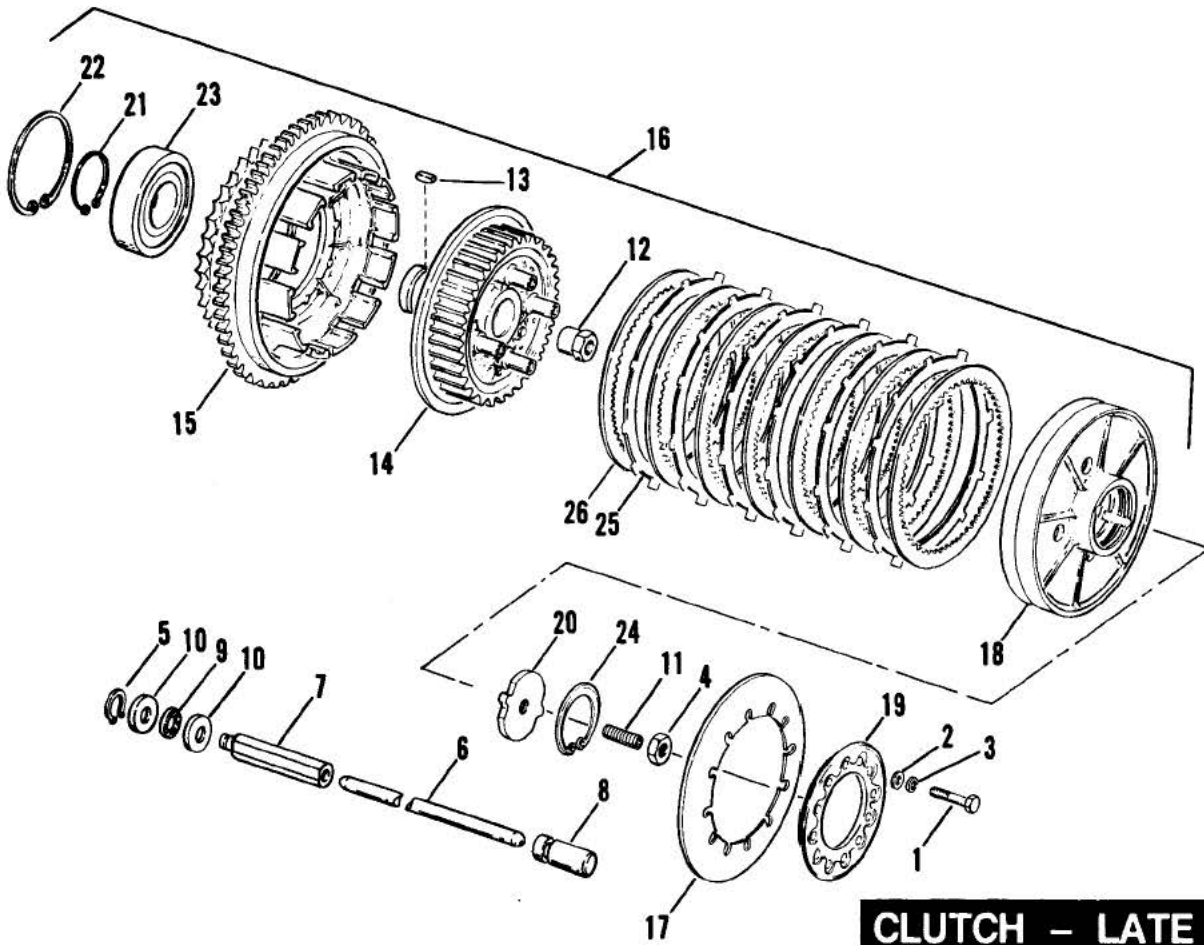

**CLUTCH - LATE  
1984 & LATER**

# CLUTCH — LATE 1984 & LATER

RS16A

RETAIL PRICE	INDEX NO.	PART NO.	NAME	USED ON
	1	2881W	BOLT (4)	Late 84 to * — All Models
	2	6099	WASHER (4)	Late 84 to * — All Models
	3	7036	LOCKWASHER (4)	Late 84 to * — All Models
	4	7848W	NUT	Late 84 to * — All Models
	5	11096	RETAINING RING	Late 84 to * — All Models
	6	37088—84	PUSH ROD, clutch release (thru mainshaft)	Late 84 — FXRS, FXRT
		37088—85	PUSH ROD, clutch release	85 to * — All Models
	7	37089—84	END, push rod — right side	Late 84 to * — All Models
	8	37090—84	END, push rod — left side	Late 84 to * — All Models
	9	37312—75	BEARING, push rod	Late 84 to * — All Models
	10	37313—80	THRUST WASHER (2)	Late 84 to * — All Models
	11	37357—84	ADJUSTING STUD, push rod	Late 84 to * — All Models
	12	37496—84	NUT, mainshaft (clutch side)	Late 84 to * — All Models
	13	37523—15A	KEY, clutch	Late 84 & Early 85 — FXRS, FXRT
		37523—85	KEY, clutch	Late 85 to * — All Models
	14	37550—84	CLUTCH HUB, inner	Late 84 to * — All Models
	15	37702—84	CLUTCH SHELL & SPROCKET, w/starter ring gear	Late 84 — FXRS, FXRT
		37707—84	CLUTCH SHELL & SPROCKET, w/starter ring gear	85 to * — All Models
	16	37800—84	CLUTCH ASSEMBLY	85 to * — All Models
		37801—84	CLUTCH ASSEMBLY	Late 84 — FXRS, FXRT
	17	37871—84	DIAPHRAGM SPRING PLATE	Late 84 to * — All Models
	18	37901—84	PRESSURE PLATE	Late 84 — FXRS, FXRT
	19	37902—84A	ADJUSTER PLATE	Late 84 to * — All Models
	20	27903—84	RELEASE PLATE, center	Late 84 to * — All Models
	21	37904—84	RETAINING RING, internal — bearing	Late 84 to * — All Models
	22	37905—84	RETAINING RING, external — bearing	Late 84 to * — All Models
	23	37906—84	BEARING, clutch assembly	Late 84 to * — All Models
	24	37907—84	RETAINING RING, pressure plate	Late 84 to * — All Models
	25	37931—84	FRICTION DISC (6)	Late 84 to * — All Models
	26	37975—84	DRIVE DISC (7)	Late 84 to * — All Models

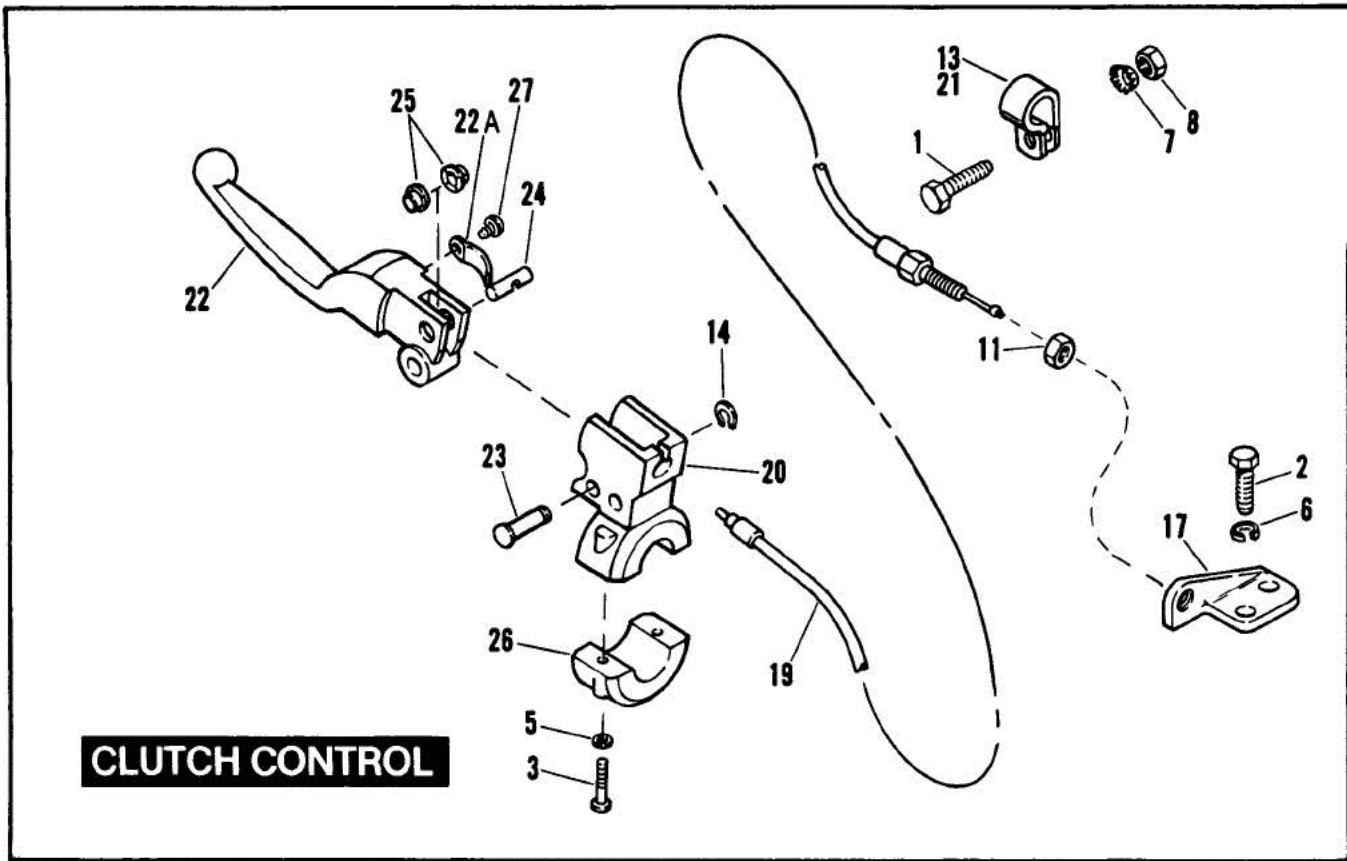

# CLUTCH CONTROL

RS17

RETAIL PRICE	INDEX NO.	PART NO.	NAME	USED ON
	1	3491	BOLT .....	84 to * — All Models
	2	3787	BOLT (2) .....	84 to * — All Models
	3	4015	SCREW (2) .....	84 to * — All Models
	5	6099	WASHER (2) .....	84 to * — All Models
	6	7036	LOCKWASHER (2) .....	84 to * — All Models
	7	7143	LOCKWASHER .....	84 to * — All Models
	8	7608	NUT .....	84 to * — All Models
	11	7851W	NUT .....	84 to * — All Models
	13	10059	CLAMP, clutch cable .....	84 — FXRS, FXRT
	14	11143	RETAINING RING .....	84 to * — All Models
	17	37098—83	BRACKET, clutch cable .....	84 — FXRS, FXRT
		37098—85	BRACKET, clutch cable .....	85 to * — All Models
	19	38599—83A	CABLE, clutch control — 58.5" .....	84 to * — All Models
	20	38608—82B	BRACKET, hand lever .....	84 to * — All Models
	21	38712—68	CLAMP, clutch cable .....	85 to * — All Models
	22	45017—82A	HAND LEVER .....	84 to * — All Models
	22A	45021—86	SPRING, anti-rattle .....	86 to * — All Models
	23	45032—82	PIVOT PIN .....	84 to * — All Models
	24	45036—82	CABLE ANCHOR PIN .....	84 to * — All Models
	25	45039—68	BUSHING, hand lever anchor pin (2) .....	84 to * — All Models
	26	45044—82	CLAMP, clutch cable clamp .....	84 to * — All Models
	27	90770—79	SCREW .....	86 to * — All Models

**CHAINS AND SPROCKETS**  
**1984 - ALL MODELS;**  
**1986 - FXR**

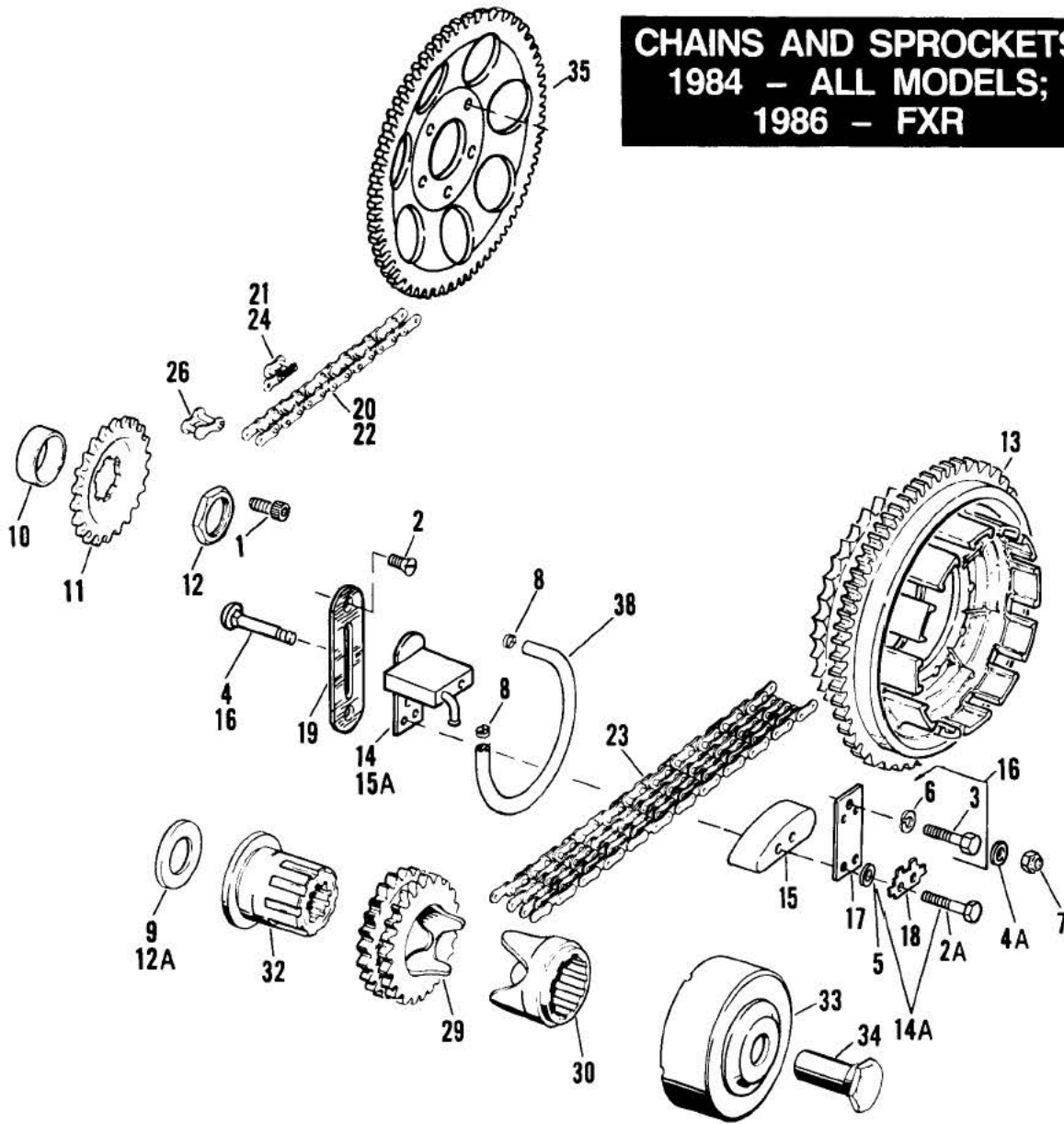

**CHAINS AND SPROCKETS — 1984 — ALL MODELS; 1986 — FXR**

**RS18-1**

RETAIL PRICE	INDEX NO.	PART NO.	NAME	USED ON
	1	857	SCREW	84 — FXRS, FXRT; 86 to * — FXR
	2	1783	SCREW (2)	84 — FXRS, FXRT; 86 to * — FXR
	2A	2614	BOLT (2)	86 to * — FXR
		3862B	BOLT (2)	N/A
	3	4401W	BOLT	84 — FXRS, FXRT
	4	5444	BOLT	84 — FXRS, FXRT; 86 to * — FXR
	4A	6400HB	WASHER	84 — FXRS, FXRT; 86 to * — FXR
	5	6703	WASHER (2)	86 to * — FXR
	6	7038	LOCKWASHER	84 — FXRS, FXRT
	7	7778	NUT	84 — FXRS, FXRT; 86 to * — FXR
	8	10080	CLAMP (2)	Early 84 — FXRS, FXRT

RETAIL PRICE	INDEX NO.	PART NO.	NAME	USED ON
	9	24032-70	SPACER, sprocket shaft — 0.06 thick	84 — FXRS, FXRT; 86 to * — FXR
		24033-70	SPACER, sprocket shaft — 0.09 thick	84 — FXRS, FXRT; 86 to * — FXR
		24034-70	SPACER, sprocket shaft — 0.12 thick	84 — FXRS, FXRT; 86 to * — FXR
		24035-70	SPACER, sprocket shaft — 0.15 thick	84 — FXRS, FXRT; 86 to * — FXR
		24036-70	SPACER, sprocket shaft — 0.18 thick	84 — FXRS, FXRT; 86 to * — FXR
		24037-70	SPACER, sprocket shaft — 0.21 thick	84 — FXRS, FXRT; 86 to * — FXR
	10	33334-79	SPACER, sprocket	84 — FXRS, FXRT
		33347-86	SPACER, sprocket	86 to * — FXR
	11	33336-83	SPROCKET, 22 T - with 857 SCREW	84 — FXRS, FXRT
		33339-86	SPROCKET, 22 T	86 to * — FXR
	12	35211-36	NUT, sprocket	84 — FXRS, FXRT; 86 to * — FXR
	12A	35850-84	SPACER, sprocket shaft — 0.01 thick (as req'd)	Late 84 — FXRS, FXRT; 86 to * — FXR
		35851-84	SPACER, sprocket shaft — 0.02 thick (as req'd)	Late 84 — FXRS, FXRT; 86 to * — FXR
		35852-84	SPACER, sprocket shaft — 0.03 thick (as req'd)	Late 84 — FXRS, FXRT; 86 to * — FXR
	13	37702-70A	CLUTCH SHELL AND SPROCKET, with ring gear	84 — FXRS, FXRT
		37702-84	CLUTCH SHELL AND SPROCKET, with ring gear	Late 84 — FXRS, FXRT
		37707-84	CLUTCH SHELL AND SPROCKET, with ring gear	86 to * — FXR
	14	39951-81	CHAIN TENSIONER SHOE	Early 84 — FXRS, FXRT
	14A	39974-84	TENSIONER SCREW KIT	84 — FXRS, FXRT; 86 to * — FXR
	15	39976-65B	PAD, chain tensioner	84 — FXRS, FXRT; 86 to * — FXR
	15A	39990-65	CHAIN TENSIONER SHOE	Late 84 — FXRS, FXRT; 86 to * — FXR
	16	39992-65C	CHAIN TENSIONER MOUNTING KIT, includes items 4, 4A & 7	84 — FXRS, FXRT; 86 to * — FXR
	17	39993-65	PLATE, chain tensioner	84 — FXRS, FXRT; 86 to * — FXR
	18	39996-65	LOCK PLATE, chain tensioner	84 — FXRS, FXRT; 86 to * — FXR
	19	39998-65	ANCHOR PLATE, chain tensioner	84 — FXRS, FXRT; 86 to * — FXR
	20	40011-84	REAR CHAIN, O-ring — 112 pitch	Late 84 — FXRS, FXRT
		40016-84	REAR CHAIN, O-ring — 110 pitch	86 to * — FXR
	21	40020-84	CONNECTING LINK, O-ring	Late 84 — FXRS, FXRT; 86 to * — FXR
		40026-77	CONNECTING LINK, rear chain (Diamond)	84 — FXRS, FXRT
	22	40028-15E	REAR CHAIN (Duckworth)	84 — FXRT
		40029-15E	REAR CHAIN (Diamond)	84 — FXRT
	23	40037-79	FRONT CHAIN	84 — FXRS, FXRT; 86 to * — FXR
	24	40052-65	CONNECTING LINK, rear chain (Diamond) (press fit)	84 — FXRS, FXRT
		40053-65	CONNECTING LINK, rear chain (Duckworth) (press fit)	84 — FXRS, FXRT
		40055-39	CONNECTING LINK, front chain (Duckworth)	N/A
	26	40091-15	OFFSET REPAIR LINK, rear chain (Diamond)	84 — FXRS, FXRT
	29	40269-85	COMPENSATING SPROCKET, 24 T	86 to * — FXR
		40275-83	COMPENSATING SPROCKET, 24 T	84 — FXRS, FXRT
	30	40299-83	SLIDING CAM	84 — FXRS, FXRT; 86 to * — FXR
	32	40266-85	SHAFT EXTENSION	86 to * — FXR
		40375-70	SHAFT EXTENSION	84 — FXRS, FXRT
	33	40267-85	COVER ASSEMBLY, w/springs	86 to * — FXR
		40384-83A	COVER ASSEMBLY, w/springs	84 — FXRS, FXRT
	34	40392-70	NUT	84 — FXRS, FXRT; 86 to * — FXR
	35	40954-83	SPROCKET, rear wheel — 51 T	84 — FXRS
		41470-86	SPROCKET, rear wheel — 48 T	86 to * — FXR
		41521-83	SPROCKET, rear wheel — 48 T	84 — FXRT
	38	63500-68	NOTE: Hose is sold in bulk length under the following part number. Cut to required length. HOSE, 3/8 I.D. x 5/8" O.D. reinforced rubber (25 ft.)	Early 84 — FXRS, FXRT

# BELTS, CHAINS AND SPROCKETS 1985 & LATER

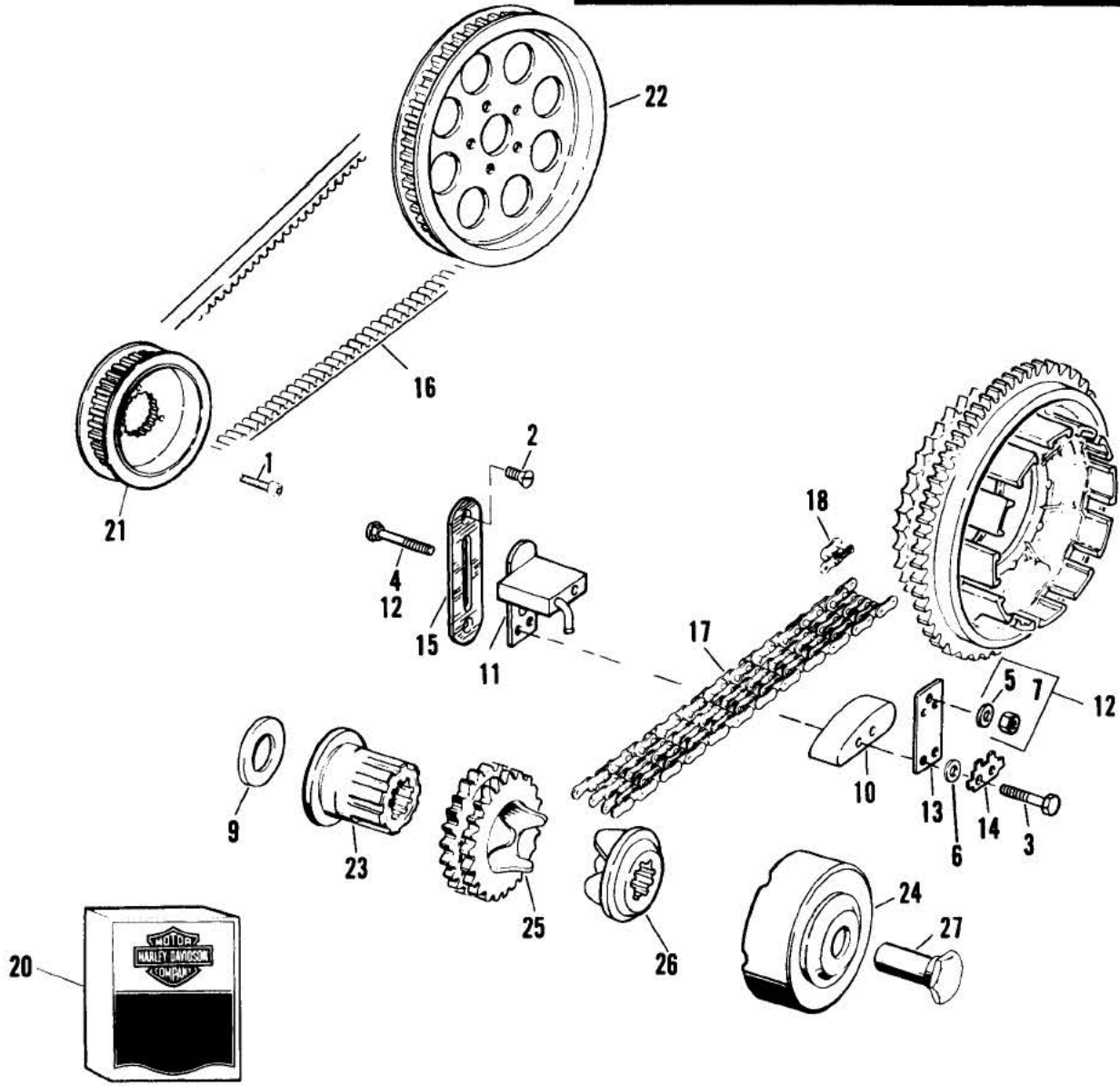



RETAIL PRICE	INDEX NO.	PART NO.	NAME	USED ON
	1	857	SCREW .....	85 to * — FXRS, FXRT; 86 to * — FXRD
	2	1783	SCREW (2) .....	85 to * — FXRS, FXRT; 86 to * — FXRD
	3	2614	BOLT (2) .....	85 to * — FXRS, FXRT; 86 to * — FXRD
	4	5444	BOLT .....	85 to * — FXRS, FXRT; 86 to * — FXRD
	5	6400HB	WASHER .....	85 to * — FXRS, FXRT; 86 to * — FXRD
	6	6703	WASHER (2) .....	85 to * — FXRS, FXRT; 86 to * — FXRD
	7	7778	NUT .....	85 to * — FXRS, FXRT; 86 to * — FXRD
	9	24032—70	SPACER, sprocket shaft — 0.06 thick .....	85 to * — FXRS, FXRT; 86 to * — FXRD
		24033—70	SPACER, sprocket shaft — 0.09 thick .....	85 to * — FXRS, FXRT; 86 to * — FXRD
		24034—70	SPACER, sprocket shaft — 0.12 thick .....	85 to * — FXRS, FXRT; 86 to * — FXRD
		24035—70	SPACER, sprocket shaft — 0.15 thick .....	85 to * — FXRS, FXRT; 86 to * — FXRD
		24036—70	SPACER, sprocket shaft — 0.18 thick .....	85 to * — FXRS, FXRT; 86 to * — FXRD
		24037—70	SPACER, sprocket shaft — 0.21 thick .....	85 to * — FXRS, FXRT; 86 to * — FXRD
		35850—84	SPACER, sprocket shaft — 0.01 thick (as req'd) .....	85 to * — FXRS, FXRT; 86 to * — FXRD
		35851—84	SPACER, sprocket shaft — 0.02 thick (as req'd) .....	85 to * — FXRS, FXRT; 86 to * — FXRD
		35852—84	SPACER, sprocket shaft — 0.03 thick (as req'd) .....	85 to * — FXRS, FXRT; 86 to * — FXRD
	10	39976—65B	PAD, chain tensioner .....	85 to * — FXRS, FXRT; 86 to * — FXRD
	11	39990—65	CHAIN TENSIONER SHOE .....	85 to * — FXRS, FXRT; 86 to * — FXRD
	12	39992—65C	CHAIN TENSIONER MOUNTING KIT, includes items 4, 5 & 7 .....	85 to * — FXRS, FXRT; 86 to * — FXRD
	13	39993—65	PLATE, chain tensioner .....	85 to * — FXRS, FXRT; 86 to * — FXRD
	14	39996—65	LOCKWASHER, chain tensioner plate .....	85 to * — FXRS, FXRT; 86 to * — FXRD
	15	39998—65	ANCHOR PLATE, chain tensioner .....	85 to * — FXRS, FXRT; 86 to * — FXRD
	16	40001—85	REAR BELT, 136 T .....	85 to * — FXRS, FXRT; 86 to * — FXRD
	17	40037—79	FRONT CHAIN .....	85 to * — FXRS, FXRT; 86 to * — FXRD
	18	40055—39	CONNECTING LINK, front chain (Duckworth) .....	N/A
	20	40100—85	REPAIR KIT, belt drive .....	85 to * — FXRS, FXRT; 86 to * — FXRD
	21	40210—85A	SPROCKET, 32 T — belt .....	85 to * — FXRS, FXRT; 86 to * — FXRD
	22	40221—85A	SPROCKET, rear, 70 T — belt (silver) .....	85 to * — FXRS, FXRT; 86 to * — FXRD
	23	40266—85	SHAFT EXTENSION .....	85 to * — FXRS, FXRT; 86 to * — FXRD
	24	40267—85	COVER ASSEMBLY, w/springs .....	85 to * — FXRS, FXRT; 86 to * — FXRD
	25	40269—85	COMPENSATING SPROCKET .....	85 to * — FXRS, FXRT; 86 to * — FXRD
	26	40299—83	SLIDING CAM .....	85 to * — FXRS, FXRT; 86 to * — FXRD
	27	40392—70	NUT .....	85 to * — FXRS, FXRT; 86 to * — FXRD

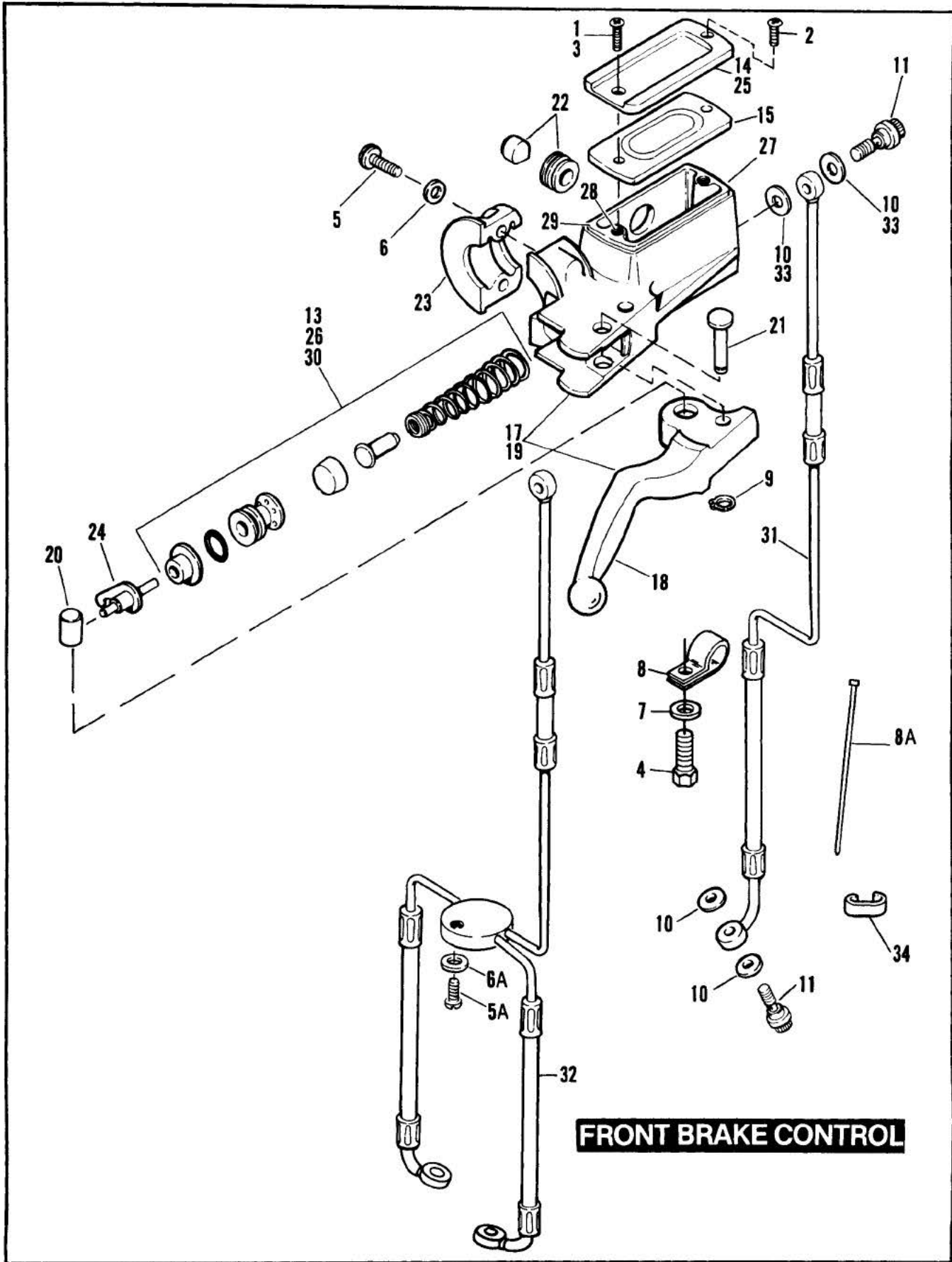

# FRONT BRAKE CONTROL

RS19

RETAIL PRICE	INDEX NO.	PART NO.	NAME	USED ON
	1	2330	SCREW	Early 85 — FXRT
	2	2331	SCREW	Early 85 — FXRT
	3	2579	SCREW (2)	84 to * — FXRS; 84 & Late 85 to * — FXRT; 86 to * — FXR, FXRD
	4	2661W	SCREW	85 to * — All Models
		3444	SCREW	84 to * — FXRS; 84 — FXRT; 86 to * — FXR
	5	4015	SCREW (2)	84 to * — All Models
	5A	4812	SCREW, w/lockpatch	85 to * — FXRT; 86 to * — FXRD
	6	6099	WASHER (2)	84 to * — All Models
	6A	6336B	WASHER	86 to * — FXRT, FXRD
	7	6703	WASHER	84 to * — FXRS; 84 — FXRT; 86 to * — FXR
		7220	LOCKWASHER	85 to * — All Models
	8	10031	CLAMP, brake line	85 to * — All Models
		10053	CLAMP, brake line	84 to * — FXRS; 84 — FXRT; 86 to * — FXR
	8A	10081	CABLE STRAP (2)	Late 85 to * — All Models
	9	11143	RETAINING RING, external	84 to * — All Models
	10	41731—82	GASKET, brake line to caliper (2; 6-dual calipers)	84 to * — All Models
	11	41739—84	FITTING, brake line	84 to * — FXRS; 84 — FXRT; 86 to * — FXR
		41747—82A	FITTING, brake line to caliper (3-dual calipers)	84 to * — All Models
	13	45006—87	REPAIR KIT, master cylinder	Late 85 to * — FXRT; 86 to * — FXRD
	14	45004—85	COVER, master cylinder	Late 85 to * — All Models
	15	45005—85	GASKET, master cylinder cover	Late 85 to * — All Models
		45012—82	GASKET, master cylinder cover	84 & Early 85 — FXRS, FXRT
	17	45013—85	MASTER CYLINDER ASSEMBLY, with hand lever — dual calipers	Late 85 to * — FXRT; 86 to * — FXRD
		45015—83	MASTER CYLINDER ASSEMBLY, with hand lever — dual calipers	Early 85 — FXRT
	18	45016—82	HAND LEVER	84 to * — All Models
	19	45019—85	MASTER CYLINDER ASSEMBLY, with hand lever	84 to * — FXRS; 84 — FXRT; 86 to * — FXR
	20	45031—82	PIN, stoplight switch & push rod	84 to * — All Models
	21	45032—82	PIN, hand lever pivot	84 to * — All Models
	22	45042—82	WINDOW KIT, fluid level	84 to * — All Models
	23	45044—82	CLAMP, master cylinder	84 to * — All Models
	24	45051—82	PUSH ROD, stoplight switch & master cylinder	84 to * — All Models
	25	45057—82	COVER, master cylinder	84 & Early 85 — FXRS, FXRT
	26	45063—82A	REPAIR KIT, master cylinder	Early 85 — FXRT
	27	45065—83	SPACER, reservoir	Early 85 — FXRT
	28	45067—83	SCREW, reservoir spacer (2)	Early 85 — FXRT
	29	45068—83	GASKET, reservoir spacer	Early 85 — FXRT
	30	45072—87	REPAIR KIT, master cylinder	84 to * — FXRS; 84 — FXRT; 86 to * — FXR
	31	45121—88	BRAKE LINE	84 to * — FXRS; 86 to * — FXR
		45128—84	BRAKE LINE	84 — FXRT
	32	45128—85	BRAKE LINE	85 — FXRT
		45128—86	BRAKE LINE	86 to * — FXRT, FXRD
	33	45583—83	GASKET, brake line (2)	84 to * — FXRS; 84 — FXRT; 86 to * — FXR
	34	67239—83	CLAMP, brake line (2)	84 & Early 85 — FXRS, FXRT

# FRONT BRAKE CALIPER

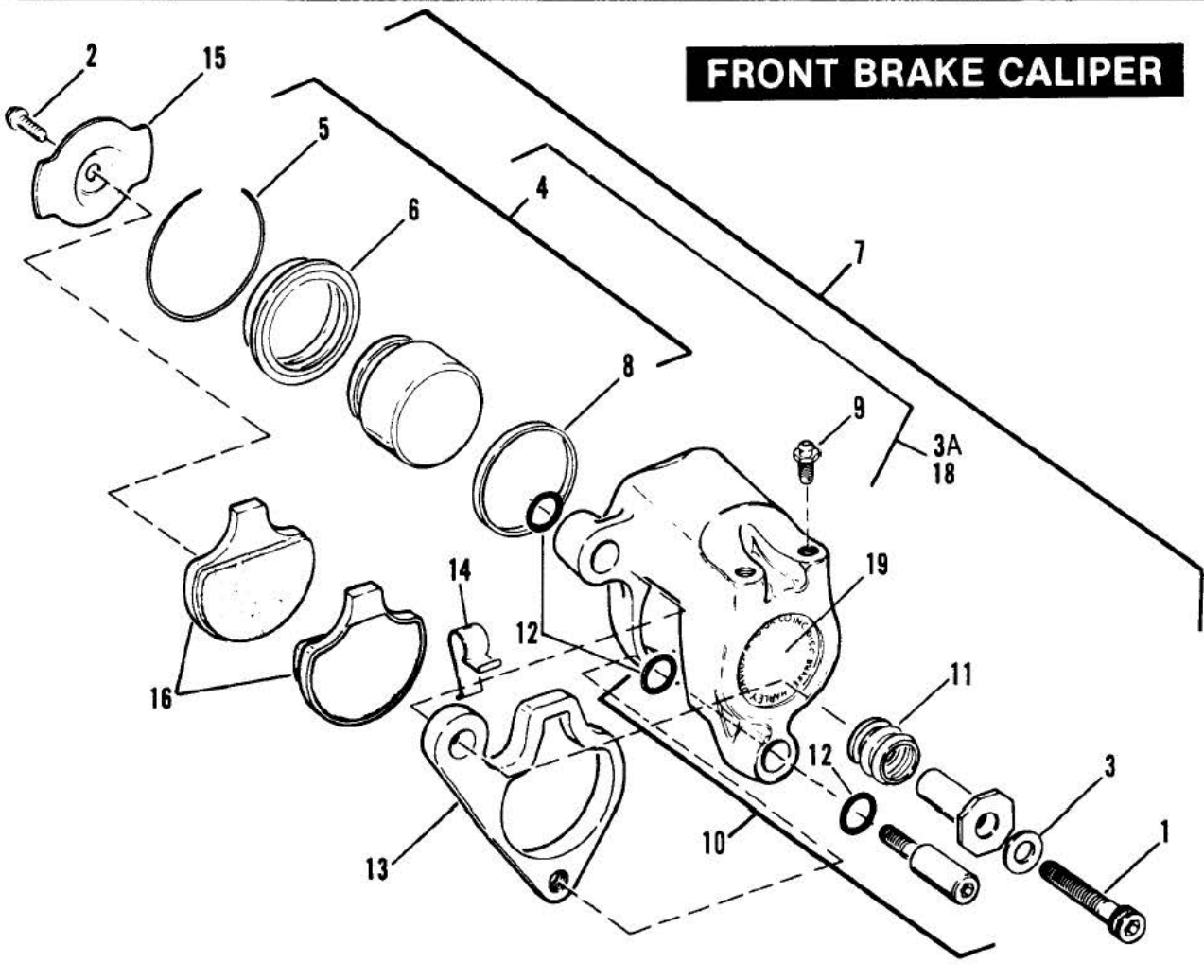

# FRONT BRAKE CALIPER

RS20

RETAIL PRICE	INDEX NO.	PART NO.	NAME	USED ON
	1	855	SCREW (2 — dual calipers)	84 to * — All Models
	2	3517	SCREW (2 — dual calipers)	84 to * — All Models
	3	6019	WASHER (2 — dual calipers)	84 to * — All Models
	3A	44019—83	CALIPER REBUILD KIT, includes items 4 & 9	85 to * — FXRT; 86 to * — FXRD
	4	44020—83	PISTON REBUILD KIT, includes items 5, 6, & 8 (2 — dual calipers)	84 to * — All Models
	5	44021—83	RETAINING RING, piston (2 — dual calipers)	84 to * — All Models
	6	44022—83	DUST BOOT, piston (2 — dual calipers)	84 to * — All Models
	7	44023—83	CALIPER ASSEMBLY, right	85 to * — FXRT; 86 to * — FXRD
		44046—84	CALIPER ASSEMBLY, left	84 to * — All Models
	8	44047—83	SEAL, piston (2 — dual calipers)	84 to * — All Models
	9	44048—83	BLEEDER FITTING (2 — dual calipers)	84 to * — All Models
	10	44053—83A	GUIDE PIN KIT, includes items 11 & 12 (2 — dual calipers)	84 to * — All Models
	11	44054—83	PIN BOOT (2 — dual calipers)	84 to * — All Models
	12	44059—83	O-RING (3; 6 — dual calipers)	84 to * — All Models
	13	44060—83	BRACKET, caliper mounting (2 — dual calipers)	84 to * — All Models
	14	44061—83	SPRING CLIP (2 — dual calipers)	84 to * — All Models
	15	44062—83	RETAINING PAD (2 — dual calipers)	84 to * — All Models
	16	44063—83	PAD SET, includes item 2 (2 — dual calipers)	84 to * — All Models
	18	44065—83	CALIPER REBUILD KIT, includes items 4 & 9	N/A
	19	44197—77	LABEL (2 — dual calipers)	84 to * — FXRS, FXRT

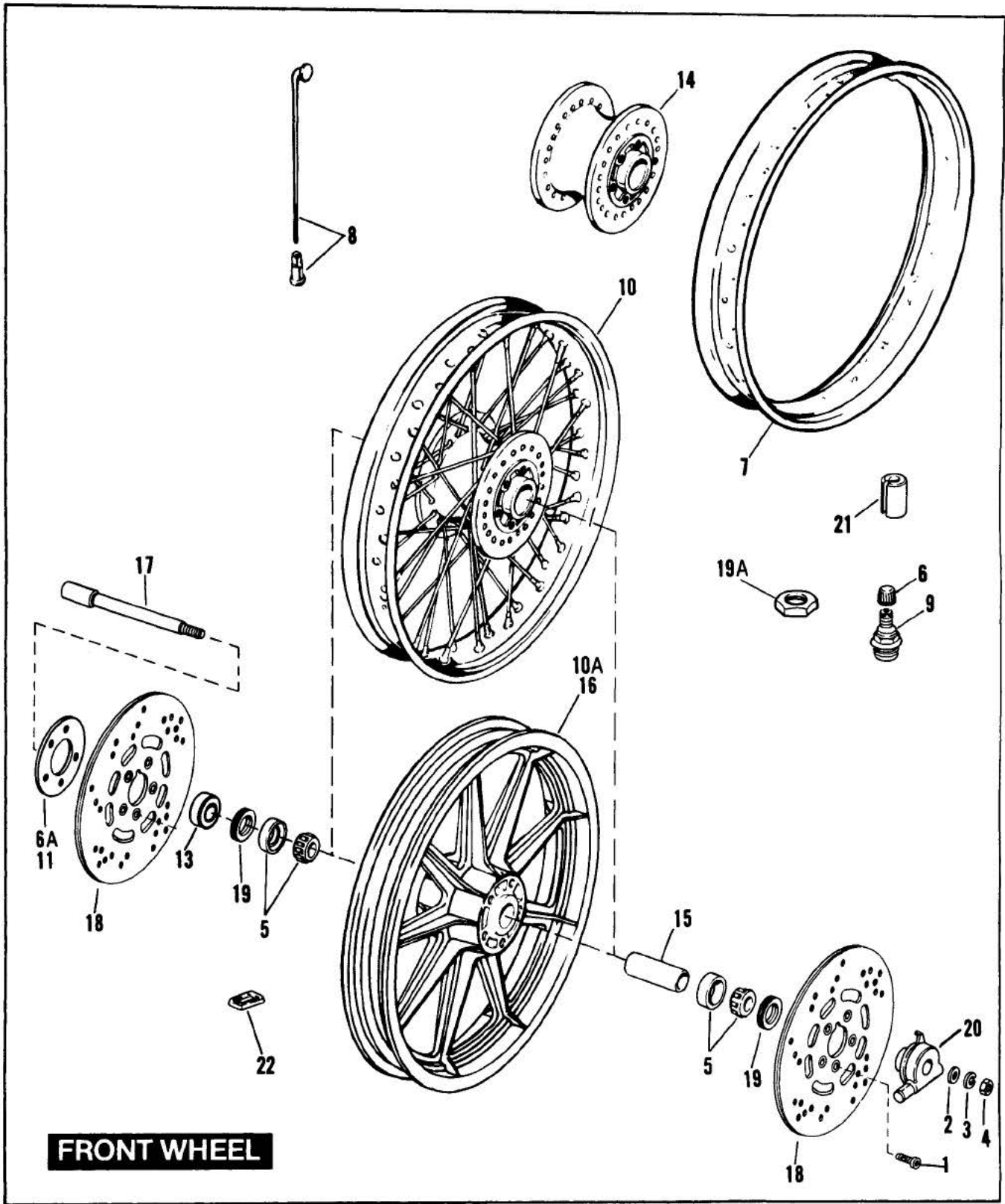

**FRONT WHEEL**

# FRONT WHEEL

RS21

RETAIL PRICE	INDEX NO.	PART NO.	NAME	USED ON
	1	3655	SCREW (10; 5 — FXR, FXRS)	84 to * — All Models
	2	6653	WASHER	84 to * — All Models
	3	7022	LOCKWASHER	84 to * — All Models
	4	7813	NUT	84 to * — All Models
	5	9052	BEARING (2)	84 to * — All Models
	6	41123—79	VALVE CAP	84 to * — All Models
	6A	41814—76A	HUB PLATE	84 — FXRT; 86 to * — FXR
	7	43001—79	RIM, front wheel - 19" (chrome)	84, 86 to * — FXRS
	8	43024—73B	SPOKE AND NIPPLE SET, 19" rim (40; 20 — 1986 & later)	84, 86 to * — FXRS
		43025—73B	SPOKE AND NIPPLE SET, 19" rim (20)	86 to * — FXRS
	9	43150—83	VALVE STEM ASSEMBLY	84 to * — All Models
	10	43312—84	WHEEL ASSEMBLY, laced	84 — FXRS; 86 to * — FXRS
	10A	43338—83	CAST WHEEL ASSEMBLY, 19" w/bearings, seals, & spacers (silver)	84 to * — FXRS
	11	43359—84	HUB PLATE	84 to * — FXRS
	13	43358—83A	SPACER, bearing	84 to * — All Models
	14	43619—84	HUB, with bearings & seals	84, 86 to * — FXRS
	15	43623—78	SLEEVE, between bearings 2.564" (violet)	84 to * — All Models
		43624—78	SLEEVE, between bearings 2.550" (pink)	84 to * — All Models
		43625—78	SLEEVE, between bearings 2.536" (gold)	84 to * — All Models
	16	43626—84	CAST WHEEL ASSEMBLY, 19" w/bearings, seals & spacers (black)	84 to * — FXRT; 85 — FXRS; 86 to * — FXR, FXRD
	17	43883—84	AXLE, front	84 to * — All Models
	18	44136—84A	DISC, brake (2 — dual calipers)	84 to * — All Models
	19	47519—83A	OIL SEAL (2)	84 to * — All Models
	19A	54321—85	NUT, valve stem	84, 86 to * — All Models
	20	67127—84A	DRIVE, speedometer	84 to * — All Models
	21	95578—41	WEIGHT, 0.50 oz. (for laced wheel)	84, 86 to * — FXRS
		95581—47	WEIGHT, 0.75 oz. (for laced wheel)	84, 86 to * — FXRS
		95582—47	WEIGHT, 1.0 oz. (for laced wheel)	84, 86 to * — FXRS
	22	95594—84	WEIGHT, 0.25 oz. (for cast wheel)(black)	84 & 85 — FXRS, FXRT; 86 to * — FXR, FXRT, FXRD
		95595—84	WEIGHT, 0.25 oz. (for cast wheel)(silver)	86 to * — FXRS

# REAR BRAKE CONTROL

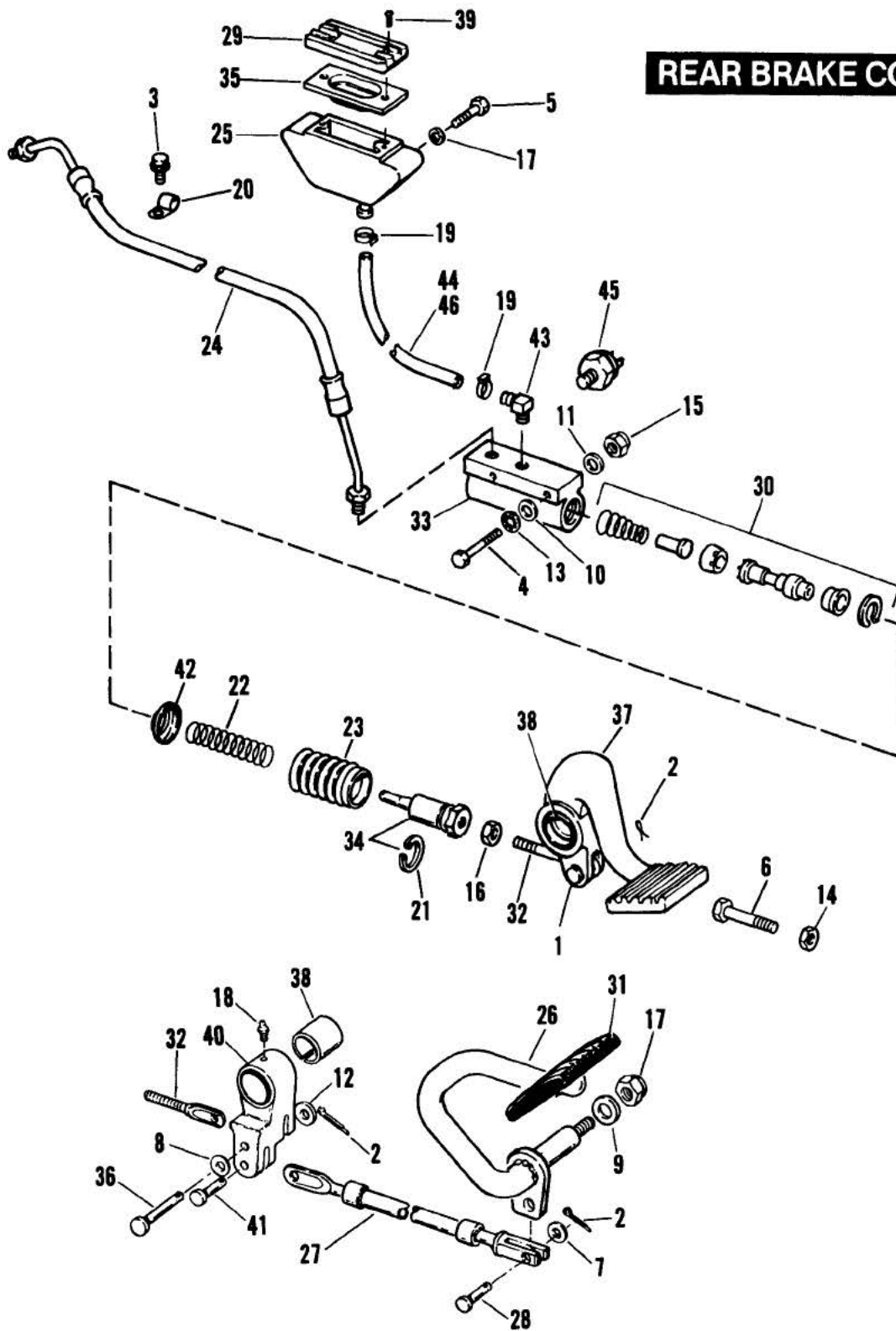



# REAR BRAKE CONTROL

RS22

RETAIL PRICE	INDEX NO.	PART NO.	NAME	USED ON
	1	222	CLEVIS PIN .....	84 to * — FXRS, FXRT; 86 to * — FXR
	2	515	COTTER PIN (3 — FXRD) .....	84 to * — All Models
	3	2501	SCREW .....	84 to * — All Models
	4	2887W	BOLT (2) .....	84 to * — All Models
	5	3473	BOLT (2) .....	84 to * — All Models
	6	3802W	SCREW, lever stop .....	84 to * — All Models
	7	6220W	WASHER .....	86 to * — FXRD
	8	6317	WASHER (2) .....	86 to * — FXRD
	9	6516HW	WASHER .....	86 to * — FXRD
	10	6702	WASHER (4) .....	Late 84 to * — All Models
	11	6716	WASHER (2) .....	84 to * — All Models
	12	6730	WASHER .....	86 to * — FXRD
	13	7127	LOCKWASHER (2) .....	Early 84 — FXRS, FXRT
	14	7689W	NUT .....	84 to * — FXRS, FXRT; 86 to * — FXR
	15	7740	LOCKNUT (2) .....	Late 84 to * — All Models
	16	7744	NUT .....	84 to * — All Models
	17	7825	LOCKNUT .....	86 to * — FXRD
	18	9851	GREASE FITTING .....	86 to * — FXRD
	19	10038	CLAMP (2) .....	84 to * — All Models
	20	38712—68	CLAMP .....	84 to * — All Models
	21	40918—82	RETAINING RING .....	84 to * — All Models
	22	40920—82	SPRING, brake return .....	84 to * — All Models
	23	40922—79	BOOT, master cylinder .....	84 to * — All Models
	24	40956—82	HOSE, rear brake .....	84 to * — All Models
	25	41800—81A	RESERVOIR, master cylinder .....	84 to * — All Models
		41804—84A	RESERVOIR, master cylinder (HDI part only) .....	86 to * — All Models
	26	42240—85	BRAKE PEDAL .....	86 to * — FXRD
	27	42256—85	BRAKE ROD .....	86 to * — FXRD
	28	42269—30	CLEVIS PIN .....	86 to * — FXRD
	29	42376—77A	COVER, master cylinder reservoir .....	84 to * — All Models
	30	42382—82A	REPAIR KIT, master cylinder .....	84 to * — All Models
	31	42416—83	PAD, brake pedal .....	86 to * — FXRD
	32	42437—81	ROD END .....	84 to * — All Models
	33	42446—82A	MASTER CYLINDER, rear .....	84 to * — All Models
	34	42448—82A	PLUNGER, brake, with retaining ring .....	84 to * — All Models
	35	42455—80	GASKET, master cylinder .....	84 to * — All Models
	36	42460—80A	CLEVIS PIN .....	86 to * — FXRD
	37	42523—82	BRAKE PEDAL ASSEMBLY, includes items 1, 2, 32 & 38 .....	84 to * — FXRS, FXRT; 86 to * — FXR
	38	42524—82	BUSHING (2) .....	84 to * — All Models
	39	42534—82	SCREW (2) .....	84 to * — All Models
	40	42535—85A	PIVOT, brake pedal, includes items 18 & 38 .....	86 to * — FXRD
	41	42538—85	CLEVIS PIN .....	86 to * — FXRD
	42	44126—82	WASHER, brake return spring .....	84 to * — All Models
	43	63551—82	FITTING, reservoir hose .....	84 to * — All Models
	44	63561—84	HOSE, reservoir to master cylinder .....	Late 84 to * — All Models
	45	72023—51A	STOPLIGHT SWITCH .....	84 to * — All Models

NOTE: Hose is sold only in bulk under the following part number. Cut to required lengths.

46	63500—68	HOSE, 3/8 I.D. x 5/8 O.D. reinforced rubber (25 ft. lg.)	Early 84 — FXRS, FXRT
----	----------	--	-----------------------

# REAR BRAKE CALIPER

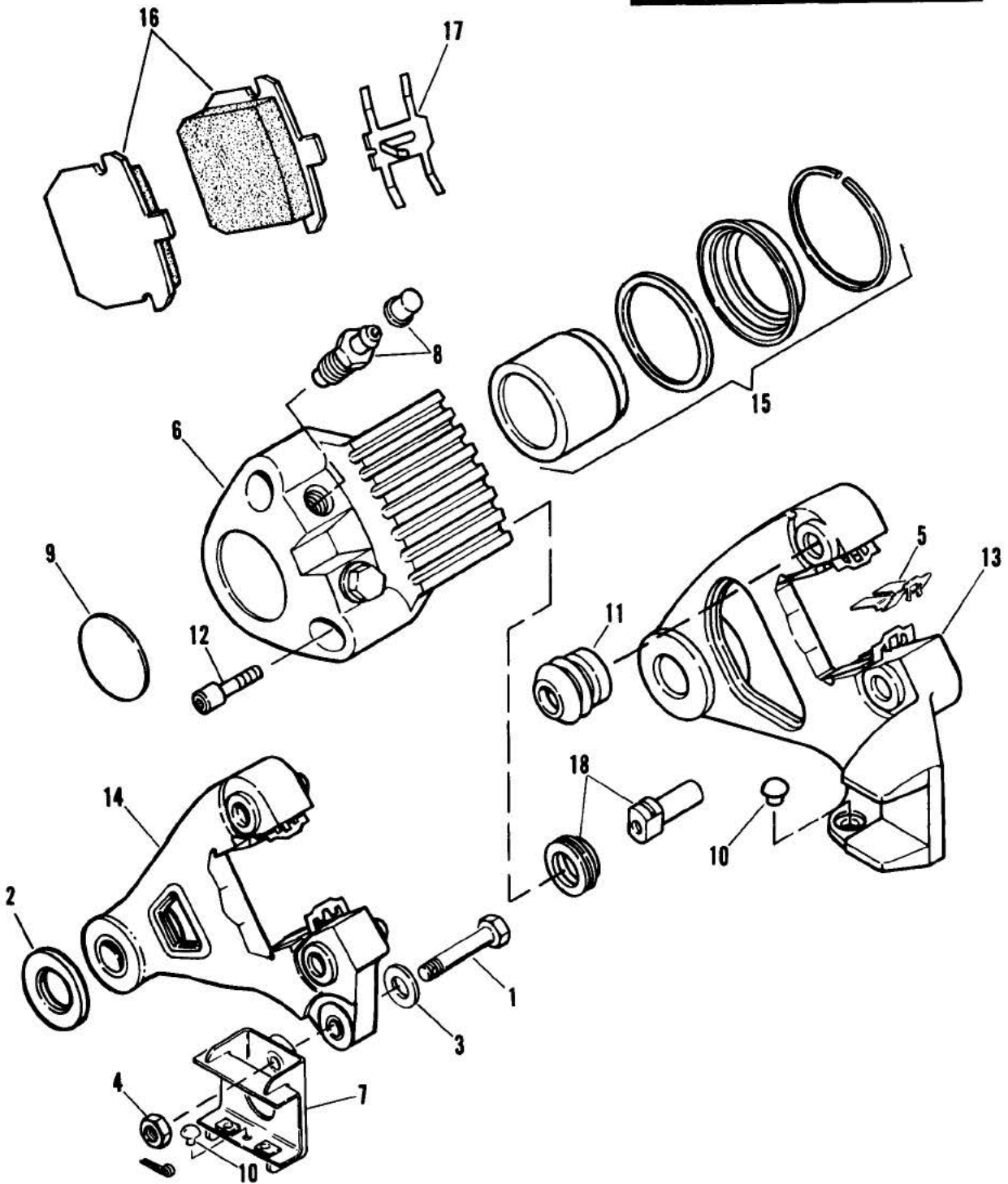

# REAR BRAKE CALIPER

RS23

RETAIL PRICE	INDEX NO.	PART NO.	NAME	USED ON
	1	3496	BOLT	84 — FXRS, FXRT
	2	5738	SPACER	84 — FXRT
	3	6416	WASHER	84 — FXRS, FXRT
	4	7610	LOCKNUT	84 — FXRS, FXRT
	5	41665—82	SHIM (2)	84 to * — All Models
	6	44050—82A	BODY ASSEMBLY, includes items 8, 15 & 17	84 to * — All Models
	7	44055—83	BRACKET	84 — FXRS, FXRT
	8	44146—82	BLEED SCREW & DUST COVER	84 to * — All Models
	9	44197—77	LABEL	84 to * — All Models
	10	44199—82	RUBBER BUMPER	84 to * — All Models
	11	44200—82	PIN BOOT (2)	84 to * — All Models
	12	44201—82	BOLT, mounting (2)	84 to * — All Models
	13	44205—82	BRACKET, mounting — includes items 5, 10 & 18	84 to * — FXRS, 85 to * — FXRT; 86 to * — FXR, FXRD
	14	44207—82	BRACKET, mounting — includes items 5 & 18	84 — FXRT
	15	44208—82	REPAIR KIT	84 to * — All Models
	16	44209—82	PAD SET	84 to * — All Models
	17	44211—82	PAD SPRING	84 to * — All Models
	18	44212—82	GUIDE PIN KIT, includes items 11 & 12	84 to * — All Models

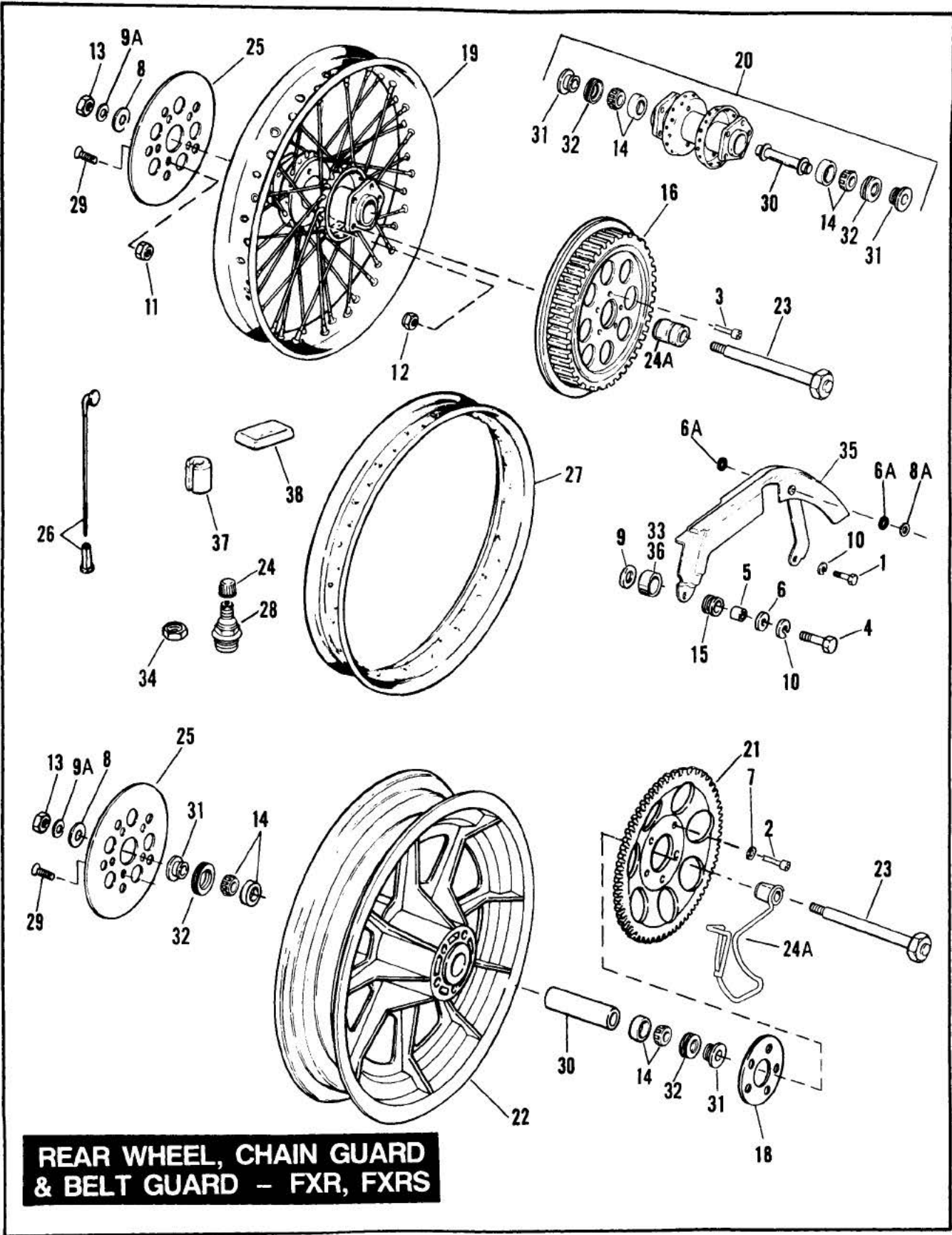

**REAR WHEEL, CHAIN GUARD  
& BELT GUARD - FXR, FXRS**

**REAR WHEEL, CHAIN GUARD & BELT GUARD — FXR, FXRS**

**RS24-1**

RETAIL PRICE	INDEX NO.	PART NO.	NAME	USED ON
	1	2698	SCREW .....	84 to * — FXRS; 86 to * — FXR
	2	3771	SCREW (for cast wheel)(5) .....	84 to * — FXRS; 86 to * — FXR
	3	3782	SCREW (for laced wheel)(5) .....	84 — FXRS
		4726	BOLT (for laced wheel)(5) .....	86 to * — FXRS
	4	4014W	BOLT .....	84 to * — FXRS; 86 to * — FXR
	5	5926B	SPACER .....	84 to * — FXRS; 86 to * — FXR
	6	6107B	WASHER .....	84 to * — FXRS; 86 to * — FXR
	6A	6398	WASHER (rubber)(2) .....	86 to * — FXR
	7	6516HW	WASHER (5) .....	84 to * — FXRS
	8	6655	WASHER .....	84 to * — FXRS; 86 to * — FXR
	8A	6701	WASHER .....	86 to * — FXR
	9	6702	WASHER .....	85 to * — FXRS
	9A	7022	LOCKWASHER .....	84 to * — FXRS; 86 to * — FXR
	10	7041	LOCKWASHER (2) .....	84 to * — FXRS; 86 to * — FXR
	11	7778	LOCKNUT (for laced wheel)(5) .....	84, 86 to * — FXRS
	12	7561	LOCKNUT (for laced wheel)(5) .....	86 to * — FXRS
		7827W	LOCKNUT (for laced wheel)(5) .....	84 — FXRS
	13	7986	NUT .....	84 to * — FXRS; 86 to * — FXR
	14	9052	BEARING, complete (2) .....	84 to * — FXRS; 86 to * — FXR
	15	11411	GROMMET .....	84 to * — FXRS; 86 to * — FXR
	16	40221—85A	SPROCKET, 70 T, belt .....	85 to * — FXRS; 86 to * — FXR
	18	40932—81	SPACER, rear sprocket .....	85 — FXRS; 86 to * — FXR
	19	40951—82	LACED WHEEL ASSEMBLY, with bearings .....	84 — FXRS
		40975—86	LACED WHEEL ASSEMBLY, with bearings .....	86 to * — FXRS
	20	40952—82A	HUB ASSEMBLY, laced wheel, with spacer .....	84 — FXRS
		40976—86	HUB ASSEMBLY, laced wheel, with spacer .....	86 to * — FXRS
	21	40954—83	SPROCKET, 51 T .....	84 — FXRS
		41470—86	SPROCKET, 48 T .....	86 to * — FXR
	22	40983—83A	CAST WHEEL ASSEMBLY, with bearings (silver) .....	84 & 85 — FXRS
		40983—86	CAST WHEEL ASSEMBLY, with bearings (silver) .....	86 to * — FXRS
		41015—82A	CAST WHEEL ASSEMBLY, with bearings (black) .....	84 & 85 — FXRS
		41015—86	CAST WHEEL ASSEMBLY, with bearings (black) .....	86 to * — FXR
	23	41110—79	AXLE .....	84 to * — FXRS; 86 to * — FXR
	24	41123—79	VALVE CAP .....	84 to * — FXRS; 86 to * — FXR
	24A	41591—81	SPACER, rear axle — sprocket side .....	85 to * — FXRS
		41591—84	DEBRIS DEFLECTOR .....	84 — FXRS; 86 to * — FXR
	25	41791—79A	DISC, rear brake .....	84 to * — FXRS; 86 to * — FXR
	26	43032—40B	SPOKE AND NIPPLE SET, 16" rim (40) .....	84, 86 to * — FXRS
	27	43085—81	RIM, 16" (chrome) .....	84, 86 to * — FXRS
	28	43157—83A	VALVE STEM ASSEMBLY (for cast wheel) .....	84 to * — FXRS; 86 to * — FXR
	29	43567—79	SCREW (5) .....	84 to * — FXRS; 86 to * — FXR
	30	43601—78A	SPACER, with flanges — 4.420 (laced wheel)(orange) ..	86 to * — FXRS
		43602—78A	SPACER, with flanges — 4.434 (laced wheel)(yellow) ..	86 to * — FXRS
		43603—78A	SPACER, with flanges — 4.448 (laced wheel)(white) ...	86 to * — FXRS
		43604—78	SPACER, 4.420 (orange) .....	84 to * — FXRS; 86 to * — FXR
		43605—78	SPACER, 4.434 (yellow) .....	84 to * — FXRS; 86 to * — FXR
		43606—78	SPACER, 4.448 (white) .....	84 to * — FXRS; 86 to * — FXR
	31	43654—86A	SPACER (2) .....	84 to * — FXRS; 86 to * — FXR

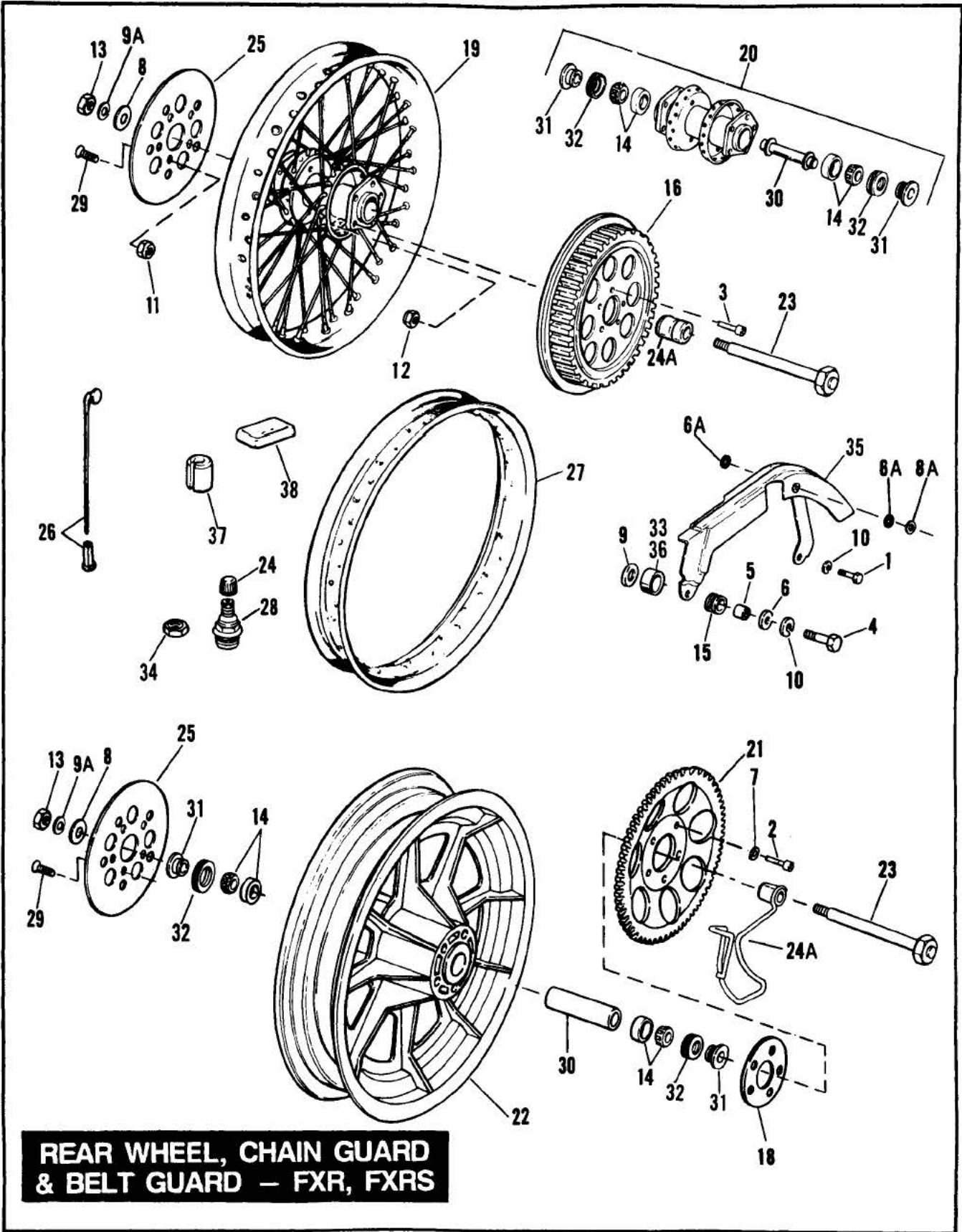

**REAR WHEEL, CHAIN GUARD & BELT GUARD — FXR, FXRS (CONT'D)**

**RS24-2**

RETAIL PRICE	INDEX NO.	PART NO.	NAME	USED ON
	32	47519-83A	OIL SEAL (2) .....	84 to * — FXRS; 86 to * — FXR
	33	52103-31	SPACER .....	86 to * — FXR
	34	54321-85	NUT, valve stem .....	84, 85 to * — FXRS
	35	60299-85	BELT GUARD .....	85 to * — FXRS
		60607-81A	CHAIN GUARD (chrome) .....	84 — FXRS
		60640-86	CHAIN GUARD .....	86 to * — FXR
	36	61135-57	SPACER .....	84 — FXRS
	37	95581-47	WHEEL WEIGHT, 0.75 oz. (for laced wheel) .....	84 — FXRS; 86 to * — FXR
		95582-47	WHEEL WEIGHT, 1.0 oz. (for laced wheel) .....	84 — FXRS; 86 to * — FXR
	38	95594-84	WHEEL WEIGHT, 0.25 oz. (black) .....	84 to * — FXRS; 86 to * — FXR
		95595-84	WHEEL WEIGHT, 0.25 oz. (silver) .....	84 & 85 — FXRS; 86 to * — FXR

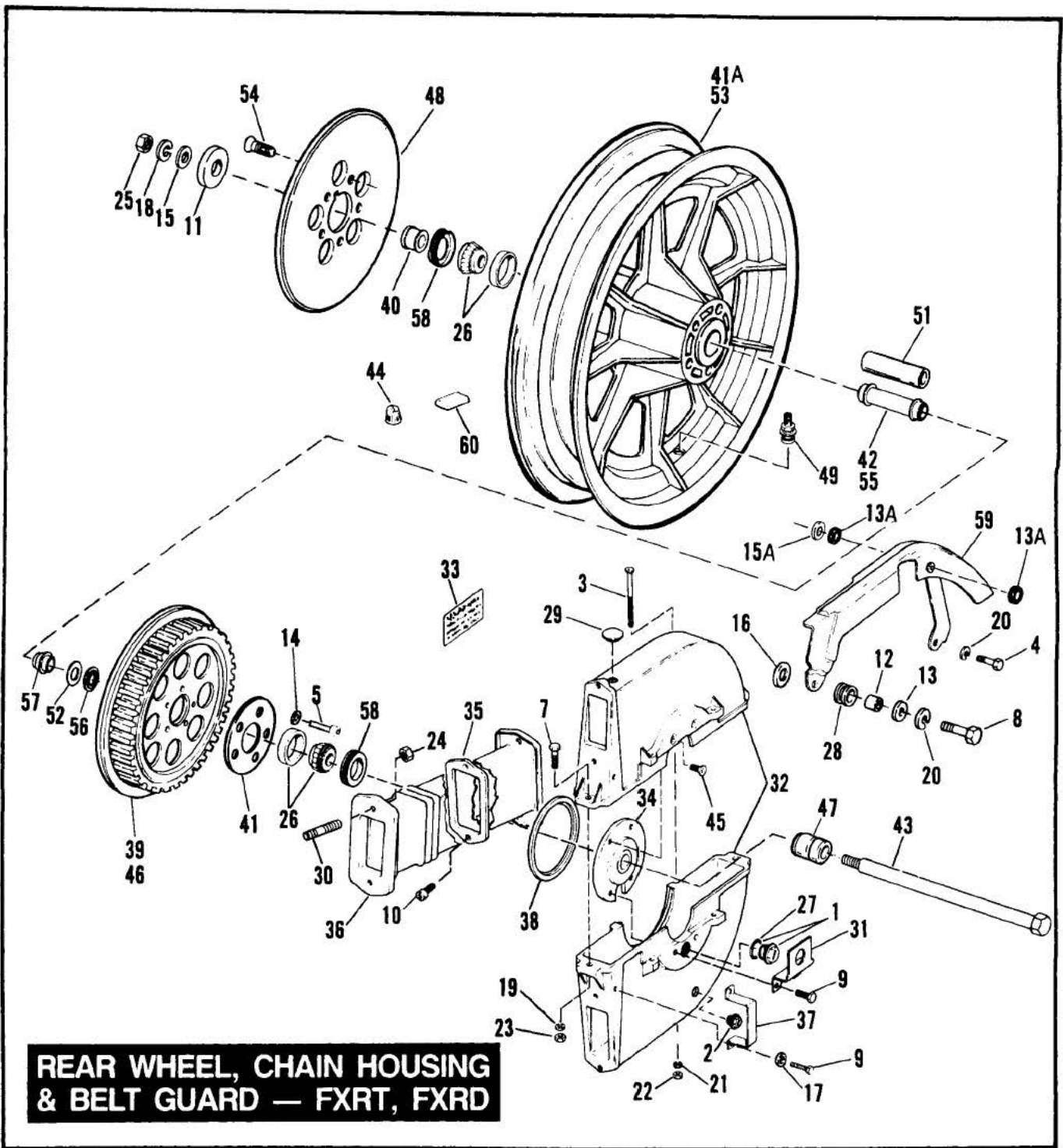

**REAR WHEEL, CHAIN HOUSING & BELT GUARD — FXRT, FXRD**

**RS24A-1**

RETAIL PRICE	INDEX NO.	PART NO.	NAME	USED ON
	1	708A	PLUG, with O-ring .....	84 — FXRT
	2	717	PLUG, with O-ring .....	84 — FXRT
	3	2002	SCREW (2) .....	84 — FXRT
	4	2698	SCREW .....	85 to * — FXRT; 86 to * — FXRD
	5	3542	SCREW (5) .....	84 — FXRT
		3771	BOLT (5) .....	85 to * — FXRT; 86 to * — FXRD
	7	3825	BOLT (2) .....	84 — FXRT
	8	4014W	BOLT .....	85 to * — FXRT; 86 to * — FXRD
	9	4702	BOLT (4) .....	84 — FXRT



RETAIL PRICE	INDEX NO.	PART NO.	NAME	USED ON
	10	4812	SCREW (7)	84 — FXRT
	11	5738	SPACER	84 — FXRT
	12	5926B	SPACER	85 to * — FXRT; 86 to * — FXRD
	13	6107B	WASHER	85 to * — FXRT; 86 to * — FXRD
	13A	6398	WASHER (2)	85 to * — FXRT; 86 to * — FXRD
	14	6516HW	WASHER (5)	85 to * — FXRT; 86 to * — FXRD
	15	6655	WASHER	84 to * — FXRT; 86 to * — FXRD
	15A	6701	WASHER	85 to * — FXRT; 86 to * — FXRD
	16	6702	WASHER	85 to * — FXRT; 86 to * — FXRD
	17	6703	WASHER (4)	84 — FXRT
	18	7022	LOCKWASHER	84 to * — FXRT; 86 to * — FXRD
	19	7036	LOCKWASHER (2)	84 — FXRT
	20	7041	LOCKWASHER (2)	85 to * — FXRT; 86 to * — FXRD
	21	7069	LOCKWASHER (2)	84 — FXRT
	22	7620W	NUT (2)	84 — FXRT
	23	7676	NUT (2)	84 — FXRT
	24	7742	LOCKNUT	84 — FXRT
	25	7986	NUT	84 to * — FXRT; 86 to * — FXRD
	26	9052	ROLLER BEARING (2)	84 to * — FXRT; 86 to * — FXRD
	27	11115	O-RING	84 — FXRT
	28	11411	GROMMET	85 to * — FXRT; 86 to * — FXRD
	29	11428	PLUG, chain housing fill	84 — FXRT
	30	11726	STUD, chain boot	N/A 84 — FXRT
	31	25402—79A	BRACKET, rear	84 — FXRT
	32	25403—82A	CHAIN COVER ASSEMBLY, includes items 3, 7, 19 & 21-23	84 — FXRT
	33	25404—80	DECAL, "WARNING — TORQUE WHEEL BOLTS," etc.	84 — FXRT
	34	25410—79A	SPACER PLATE	84 — FXRT
	35	25411—79	PLATE, boot mounting (4)	84 — FXRT
	36	25412—79	BOOT, chain (2)	84 — FXRT
	37	25413—79	BRACKET, front	84 — FXRT
	38	25414—82	SEAL	84 — FXRT
	39	40221—85A	SPROCKET, 70 T, (belt)	85 to * — FXRT; 86 to * — FXRD
	40	43654—86A	SPACER, right (2 — 85)	84 — FXRT; 86 to * — FXRD
	41	40932—81	SPACER, sprocket	85 — FXRT
	41A	41015—82A	CAST WHEEL ASSEMBLY, w/bearings (black)	85 to * — FXRT
		41015—86	CAST WHEEL ASSEMBLY, w/bearings (black)	86 to * — FXRT, FXRD
	42	41087—83	SPACER, between bearings	84 — FXRT
	43	41110—79	AXLE	84 to * — FXRT; 86 to * — FXRD
	44	41123—79	VALVE CAP	84 to * — FXRT; 86 to * — FXRD
	45	41191—74	SCREW, ctsk. flat socket hd. (2)	84 — FXRT
	46	41521—83	SPROCKET, only — 48 T	84 — FXRT
	47	41591—81	SPACER, rear axle — sprocket side	85 to * — FXRT; 86 to * — FXRD
	48	41791—79A	DISC, rear brake	84 to * — FXRT; 86 to * — FXRD
	49	43157—83A	VALVE STEM ASSEMBLY	84 to * — FXRT; 86 to * — FXRD
	51	43287—83	SLEEVE	84 — FXRT
	52	43290—82	SPACER, 0.032 thick	84 — FXRT
		43291—82	SPACER, 0.016 thick	84 — FXRT
		43292—82	SPACER, 0.008 thick	84 — FXRT
		43293—82	SPACER, 0.004 thick	84 — FXRT
		43294—82	SPACER, 0.002 thick	84 — FXRT
	53	43310—83	CAST WHEEL ASSEMBLY, w/bearings (black)	84 — FXRT
	54	43567—79	SCREW (5)	84 to * — FXRT; 86 to * — FXRD
	55	43604—78	SPACER, between bearings — 4.420 (orange)	85 to * — FXRT; 86 to * — FXRD
		43605—78	SPACER, between bearings — 4.434 (yellow)	85 to * — FXRT; 86 to * — FXRD
		43606—78	SPACER, between bearings — 4.448 (white)	85 to * — FXRT; 86 to * — FXRD
	56	43650—82	SPACER WASHER	84 — FXRT
	57	43667—82	SPACER, left	84 — FXRT
	58	47519—83A	OIL SEAL (2)	84 to * — FXRT; 86 to * — FXRD
	59	60299—85	BELT GUARD	85 to * — FXRT; 86 to * — FXRD
	60	95594—84	WHEEL WEIGHT, 0.25 oz. (black)	84 & 85 — FXRT; 86 to * — FXRD

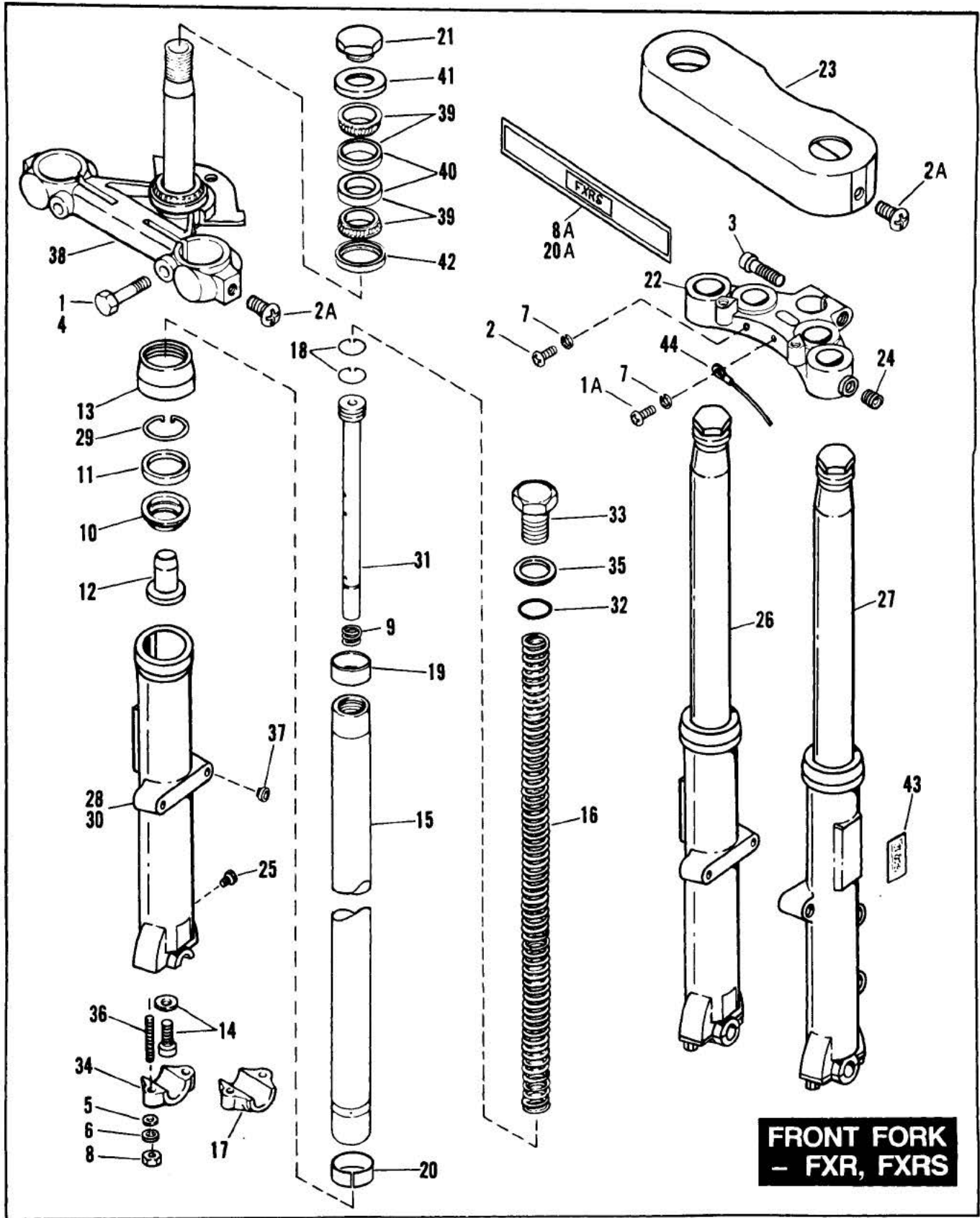

**FRONT FORK  
- FXR, FXRS**

RETAIL PRICE	INDEX NO.	PART NO.	NAME	USED ON
	1	854	SCREW (2)	86 to * — FXR
	1A	2661W	SCREW	85 to * — FXRS; 86 to * — FXR
	2	2662W	SCREW (2 — 84)	84 to * — FXRS; 86 to * — FXR
	2A	2823	SCREW (4)	84 to * — FXRS
	3	4371W	BOLT	84 to * — FXRS; 86 to * — FXR
	4	4411	BOLT (2)	84 to * — FXRS
	5	6702	WASHER (4)	84 to * — FXRS; 86 to * — FXR
	6	7041	LOCKWASHER (4)	84 to * — FXRS; 86 to * — FXR
	7	7220	LOCKWASHER (2)	84 to * — FXRS; 86 to * — FXR
	8	7748W	NUT (4)	84 to * — FXRS; 86 to * — FXR
	8A	14050—86	NAMEPLATE "Liberty"	86 to * — FXRS
	9	45382—83	SPRING, slider (2)	84 to * — FXRS; 86 to * — FXR
	10	45386—83	SPACER, seal (2)	84 to * — FXRS; 86 to * — FXR
	11	45387—83	OIL SEAL, slider (2)	84 to * — FXRS; 86 to * — FXR
	12	45403—84	LOWER STOP (2)	84 to * — FXRS; 86 to * — FXR
	13	45404—75	DUST COVER (2)	84 to * — FXRS; 86 to * — FXR
	14	45405—75A	SCREW WITH WASHER, damper tube (2)	84 to * — FXRS; 86 to * — FXR
	15	45407—83	SLIDER TUBE (2)	84 to Early 86 — FXRS; Early 86 — FXR
		45407—86	SLIDER TUBE (2)	Late 86 to * — FXR, FXRS
	16	45408—84	SPRING (2)	84 to * — FXRS; 86 to * — FXR
	17	45410—84	AXLE CAP, left slider	84 to * — FXRS; 86 to * — FXR
	18	45412—75	RING, damper tube (4)	84 to * — FXRS; 86 to * — FXR
	19	45413—84	BUSHING, upper - fork slider (2)	84 to * — FXRS; 86 to * — FXR
	20	45416—84	BUSHING, lower - fork slider (2)	84 to * — FXRS; 86 to * — FXR
	20A	45429—84	NAMEPLATE "FXRS"	84 & 85 — FXRS
		45429—86	NAMEPLATE "Low Rider®"	86 to * — FXRS
	21	45718—71	NUT, fork stem	84 to * — FXRS; 86 to * — FXR
	22	45736—78B	BRACKET, upper	84 to * — FXRS; 86 to * — FXR
		45743—84	BRACKET, lower (HDI part only)	86 to * — FXR
		45746—84	BRACKET, lower (HDI part only)	86 to * — FXRS
	23	45751—71A	COVER, fork	84 to * — FXRS
	24	45782—72A	SCREW INSERT (2)	84 to * — FXRS
	25	45790—80	DRAIN SCREW, slider (2)	84 to * — FXRS; 86 to * — FXR
	26	45903—84A	FORK SLIDER & TUBE ASSEMBLY, right	84 to * — FXRS; 86 to * — FXR
	27	45904—84A	FORK SLIDER & TUBE ASSEMBLY, left	84 to * — FXRS; 86 to * — FXR
	28	45906—84	SLIDER, right	84 to * — FXRS; 86 to * — FXR
	29	45908—80	RETAINING RING, oil seal (2)	84 to * — FXRS; 86 to * — FXR
	30	45912—84	SLIDER, left	84 to * — FXRS; 86 to * — FXR
	31	45914—84	DAMPER TUBE, complete (2)	84 to * — FXRS; 86 to * — FXR
	32	45982—73	O-RING, slider tube cap (2)	84 to * — FXRS; 86 to * — FXR
	33	45993—73	CAP, slider tube (2)	84 to Early 86 — FXRS; Early 86 — FXR
		45993—86	CAP, slider tube (2)	Late 86 to * — FXR, FXRS
	34	45994—84	AXLE CAP, right slider	84 to * — FXRS; 86 to * — FXR
	35	45997—73	WASHER, slider tube cap (2)	84 to * — FXRS; 86 to * — FXR
	36	45998—73	STUD (4)	84 to * — FXRS; 86 to * — FXR
	37	46020—84	BUSHING, brake caliper — left slider	84 to * — FXRS; 86 to * — FXR
	38	47693—84	BRACKET, lower - w/bearing and shield	84 to * — FXRS
		47694—84	BRACKET, lower - w/bearing and shield	86 to * — FXR
		48140—84	TUMBLER, fork lock (HDI part only)	86 to * — FXR, FXRS
	39	48300—60	ROLLER BEARING, w/cup (2)	84 to * — FXRS; 86 to * — FXR
	40	48315—60	BEARING CUP (2)	84 to * — FXRS; 86 to * — FXR
	41	48361—80	DUST SHIELD, head bearing - upper	84 to * — FXRS; 86 to * — FXR
	42	48365—48A	DUST SHIELD, head bearing - lower	84 to * — FXRS; 86 to * — FXR
	43	59254—72	REFLECTOR (amber) (2)	84 to * — FXRS; 86 to * — FXR
	44	70191—73A	CABLE	84 to * — FXRS; 86 to * — FXR

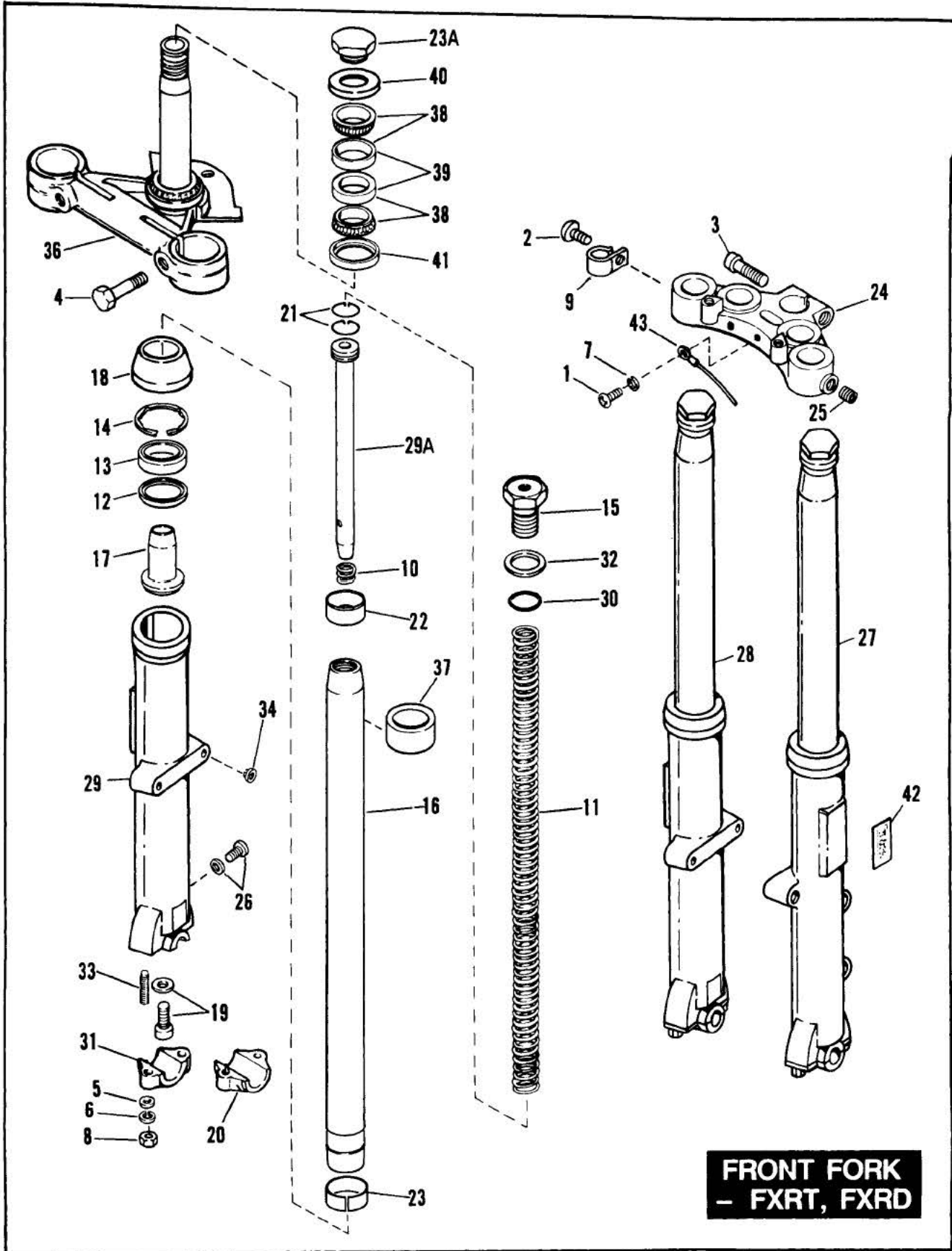

RETAIL PRICE	INDEX NO.	PART NO.	NAME	USED ON
	1	2661W	SCREW (2)	85 to * — FXRT; 86 to * — FXRD
		2662W	SCREW (2)	84 — FXRT
	2	2823	SCREW	84 — FXRT
	3	4371W	BOLT	84 to * — FXRT; 86 to * — FXRD
	4	4411	BOLT (2)	84 to * — FXRT; 86 to * — FXRD
	5	6702	WASHER (4)	84 to * — FXRT; 86 to * — FXRD
	6	7041	LOCKWASHER (4)	84 to * — FXRT; 86 to * — FXRD
	7	7220	LOCKWASHER (2)	84 to * — FXRT; 86 to * — FXRD
	8	7748W	NUT (4)	84 to * — FXRT; 86 to * — FXRD
	9	10054	CLIP	84 — FXRT
	10	45382—83	SPRING, slider (2)	84 to * — FXRT; 86 to * — FXRD
	11	45385—83	SPRING (2)	84 to * — FXRT; 86 to * — FXRD
	12	45386—83	SPACER, seal (2)	84 to * — FXRT; 86 to * — FXRD
	13	45387—83	OIL SEAL, slider (2)	84 to * — FXRT; 86 to * — FXRD
	14	45388—83	RETAINING RING, oil seal (2)	84 to * — FXRT; 86 to * — FXRD
	15	45389—83	CAP, slider tube (2)	84 to Early 86 — FXRT; Early 86 — FXRD
		45389—86	CAP, slider tube (2)	Late 86 to * — FXRT, FXRD
	16	45392—83	SLIDER TUBE (2)	84 to Early 86 — FXRT; Early 86 — FXRD
		45392—86	SLIDER TUBE (2)	Late 86 to * — FXRT, FXRD
	17	45403—84	LOWER STOP (2)	84 to * — FXRT; 86 to * — FXRD
	18	45404—75	DUST COVER (2)	84 to * — FXRT; 86 to * — FXRD
	19	45405—75A	SCREW WITH WASHER, damper tube (2)	84 to * — FXRT; 86 to * — FXRD
	20	45410—84	AXLE CAP, left slider	84 to * — FXRT; 86 to * — FXRD
	21	45412—75	RING, damper tube (4)	84 to * — FXRT; 86 to * — FXRD
	22	45413—84	BUSHING, upper — fork slider (2)	84 to * — FXRT; 86 to * — FXRD
	23	45416—84	BUSHING, lower — fork slider (2)	N/A 84 to * — FXRT; 86 to * — FXRD
		45589—84	BRACKET, lower (HDI part only)	86 to * — FXRT, FXRD
	23A	45718—71	NUT, fork stem	84 to * — FXRT; 86 to * — FXRD
	24	45736—78B	BRACKET, upper	84 to * — FXRT; 86 to * — FXRD
	25	45782—72A	SCREW INSERT (2)	84 to * — FXRT; 86 to * — FXRD
	26	45790—80	DRAIN SCREW, slider (2)	84 to * — FXRT; 86 to * — FXRD
	27	45791—84A	FORK SLIDER & TUBE ASSEMBLY, left	84 to * — FXRT; 86 to * — FXRD
	28	45793—84	FORK SLIDER & TUBE ASSEMBLY, right	84 — FXRT
		45793—85A	FORK SLIDER & TUBE ASSEMBLY, right	85 to * — FXRT; 86 to * — FXRD
	29	45906—84	SLIDER, right	84 — FXRT
		45909—83	SLIDER, right	85 to * — FXRT; 86 to * — FXRD
		45912—84	SLIDER, left	84 to * — FXRT; 86 to * — FXRD
	29A	45913—84	DAMPER TUBE (2) — includes item 21	84 to * — FXRT; 86 to * — FXRD
	30	45982—73	O-RING, slider tube cap (2)	84 to * — FXRT; 86 to * — FXRD
	31	45994—84	AXLE CAP, right slider	84 to * — FXRT; 86 to * — FXRD
	32	45997—73	WASHER, slider tube cap (2)	84 to * — FXRT; 86 to * — FXRD
	33	45998—73	STUD (4)	84 to * — FXRT; 86 to * — FXRD
	34	46020—84	BUSHING, brake caliper	84 to * — FXRT; 86 to * — FXRD
	36	47692—84	BRACKET, lower — w/bearing and shield	84 to * — FXRT; 86 to * — FXRD
	37	47830—86	FORK STOP (2)	N/A 86 to * — FXRT, FXRD
		48140—84	TUMBLER, fork lock	86 to * — FXRT, FXRD
	38	48300—60	ROLLER BEARING, w/cup (2)	84 to * — FXRT; 86 to * — FXRD
	39	48315—60	BEARING CUP (2)	84 to * — FXRT; 86 to * — FXRD
	40	48361—80	DUST SHIELD, head bearing — upper	84 to * — FXRT; 86 to * — FXRD
	41	48365—48A	DUST SHIELD, head bearing — lower	84 to * — FXRT; 86 to * — FXRD
	42	59254—72	REFLECTOR (amber) (2)	84 to * — FXRT; 86 to * — FXRD
	43	70191—73A	CABLE	84 to * — FXRT; 86 to * — FXRD

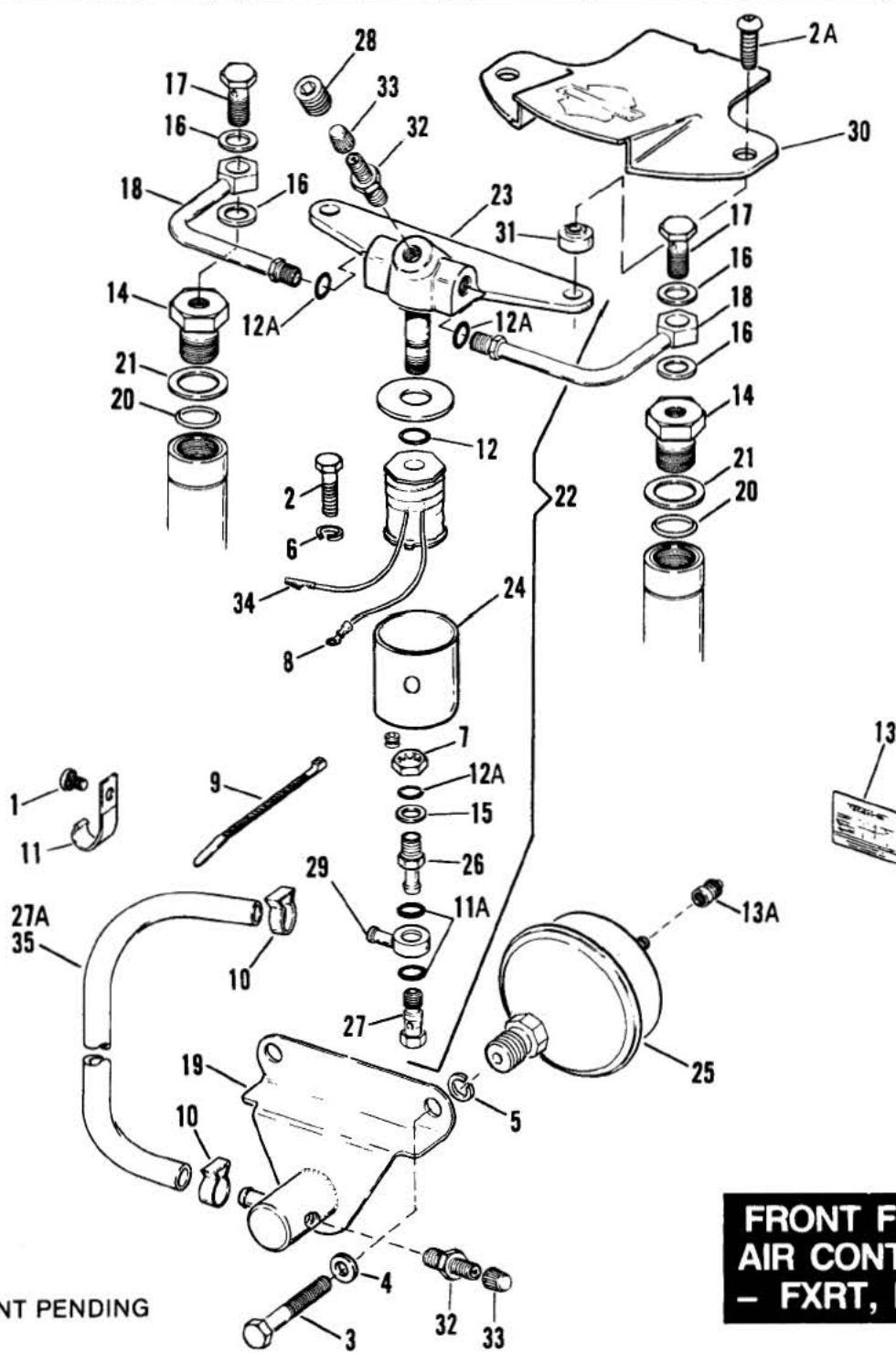

NOTE: PATENT PENDING

**FRONT FORK  
AIR CONTROL  
- FXRT, FXRD**

RETAIL PRICE	INDEX NO.	PART NO.	NAME	USED ON
	1	2823	SCREW	84 — FXRT
	2	3987	BOLT (2)	84 to * — FXRT; 86 to * — FXRD
	2A	4011	SCREW (2)	86 to * — FXRT
	3	4411	BOLT (2)	84 & 86 — FXRT
		4724	BOLT (2)	86 to * — FXRT, FXRD
	4	6701	WASHER (2)	84 to * — FXRT; 86 to * — FXRD
	5	7038	LOCKWASHER (2)	84 to * — FXRT; 86 to * — FXRD
	6	7041	LOCKWASHER (2)	84 to * — FXRT; 86 to * — FXRD
	7	7544	NUT	84 & Early 85 — FXRT
	8	9857	WIRE TERMINAL, ring type, No. 10 hole — #16-22 wire	84 to * — FXRT; 86 to * — FXRD
	9	10006	CABLE STRAP	84 to * — FXRT; 86 to * — FXRD
	10	10080	CLAMP (2)	84 to * — FXRT
	11	10054	CLIP	84 — FXRT
	11A	11132	O-RING (2)	86 to * — FXRT, FXRD
	12	11170	O-RING	84 to * — FXRT; 86 to * — FXRD
	12A	11171	O-RING (3)	84 to * — FXRT; 86 to * — FXRD
	13	14052—85	LABEL, air suspension	85 to * — FXRT; 86 to * — FXRD
	13A	41123—79	VALVE CAP	84 to * — FXRT; 86 to * — FXRD
	14	45389—83	CAP, fork slider tube (2)	84 to * — FXRT; 86 to * — FXRD
	15	45406—75	WASHER (2)	84 & Early 85 — FXRT
	16	45583—83	GASKET (4)	84 to * — FXRT; 86 to * — FXRD
	17	45585—83	FITTING (2)	84 to * — FXRT; 86 to * — FXRD
	18	45587—83A	TUBE (2)	84 to * — FXRT; 86 to * — FXRD
	19	45621—83	BRACKET	N/A 84 & 85 — FXRT
		45621—83A	BRACKET	86 to * — FXRT, FXRD
	20	45982—73	O-RING, fork slider tube cap (2)	84 to * — FXRT; 86 to * — FXRD
	21	45997—73	WASHER, fork slider tube cap (2)	84 to * — FXRT; 86 to * — FXRD
	22	46450—83A	VALVE ASSEMBLY, complete	84 & Early 85 — FXRT
		46450—85	VALVE ASSEMBLY, complete	N/A Late 85 — FXRT
		46450—86	VALVE ASSEMBLY, complete	86 to * — FXRT, FXRD
	23	46451—83	VALVE BODY	84 & Early 85 — FXRT
		46451—85	VALVE BODY	Late 85 to * — FXRT; 86 to * — FXRD
	24	46452—83	SOLENOID	84 & Early 85 — FXRT
		46452—85	VALVE ACTUATOR	Late 85 to * — FXRT; 86 to * — FXRD
	25	46454—83	ACCUMULATOR	84 to * — FXRT; 86 to * — FXRD
	26	46455—84	FITTING	84 & Early 85 — FXRT
		46455—85	FITTING	Late 85 — FXRT
	27	46456—84	BOLT, fitting	N/A 84 & Early 85 — FXRT
		46461—86	BOLT, fitting	86 to * — FXRT, FXRD
	27A	46457—85	HOSE, fitting to valve	N/A Late 85 — FXRT
		46457—86	HOSE, fitting to valve	N/A 86 to * — FXRT, FXRD
	28	46458—86	PLUG	86 to * — FXRT, FXRD
	29	46459—86	FITTING	86 to * — FXRT, FXRD
	30	46501—86	COVER, solenoid	86 to * — FXRT, FXRD
	31	46503—86	SPACER, (2)	86 to * — FXRT
	32	54316—83A	VALVE STEM ASSEMBLY	84 to * — FXRT; 86 to * — FXRD
	33	54323—85	VALVE CAP	84 to * — FXRT; 86 to * — FXRD
	34	72038—71	WIRE TERMINAL, socket type	84 to * — FXRT; 86 to * — FXRD

NOTE: Hose is sold only in bulk length under the following part number. Cut to required length.  
 35 63500—68 HOSE, 3/8 I.D. x 5/8 O.D. reinforced rubber (25 ft. lg.) 84 & Early 85 — FXRT

NOTE: PATENT PENDING

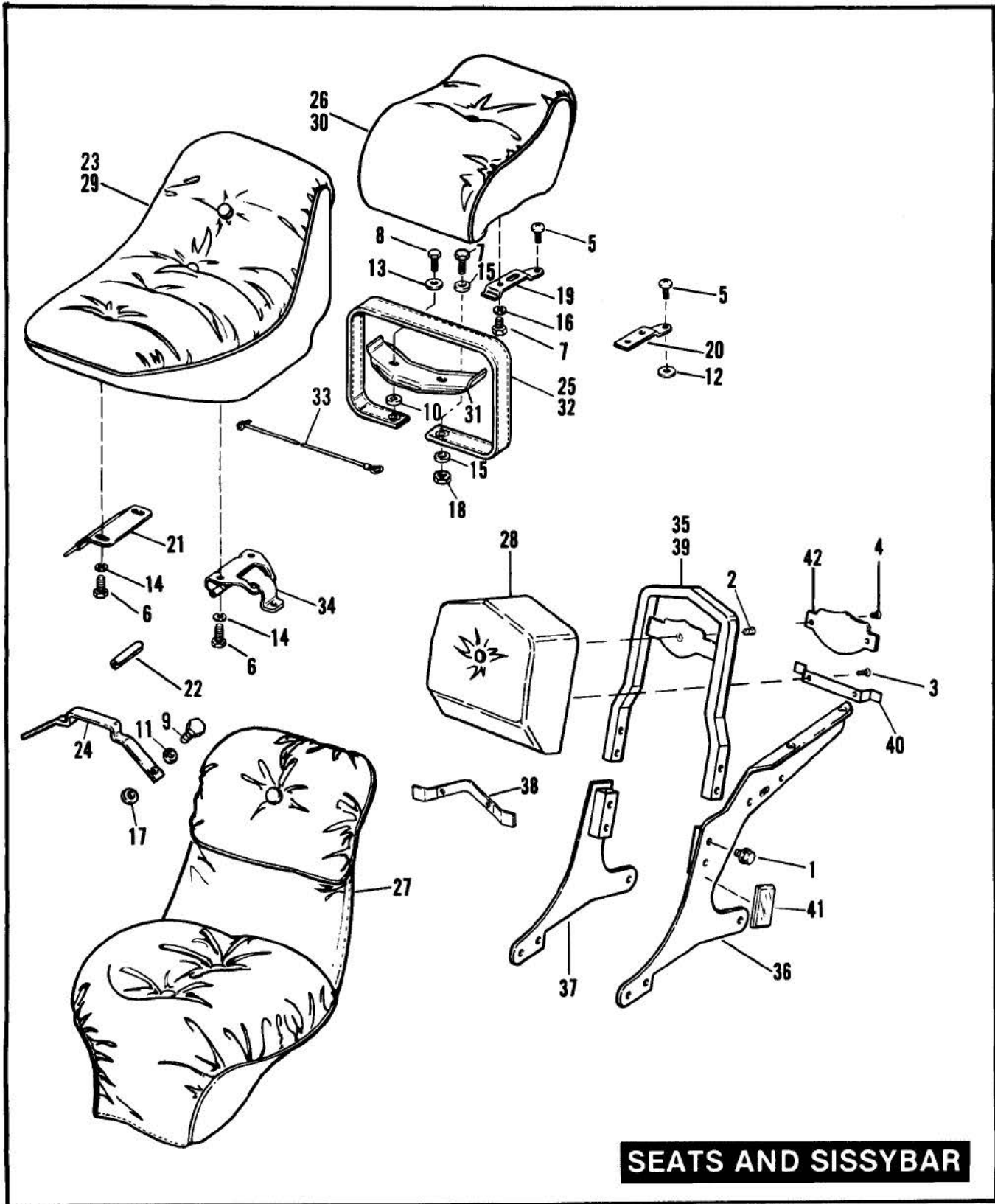

**SEATS AND SISSYBAR**



## SEATS AND SISSYBAR

RS26

RETAIL PRICE	INDEX NO.	PART NO.	NAME	USED ON
	1	919	BOLT (4)	84 to * — FXRT; 86 to * — FXRD
	2	1615	SCREW	84 — FXRT
	3	2607	SCREW (2)	84 to * — FXRT
	4	2711	SCREW (2)	84 to * — FXRT
	5	2733	SCREW	86 to * — FXR
		2757W	SCREW	84 to * — FXRS, FXRT; 86 to * — FXRD
	6	3487	BOLT (4)	84 to * — FXRS, FXRT; 86 to * — FXRD
	7	3767B	SCREW (2; 3 — FXR)	84 to * — FXRS, FXRT; 86 to * — FXRD
	8	3960W	BOLT (2)	84 to * — FXRS
		3996	BOLT (2)	84 to * — FXRT
	9	3991	BOLT (2)	86 to * — FXR
	10	5724	SPACER (2)	84 to * — FXRS
	11	6109	WASHER (2)	86 to * — FXR
	12	6410	WASHER	84 to * — FXRT; 86 to * — FXRD
	13	6645	WASHER (2)	84 to * — FXRS, FXRT
	14	6702	WASHER (4)	84 — FXRS
	15	6703	WASHER (2)	86 to * — FXR
	16	7036	LOCKWASHER (2)	84 to * — FXRS; 86 — FXRT
	17	7232	LOCKNUT (2)	86 to * — FXR
	18	7686	LOCKNUT	86 to * — FXR
	19	51651—79	BRACKET, rear seat	84 to * — FXRS
	20	51652—83	BRACKET, rear seat	84 — FXRT; 86 to * — FXR
	21	52020—82	BRACKET ASSEMBLY	84 to * — FXRS, FXRT
	22	52041—82	PIN, seat hinge	84 to * — FXRS, FXRT
	23	52106—86	SEAT (black vinyl)	86 to * — FXR
	24	52107—86	BRACKET, seat	86 to * — FXR
	25	52108—86	PASSENGER STRAP	86 to * — FXR
	26	52111—83	SEAT, rear	84 — FXRT
	27	52111—85A	SEAT, rear	85 to * — FXRT
		52005—85A	SEAT, rear	86 to * — FXRD
	28	52123—83	BACK REST	N/A 84 — FXRT
	29	52138—82A	SEAT, front (black vinyl)	84 to * — FXR, FXRT
		52202—86	SEAT, front	86 to * — FXRD
	30	52139—82	SEAT, rear (black vinyl)	84 to * — FXRS
	31	52141—82	BRACKET, passenger strap	84 to * — FXRS
	32	52142—82A	PASSENGER STRAP	84 to * — FXRS
	33	52213—82	CORD, seat stop	84 to * — FXRS, FXRT; 86 to * — FXRD
	34	52355—82	LATCH, seat	84 to * — FXRS, FXRT; 86 to * — FXRD
	35	52739—83	SISSY BAR ASSEMBLY	84 — FXRT
	36	52757—82A	SIDE PLATE, left	84 to * — FXRT
		52790—86	SIDE PLATE, left	86 to * — FXRD
	37	52789—86	SIDE PLATE, right	86 to * — FXRD
		52798—87	SIDE PLATE, right	84 to * — FXRT
	38	52765—85	BRACKET, backrest	85 to * — FXRT; 86 to * — FXRD
	39	52766—85	SISSY BAR	85 to * — FXRT
	40	52771—82	BRACKET, backrest	84 — FXRT
	41	59267—83	REFLECTOR, red (2)	84 to * — FXRT; 86 to * — FXRD
	42	99013—83	MEDALLION	84 to * — FXRT

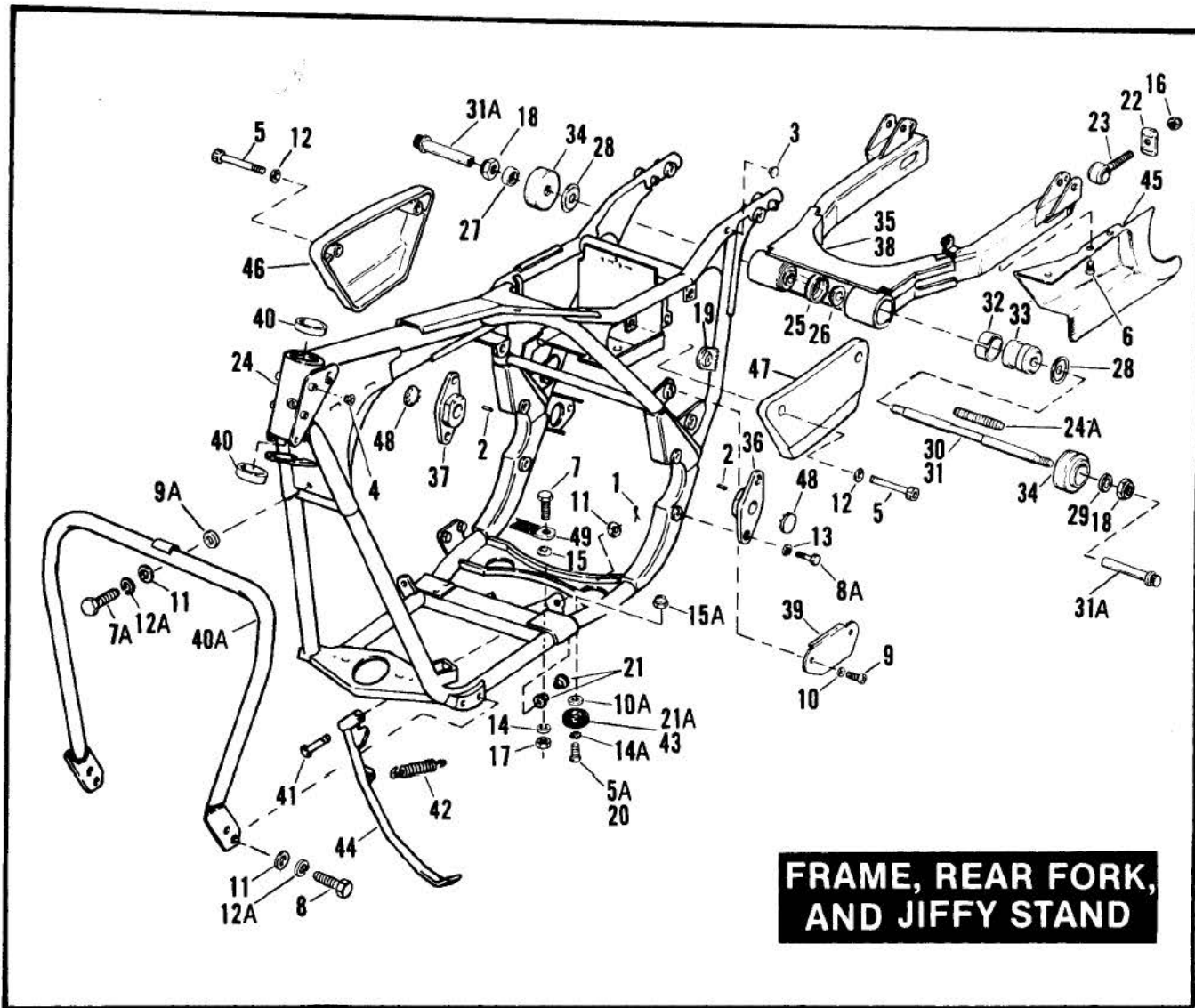

**FRAME, REAR FORK AND JIFFY STAND**

**RS27-1**

RETAIL PRICE	INDEX NO.	PART NO.	NAME	USED ON
	1	520W	COTTER PIN .....	84 to * - All Models
	2	604	ROLL PIN (2) .....	84 to * - All Models
	3	728	PLUG (2) .....	84 to * - All Models
	4	735	PLUG, fairing mounting holes (4) .....	Late 84 to * - FXRS; 86 to * - FXR
	5	813	SCREW (4) .....	84 to * - All Models
	5A	2538	SCREW .....	84 to * - All Models
	6	2757W	SCREW (3) .....	85 to * - FXRS, FXRT; 86 to * - FXRD
	7	3987	BOLT .....	85 to * - All Models
	7A	4371W	SCREW .....	86 to * - FXRD
	8	4716W	BOLT (4) .....	86 to * - FXRD
	8A	4729	BOLT (4) .....	84 to * - All Models
	9	4811	SCREW (2) .....	85 to * - All Models
	9A	6019	WASHER .....	86 to * - FXRD
	10	6099	WASHER (2) .....	85 to * - All Models
	10A	6257W	WASHER .....	85 to * - All Models
	11	6701	WASHER (6 - FXRD) .....	84 to * - All Models

RETAIL PRICE	INDEX NO.	PART NO.	NAME	USED ON
	12	6703	WASHER (4)	84 to * — All Models
	12A	7038	WASHER	86 to * — FXRD
	13	7039	LOCKWASHER (4)	84 to * — All Models
	14	7041	LOCKWASHER	85 to * — All Models
	14A	7124	LOCKWASHER	85 — FXRS, FXRT
	15	7127	LOCKWASHER	85 — FXRS, FXRT
		7232	LOCKWASHER	86 to * — FXR, FXRS
	15A	7686	LOCKNUT	85 to * — All Models
	16	7725	LOCKNUT (2)	84 to * — All Models
	17	7748W	NUT	85 to * — All Models
	18	7825	LOCKNUT (2)	Early 84 — FXRS, FXRT
		7828	LOCKNUT (2)	Late 84 & 85 — All Models
	19	8099	WELL NUT (4)	84 to * — FXRS, FXRT
	20	8501	RIVET (2)	84 — FXRS, FXRT
	21	11404	BUSHING (2)	84 — FXRS, FXRT
	21A	11469	BUMPER, jiffy stand	85 to * — All Models
	22	41112-79	END COVER, rear fork (2)	84 to * — All Models
	23	41570-77	ADJUSTER, rear axle (2)	84 to * — All Models
	24	47005-82D	FRAME	85 to * — All Models
		48036-84B	FRAME (HDI part only)	N/A 86 to * — FXR, FXRS, FXRT
	24A	47505-86	STUD, pivot	86 to * — All Models
	25	47510-80	RING, plastic retainer (2)	84 to * — All Models
	26	47511-80	SPACER (2)	84 to * — All Models
	27	47512-82	SPACER, pivot shaft — right	84 & 85 — All Models
	28	47513-80	NYLON WASHER (2)	84 to * — All Models
	29	47514-80	SPACER, pivot shaft — left	84 & 85 — All Models
	30	47515-80A	PIVOT SHAFT KIT, includes items 18, 27, 29 & 31	84 to * — All Models
	31	47515-82A	PIVOT SHAFT, rear fork	84 & 85 — All Models
	31A	47515-86	BOLT, pivot (2)	86 to * — All Models
	32	47538-79	TOLERANCE RING, bushing (2)	84 to * — All Models
	33	47556-81	BUSHING ASSEMBLY, with 47538-79 (2)	84 to * — All Models
	34	47564-82	RUBBER MOUNT, rear fork (2)	84 & 85 — All Models
		47564-86	MOUNT, rear fork (2)	86 to * — All Models
	35	47820-81A	REAR FORK	84 to * — All Models
	36	47825-81	END CAP, left	84 to * — All Models
	37	47826-81	END CAP, right	84 to * — All Models
	38	47829-83	REAR FORK (without chain guard bracket)	84 — FXRT
	39	48039-85	TRIM PANEL, left side	85 to * — All Models
	40	48315-60	BEARING, cup (2)	84 to * — All Models
	40A	49017-82A	HIGHWAY BAR KIT	86 to * — FXRD
	41	50009-82	PIN	84 to * — All Models
	42	50011-30A	SPRING	84 to * — All Models
	43	50016-82	BUMPER, jiffy stand	84 — FXRS, FXRT
	44	50031-84A	JIFFY STAND	84 to * — FXRS; 86 to * — FXR
		50069-82A	JIFFY STAND	Early 84 — FXRT
		50069-84	JIFFY STAND	Late 84 & 85 — FXRT
		50069-86	JIFFY STAND	86 to * — FXRT, FXRD
	45	60397-85A	DEBRIS DEFLECTOR	85 to * — FXRS, FXRT; 86 to * — FXRD
	46	66342-84	SIDE COVER, right (gold)	N/A 84 — FXRT
		66349-84	SIDE COVER, right	84 to * — FXRS, FXRT; 86 to * — FXR
	47	66343-84	SIDE COVER, left (gold)	N/A 84 — FXRT
		66350-84	SIDE COVER, left	84 to * — FXRS, FXRT; 86 to * — FXR
	48	67830-59	PLUG (2)	84 to * — All Models
	49	70186-82	GROUND STRAP	85 to * — All Models

# FOOTRESTS – FXR, FXRS, FXRT

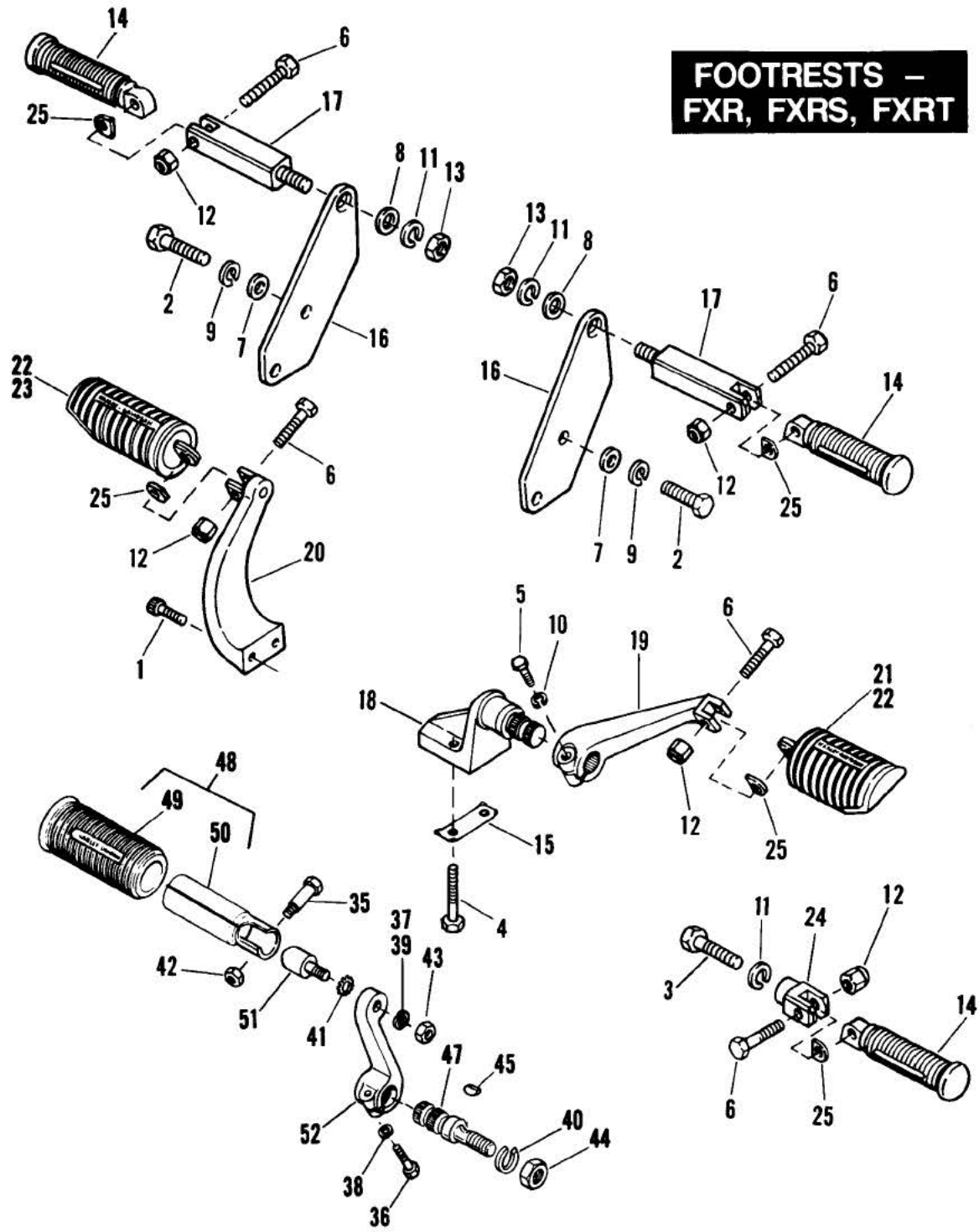

**FOOTRESTS — FXR, FXRS AND FXRT**

RETAIL PRICE	INDEX NO.	PART NO.	NAME	USED ON
	1	920	SCREW (2)	84 to * — FXRS, FXRT; 86 to * — FXR
	2	2851	BOLT (4)	84 to * — FXRS
	3	3486	BOLT (2)	84 to * — FXRS; 86 to * — FXR
	4	3503	BOLT (2)	84 to * — FXRS, FXRT; 86 to * — FXR
	5	4014W	BOLT	84 to * — FXRS, FXRT; 86 to * — FXR
	6	4721	BOLT (4; 6 — FXRS)	84 to * — FXRS, FXRT; 86 to * — FXR
	7	6701	WASHER (4)	84 to * — FXRS
	8	6718	WASHER (2)	84 to * — FXRS
	9	7038	LOCKWASHER (4)	84 to * — FXRS
	10	7041	LOCKWASHER	84 to * — FXRS, FXRT; 86 to * — FXR
	11	7068	LOCKWASHER (4; 2 — FXR)	84 to * — FXRS; 86 to * — FXR
	12	7778	LOCKNUT (4; 6 — FXRS)	84 to * — FXRS, FXRT; 86 to * — FXR
	13	7880	NUT (2)	84 to * — FXRS
	14	33048—72	FOOTREST (2 — FXR; 4 — FXRS)	84 to * — FXRS; 86 to * — FXR
		33189—63	COVER, only (black) (2 — FXR; 4 — FXRS)	84 to * — FXRS; 86 to * — FXR
	15	42334—82	LOCKPLATE, front	84 to * — FXRS, FXRT; 86 to * — FXR
	16	49126—77B	MOUNTING PLATE (2)	84 to * — FXRS
	17	49127—77	FOOTREST SUPPORT (2)	84 to * — FXRS
	18	50531—81	BRACKET, footrest — front	84 to * — FXRS, FXRT; 86 to * — FXR
	19	50636—81A	BRACKET, right footrest — front	84 to * — FXRS, FXRT; 86 to * — FXR
	20	50639—81	BRACKET, left footrest — front	84 to * — FXRS, FXRT; 86 to ;3 — FXR
	21	50643—82	FOOTREST W/COVER, right	84 to * — FXRS, FXRT; 86 to * — FXR
	22	50646—82	COVER, only (black)(2)	84 to * — FXRS, FXRT; 86 to * — FXR
	23	50647—82	FOOTREST W/COVER, left	84 to * — FXRS, FXRT; 86 to * — FXR
	24	50900—72	SUPPORT, footrest (2)	84 to * — FXRS; 86 to * — FXR
	25	50912—72	SPRING WASHER (as req'd)	84 to * — FXRS, FXRT; 86 to * — FXR

**FOOTRESTS — FXRT REAR**

35	2608	SHOULDER BOLT (2)	84 & 85 — FXRT
	4724	BOLT (2)	86 to * — FXRT
36	3825	BOLT (23)	Late 84 to * — FXRT
	3839W	BOLT (2)	Early 84 — FXRT
37	6379W	WASHER (2)	85 to * — FXRT
38	7036	LOCKWASHER (2)	84 to * — FXRT
39	7038	LOCKWASHER (2)	84 — FXRT
40	7068	LOCKWASHER (2)	84 to * — FXRT
41	7145W	LOCKWASHER	85 to * — FXRT
42	7628	LOCKNUT (2)	86 to * — FXRT
	7739	LOCKNUT (2)	84 to * — FXRT
43	7776W	LOCKNUT (2)	85 to * — FXRT
	7800W	NUT (2)	84 — FXRT
44	7845	NUT (2)	84 to * — FXRT
45	23985—18	KEY, footrest stud (2)	85 to * — FXRT
47	50921—83	STUD (2)	84 to * — FXRT
48	50939—52	FOOTREST, with cover (2)	84 to * — FXRT
49	50940—52	COVER, only (black)(2)	84 to * — FXRT
50	50946—52	FOOTREST, only (2)	N/A
51	50973—65	STUD (2)	84 to * — FXRT
52	52700—81	SUPPORT (2)	84 to * — FXRT

# FOOTBOARDS — FXRD

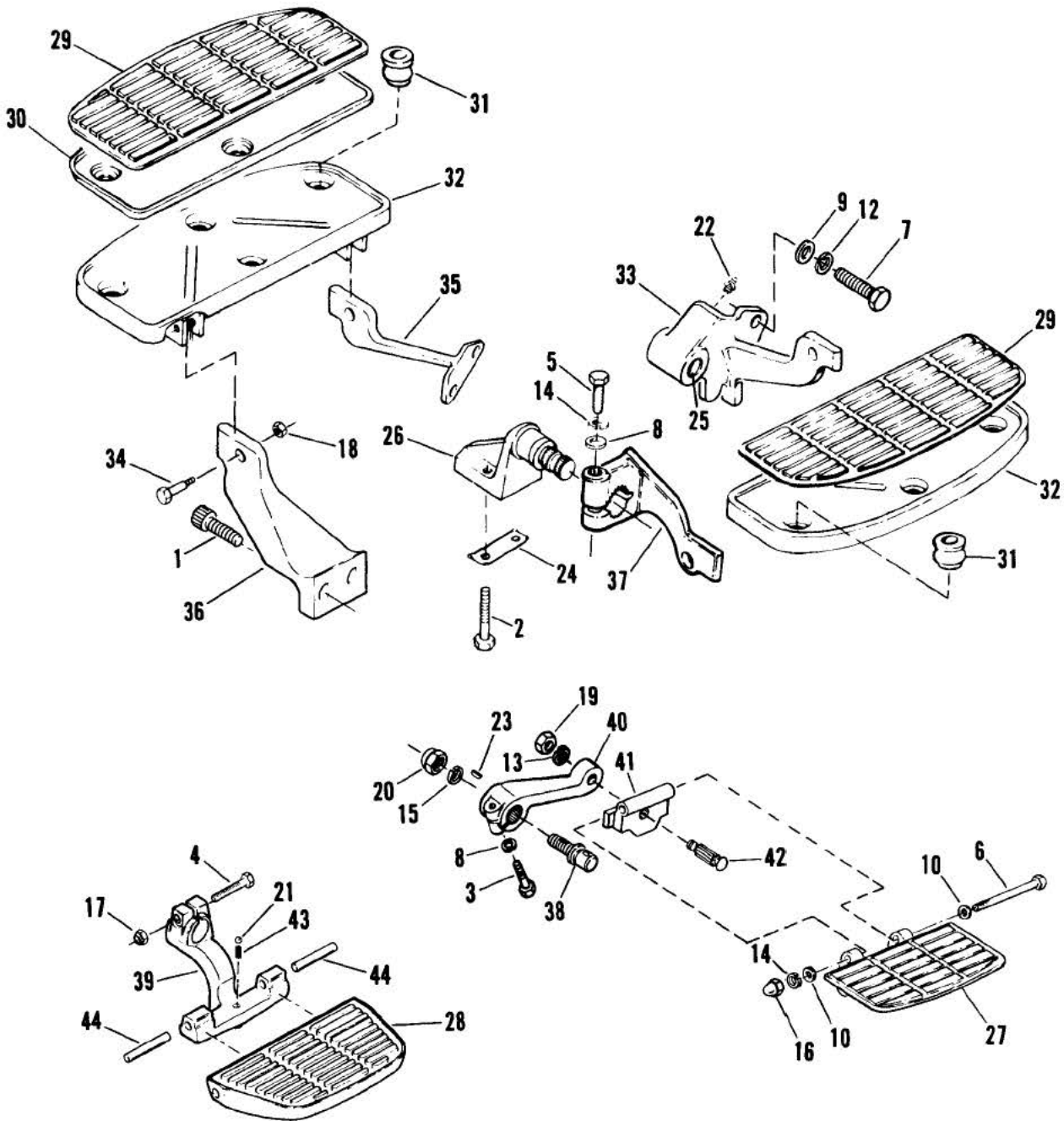

RETAIL PRICE	INDEX NO.	PART NO.	NAME	USED ON
	1	920	SCREW (2)	86 to * — FXRD
	2	3503	BOLT (2)	86 to * — FXRD
	3	3825	BOLT (2)	Early 86 — FXRD
	4	3826	BOLT (2)	Late 86 to * — FXRD
	5	4014W	SCREW	86 to * — FXRD
	6	4100HW	BOLT (2)	Early 86 — FXRD
	7	4716W	BOLT (4)	86 to * — FXRD
	8	6317	WASHER (2)	86 to * — FXRD
	9	6701	WASHER (4)	86 to * — FXRD
	10	6702	WASHER (4)	Early 86 — FXRD
	12	7038	LOCKWASHER (4)	86 to * — FXRD
	13	7039	LOCKWASHER (2)	Early 86 — FXRD
	14	7041	LOCKWASHER (3 — Early 86)	86 to * — FXRD
	15	7068	LOCKWASHER (2)	86 to * — FXRD
	16	7507	ACORN NUT (2)	Early 86 — FXRD
	17	7682	LOCKNUT (2)	Late 86 to * — FXRD
	18	7742	LOCKNUT (4)	86 to * — FXRD
	19	7837W	LOCKNUT (2)	Early 86 to * — FXRD
	20	7845	LOCKNUT (2)	86 to * — FXRD
	21	8858	BALL (2)	Late 86 to * — FXRD
	22	9851	GREASE FITTING, front bracket	86 to * — FXRD
	23	23985—18	KEY (2)	86 to * — FXRD
	24	42334—82	LOCKPLATE, right rear bracket	86 to * — FXRD
	25	47247—83	BUSHING, front bracket (2)	86 to * — FXRD
	26	50531—81	BRACKET, right footboard	86 to * — FXRD
	27	50604—83	FOOTBOARD ASSEMBLY, passenger (2)	N/A Early 86 — FXRD
		50606—83	PAD, footboard, passenger (2)	Early 86 — FXRD
	28	50606—86	PAD, footboard, passenger (2)	Late 86 to * — FXRD
		50613—86	PLATE, footboard, passenger (2)	Late 86 to * — FXRD
	29	50614—66	PAD, footboard (2)	86 to * — FXRD
	30	50619—74A	PLATE, footboard (without pad) (2)	86 to * — FXRD
	31	50620—74	RUBBER MOUNT, footboard (8)	86 to * — FXRD
	32	50632—85	FOOTBOARD, includes items 13 - 15 (2)	86 to * — FXRD
	33	50634—85	MOUNTING BRACKET, right — front	86 to * — FXRD
	34	50635—82	BOLT, footboard hinge (4)	86 to * — FXRD
	35	50660—85	MOUNTING BRACKET, left — front	86 to * — FXRD
	36	50662—85	MOUNTING BRACKET, left — rear	86 to * — FXRD
	37	50664—85	MOUNTING BRACKET, right — rear	86 to * — FXRD
	38	50960—86	STUD, right	Late 86 to * — FXRD
		50961—86	STUD (2)	Early 86 — FXRD
		50962—86	STUD, left	Late 86 to * — FXRD
	39	52713—86	FOOTBOARD SUPPORT, passenger (black wrinkle)(2)	Late 86 to * — FXRD
	40	52714—86	FOOTBOARD SUPPORT, passenger (black wrinkle)(2)	Early 86 — FXRD
	41	52715—86	FOOTBOARD BRACKET (2)	Early 86 — FXRD
	42	52717—86	SCREW (2)	Early 86 — FXRD
	43	50932—86	SPRING (2)	Late 86 to * — FXRD
	44	50933—86	PIN, pivot (4)	Late 86 to * — FXRD

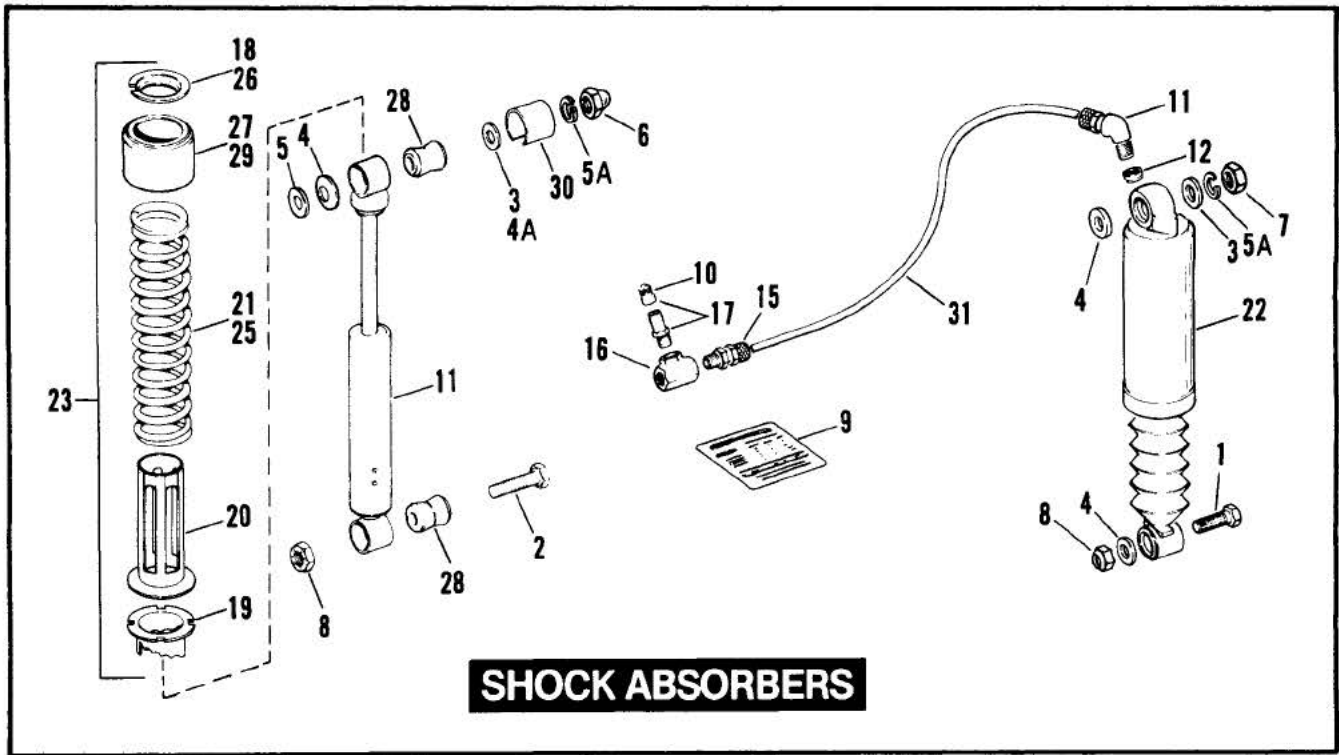



# SHOCK ABSORBERS

RS29

RETAIL PRICE	INDEX NO.	PART NO.	NAME	USED ON
	1	1614	BOLT (2)	84 to * — FXRT; 85 to * — FXRS; 86 to * — FXR
	2	4081	BOLT (2)	84 — FXRS
	3	6416	WASHER (2)	84 to * — FXRT; 86 to * — FXR, FXRD
	4	6530	WASHER (2; 4 — FXRT & FXRD)	84 to * — All Models
	4A	6701	WASHER (2)	84 to * — FXRS
	5	6962	WASHER (2)	85 to * — FXRS, FXRT; 86 to * — FXR
	5A	7038	LOCKWASHER (2)	84 to * — FXRT; 86 to * — FXR, FXRD
	6	7680W	ACORN NUT (2)	84 to * — FXRS; 86 to * — FXR
	7	7783	NUT (2)	84 to * — FXRT; 86 to * — FXRD
	8	7812W	NUT (2)	84 to * — FXRS, FXRT; 86 to * — FXR
	9	14052—83	DECAL, air suspension pressures	84 — FXRT
		14052—85	DECAL, air suspension pressures	85 to * — FXRT; 86 to * — FXRD
	10	41123—79	VALVE CAP	84 — FXRT
	11	54310—83	ELBOW FITTING (2)	84 — FXRT
	12	54311—83	SEAL NUT (2)	84 — FXRT
	15	54314—83	CONNECTOR, male (2)	84 — FXRT
	16	54315—83	TEE FITTING	84 — FXRT
	17	54316—83A	AIR VALVE AND CAP	84 — FXRT
	18	54473—79	SPRING SEAT (2)	84 to * — FXRS; 86 to * — FXR
	19	54474—79	ADJUSTER, spring (2)	84 to * — FXRS; 86 to * — FXR
	20	54475—79	GUIDE, spring (2 — FXR & FXRS)	84 to * — FXRS; 85 to * — FXRT; 86 to * — FXR, FXRD
	21	54477—84	SPRING (2)	84 to * — FXRS; 86 to * — FXR
	22	54491—83	SHOCK ABSORBER, complete (2 — 84)	84 — FXRT
		54491—85	SHOCK ABSORBER, right — complete	85 to * — FXRT; 86 to * — FXRD
	23	54492—85	SHOCK ABSORBER, left — complete (black)	85 to * — FXRT; 86 to * — FXRD
		54502—84	SHOCK ABSORBER, complete (2)	84 to * — FXRS; 86 to * — FXR
	24	54493—85	SHOCK ABSORBER, only (black)	85 to * — FXRT; 86 to * — FXRD
		54518—84	SHOCK ABSORBER, only (2)	84 to * — FXRS; 86 to * — FXR
	25	54494—85	SPRING, shock absorber (black)	85 to * — FXRT; 86 to * — FXRD
	26	54495—85	SPRING SEAT, upper (black)	85 to * — FXRT; 86 to * — FXRD
	27	54496—85	COVER, shock absorber — upper (black)	85 to * — FXRT; 86 to * — FXRD
	28	54523—82	BUSHING (4 — FXR & FXRS; 2 — FXRT & FXRD)	84 to * — FXRS; 85 to * — FXRT
	29	54701—82	COVER, shock absorber (2)	84 to * — FXRS; 86 to * — FXR
	30	54705—81	COVER, stud (2)	84 to * — FXRS

NOTE: Tube is sold in bulk length under the following part number. Cut to required length.

31	54324—85	TUBE, 1/4 O.D. x 25 ft. lg.	84 — FXRT
----	----------	-----------------------------	-----------

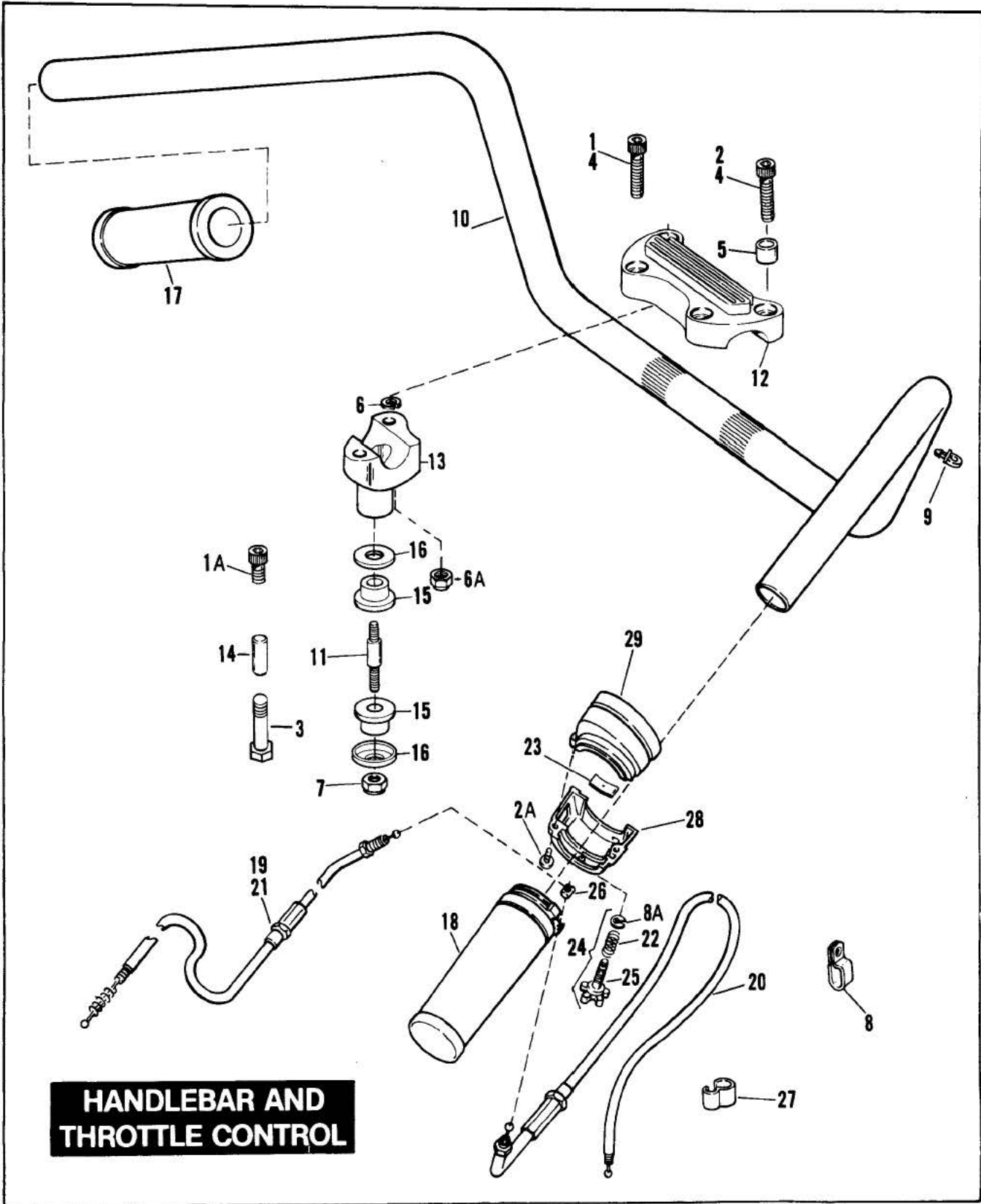

# HANDLEBAR AND THROTTLE CONTROL

RS30

RETAIL PRICE	INDEX NO.	PART NO.	NAME	USED ON
	1	853	SCREW (2)	84 & 85 — FXRS, FXRT
	1A	867	SCREW (2)	86 to * — FXRT, FXRD
	2	871	SCREW (2)	86 to * — FXRD
	2A	2508	SCREW (2)	84 & 85 — FXRS, FXRT
	3	3498	BOLT (2)	Early 84 — FXRS, FXRT
	4	4809	SCREW (4 — FXRT; 2 — FXRD)	86 to * — FXRT, FXRD
		4816	SCREW (2; 4 — FXR)	84 to * — FXRS; 84 & 85 — FXRT; 86 to * — FXR
	5	5736	SPACER (2)	84 & 85 — FXRS, FXRT
		5743	SPACER (2)	86 to * — FXRD
	6	7042	LOCKWASHER (2)	84 & 85 — FXRS, FXRT; 86 to * — FXR, FXRS
	6A	7739	LOCKNUT (4)	85 to * — All Models
		7740	LOCKNUT (4)	84 — FXRS, FXRT
	7	7744	LOCKNUT (2)	86 to * — FXRT, FXRD
		7768W	LOCKNUT (2)	Late 84 & 85 — FXRS, FXRT; 86 to * — FXR, FXRS
		7844	LOCKNUT (2)	86 to * — FXRT, FXRD
	8	9988	CLIP, throttle cables	84 to * — All Models
	8A	11155	RETAINING RING, adjusting screw	84 to * — All Models
	9	56073—83	RETAINER, wiring harness (4)	84 to * — All Models
	10	56081—82	HANDLEBAR	84 to * — FXRS; 86 to * — FXR
		56087—83	HANDLEBAR	84 to * — FXRT
		56087—86	HANDLEBAR (black)	86 to * — FXRD
	11	56105—84	STUD, handlebar (2)	Late 84 & 85 — FXRS, FXRT; 86 to * — FXR, FXRS
	12	56115—79A	CAP, clamp	84 to * — All Models
	13	56116—82	CLAMP, handlebar — right (left — FXR)	84 & 85 — FXRS, FXRT; 86 to * — FXR, FXRS
		56117—82	CLAMP, handlebar — left (right — FXR)	84 & 85 — FXRS, FXRT; 86 to * — FXR, FXRS
		56144—86	CLAMP, handlebar — right	86 to * — FXRT, FXRD
		56146—86	CLAMP, handlebar — left	86 to * — FXRT, FXRD
	14	56153—73	SPACER, handlebar mounting (2)	84 — FXRS, FXRT; 86 to * — FXRT, FXRD
	15	56158—73	RUBBER BUSHING, handlebar mounting (4)	84 to * — All Models
	16	56159—73	CUP WASHER, handlebar mounting (4)	84 to * — All Models
	17	56206—81A	GRIP, left	84 to * — All Models
	18	56220—81B	GRIP AND SLEEVE — right	84 to * — All Models
	19	56323—81C	CONTROL, idle	84 to * — FXRS; 86 to * — FXR
	20	56324—81C	CONTROL, throttle	84 to * — FXRS; 86 to * — FXR
		56336—83	CONTROL, throttle	84 to * — FXRT; 86 to * — FXRD
	21	56337—83	CONTROL, idle	84 to * — FXRT; 86 to * — FXRD
	22	56394—74	SPRING, adjusting screw	84 to * — All Models
	23	56396—74A	FRICTION SPRING, throttle grip	84 to * — All Models
	24	56397—74C	ADJUSTING SCREW KIT, includes items 8A, 22 & 25	84 to * — All Models
	25	56402—83A	ADJUSTING SCREW	84 to * — All Models
	26	56508—76	FERRULE, control wire (2)	84 to * — All Models
	27	70504—81	CLIP, throttle cables	84 to * — FXRS, FXRT
	28	71563—82	HOUSING, switch — lower	84 & 85 — FXRS, FXRT
		71563—82A	HOUSING, switch — lower	86 to * — FXR, FXRS, FXRT
		71595—86	HOUSING, switch — lower	86 to * — FXRD
	29	71564—82A	HOUSING, switch — upper	84 to * — All Models

NOTE: PATENT PENDING

# WINDSHIELD AND FAIRING - FXRT, FXRD

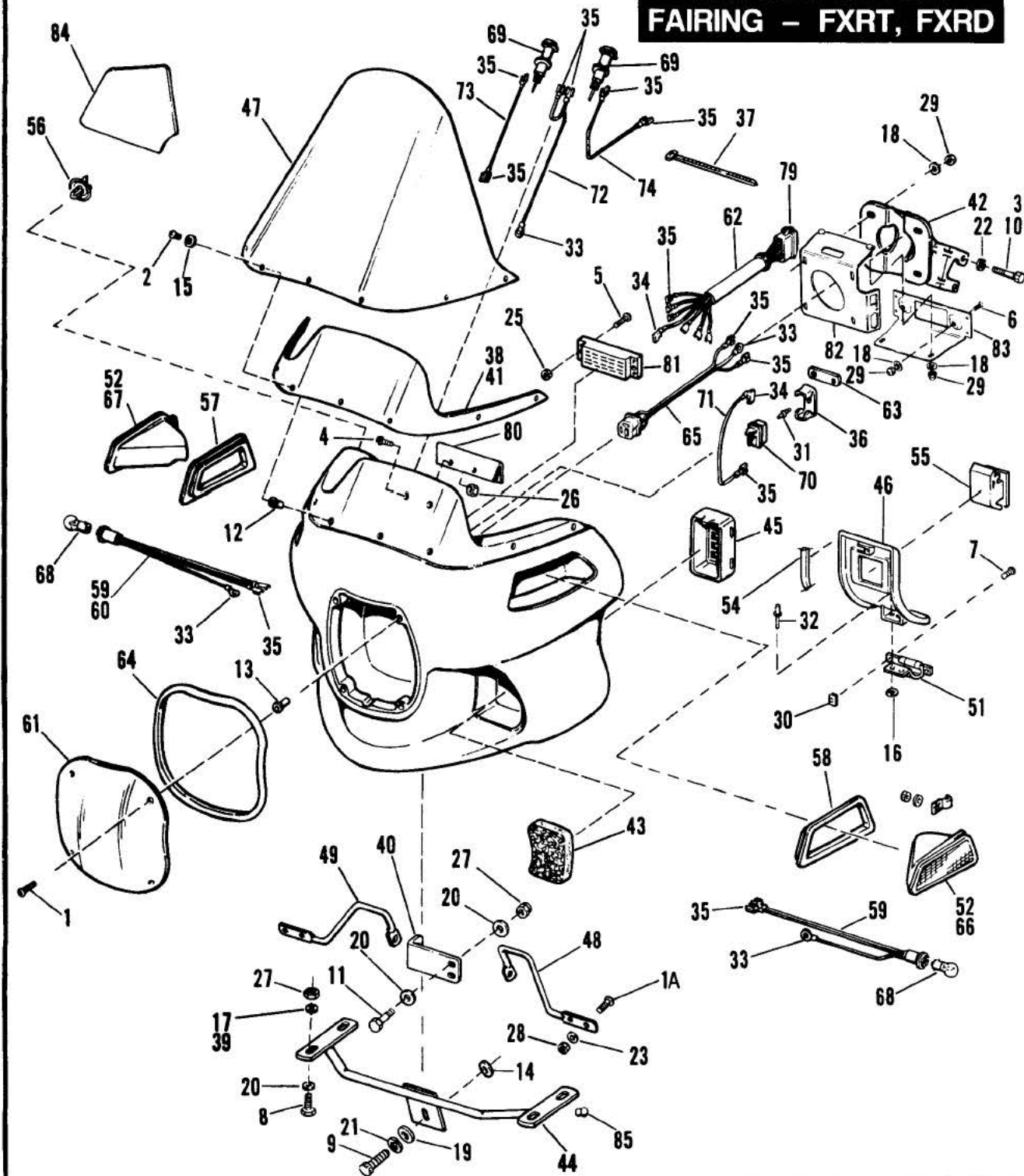

RETAIL PRICE	INDEX NO.	PART NO.	NAME	USED ON
			NOTE: For painted parts, see Dealer Accessory Guide.	
	1	922	SCREW (4)	84 to * — FXRT; 86 to * — FXRD
	1A	923	SCREW (4)	84 & 85 — FXRT
	2	933	SCREW (7)	84 to * — FXRT; 86 to * — FXRD
	3	1607	SCREW W/WASHER (4)	86 to * — FXRT, FXRD
	4	1611	SCREW (2)	86 to * — FXRT, FXRD
	5	1651	SCREW (2)	84 & 85 — FXRT
		2779	SCREW (4)	86 to * — FXRT, FXRD
	6	2784	SCREW (2)	86 to * — FXRT
	7	2508	SCREW (4)	86 to * — FXRT, FXRD
	8	2648	SCREW (4)	84 to * — FXRT; 86 to * — FXRD
	9	2851	BOLT	84 & 85 — FXRT
		4371W	SCREW	86 to * — FXRT, FXRD
	10	2882W	BOLT (4)	84 & 85 — FXRT
	11	3802W	BOLT (4)	86 to * — FXRT, FXRD
	12	5207	WELLNUT (7)	84 to * — FXRT; 86 to * — FXRD
	13	5210	WELLNUT (4)	84 to * — FXRT; 86 to * — FXRD
	14	6019	WASHER	86 to * — FXRT, FXRD
	15	6053	WASHER (7)	84 to * — FXRT; 86 to * — FXRD
	16	6182W	WASHER (4)	86 to * — FXRT, FXRD
	17	6229W	WASHER (4)	84 & 85 — FXRT
	18	6333	WASHER (4; 8 — 86 & Later)	84 to * — FXRT; 86 to * — FXRD
	19	6701	WASHER	86 to * — FXRT, FXRD
	20	6703	WASHER (4; 12 — 86 & Later)	84 to * — FXRT; 86 to * — FXRD
	21	7038	LOCKWASHER	84 to * — FXRT; 86 to * — FXRD
	22	7042	LOCKWASHER (4)	84 & 85 — FXRT
	23	7230	LOCKWASHER (4)	84 & 85 — FXRT
	25	7609W	LOCKNUT (2)	84 & 85 — FXRT
	26	7626W	LOCKNUT (2)	86 to * — FXRT, FXRD
	27	7686	LOCKNUT (4; 8 — 86 & Later)	84 to * — FXRT; 86 to * — FXRD
	28	7688	NUT (4)	84 & 85 — FXRT
	29	7739	LOCKNUT (4; 8 — 86 & Later)	84 to * — FXRT; 86 to * — FXRD
	30	8151	SPEEDNUT (4)	86 to * — FXRT, FXRD
	31	8483	POP RIVET, flasher clip	84 to * — FXRT; 86 to * — FXRD
	32	8687	RIVET (4)	86 to * — FXRT, FXRD
	33	9859	WIRE TERMINAL, ring type — 5/16 dia. hole	84 to * — FXRT; 86 to * — FXRD
	34	9898	WIRE TERMINAL, flag type — #14-16 wire	84 to * — FXRT; 86 to * — FXRD
	35	9931	WIRE TERMINAL, female spade type (4)	84 to * — FXRT; 86 to * — FXRD
	36	9952	CLIP, flasher	84 to * — FXRT; 86 to * — FXRD
	37	10006	CABLE STRAP	84 to * — FXRT; 86 to * — FXRD
	38	14114—86	DECAL, windshield	86 to * — FXRT
		14133—86	DECAL, windshield (silver & blue)	86 to * — FXRD
		14134—86	DECAL, windshield (red & gold)	86 to * — FXRD
	39	53433—80	WASHER (nylon)(8)	84 to * — FXRT; 86 to * — FXRD
	40	57807—86	BRACKET, fairing support — right	86 to * — FXRT, FXRD
		57808—86	BRACKET, fairing support — left	86 to * — FXRT, FXRD
	41	58014—83	SEAL, between windshield and fairing	84 & 85 — FXRT
		58223—86	SEAL, windshield	86 to * — FXRT, FXRD
	42	58040—83	BRACKET, fairing mounting — upper	84 & 85 — FXRT
		58042—86	BRACKET, fairing mounting	86 to * — FXRT, FXRD
	43	58147—83	FILTER, air vent (2)	84 & 85 — FXRT
		58147—86	FILTER, vent (2)	86 to * — FXRT, FXRD
	44	58150—83	SUPPORT ASSEMBLY, lower	84 & 85 — FXRT
		57809—86	SUPPORT ASSEMBLY	86 to * — FXRT, FXRD
	45	58190—83	VENT LOUVER (2)	84 & 85 — FXRT
		58190—86	VENT LOUVER (2)	86 to * — FXRT, FXRD
	46	58212—86	DOOR, fairing (2)	86 to * — FXRT, FXRD

NOTE: PATENT PENDING

# WINDSHIELD AND FAIRING - FXRT, FXRD

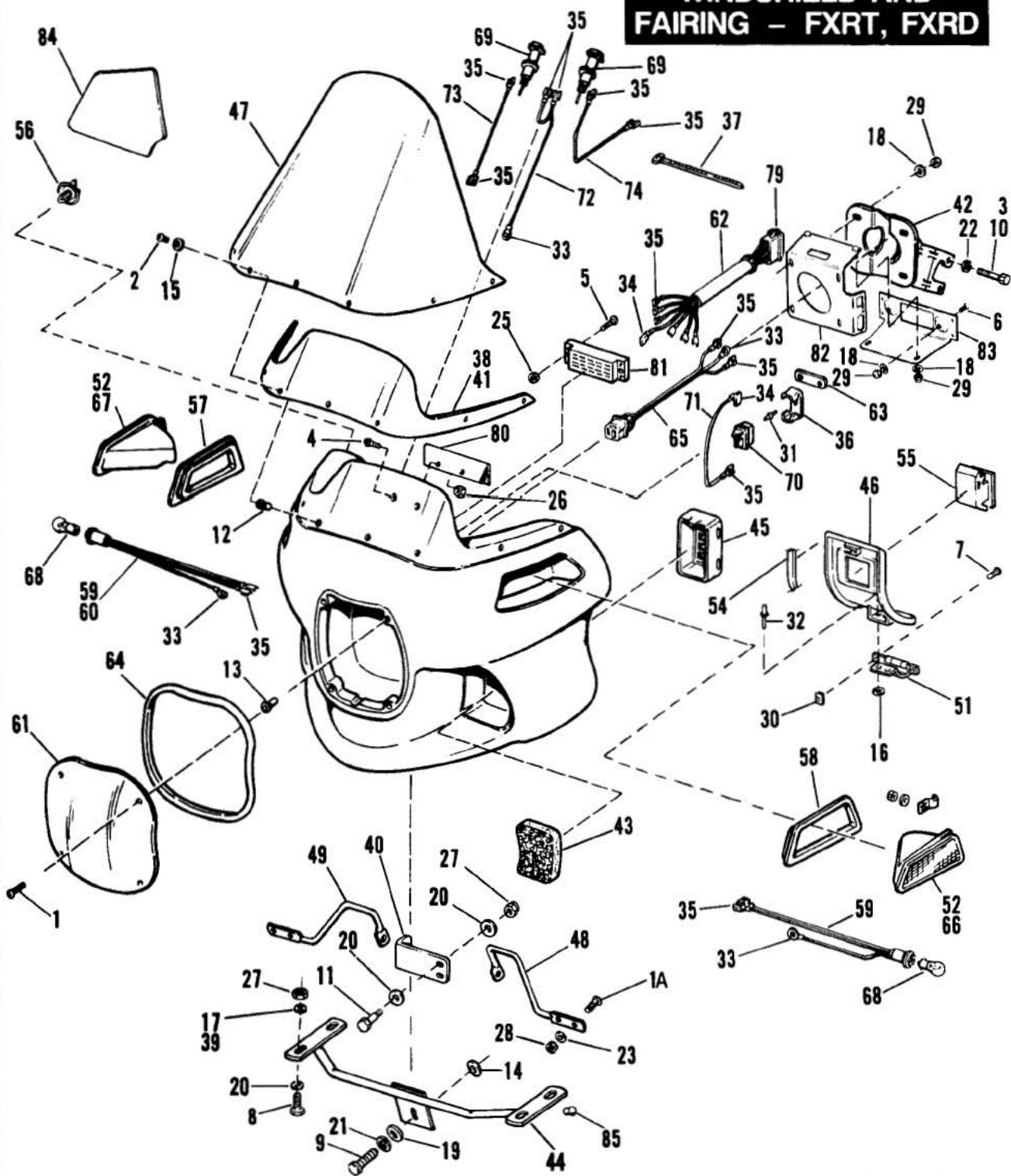

RETAIL PRICE	INDEX NO.	PART NO.	NAME	USED ON
			NOTE: For painted parts, see Dealer Accessory Guide.	
	47	58218-83	WINDSHIELD, 17" high	84 & 85 — FXRT
		58218-86	WINDSHIELD, 17" high	86 to * — FXRT, FXRD
		58219-86	WINDSHIELD, 22" high	86 to * — FXRT, FXRD
		58220-83	WINDSHIELD, 19" high	84 & 85 — FXRT
		58220-86A	WINDSHIELD, 19.5" high	86 to * — FXRT, FXRD
		58222-83	WINDSHIELD, 22" high	84 & 85 — FXRT
	48	58224-83	BRACE, left	84 & 85 — FXRT
	49	58227-83A	BRACE, right	84 & 85 — FXRT
		58265-86	BRACKET, power interrupt system	86 to * — FXRT, FXRD
	51	58454-86	HINGE, fairing door	86 to * — FXRT, FXRD
	52	58498-86	TURN SIGNAL, complete — left	84 to * — FXRT
		58499-86	TURN SIGNAL, complete — right	84 to * — FXRT
	54	58703-86	GASKET, fairing door (2)	86 to * — FXRT, FXRD
	55	58706-86	LATCH, door (2)	86 to * — FXRT, FXRD
	56	58708-86	CLIP, speaker grille (4)	86 to * — FXRT, FXRD
	57	58722-84	GASKET, right turn signal	84 to * — FXRT; 86 to * — FXRD
	58	58723-84	GASKET, left turn signal	84 to * — FXRT; 86 to * — FXRD
	59	67636-86	SOCKET, with wires & bulbs — turn signal (2) . . . N/A	86 to * — FXRT, FXRD
		67693-83	SOCKET, with wires & bulbs — left turn signal . . . N/A	84 & 85 — FXRT
	60	67694-83	SOCKET, with wires & bulbs — right turn signal	84 & 85 — FXRT
	61	67700-83	COVER, headlamp	84 to * — FXRT; 86 to * — FXRD
	62	67703-83	WIRING HARNESS, motorcycle to fairing	84 & 85 — FXRT
	63	67709-83	BRACKET, flasher mounting	84 to * — FXRT; 86 to * — FXRD
	64	67710-83	SEAL, headlamp cover	84 to * — FXRT; 86 to * — FXRD
	65	67714-83	WIRING HARNESS, terminal board to headlamp, includes items 21 & 23	84 & 85 — FXRT
		67715-86	WIRING HARNESS, terminal board to headlamp	86 to * — FXRT, FXRD
	66	68089-80	LENS, left turn signal (amber)	84 to * — FXRT; 86 to * — FXRD
	67	68092-80	LENS, right turn signal (amber)	84 to * — FXRT; 86 to * — FXRD
	68	68165-64	BULB, turn signal (2)	84 to * — FXRT; 86 to * — FXRD
	69	68465-83	INDICATOR LAMP, turn signal (2)	84 to * — FXRT; 86 to * — FXRD
	70	68543-64B	FLASHER, turn signal	84 to * — FXRT; 86 to * — FXRD
		68550-83	FLASHER, turn signal (HDI part only)	86 to * — FXRT, FXRD
	71	69512-83	WIRE, terminal block to flasher (orange)	84 to * — FXRT; 86 to * — FXRD
	72	69515-83	WIRING HARNESS, turn indicator lamps to ground (black)	N/A 84 & 85 — FXRT
	73	69516-83	WIRE, terminal board to right turn indicator (brown)	N/A 84 & 85 — FXRT
	74	69517-83	WIRE, terminal board to left turn indicator (violet)	N/A 84 & 85 — FXRT
		70147-86	WIRING HARNESS, instruments to terminal board	86 to * — FXRT, FXRD
		70150-86	WIRING HARNESS, terminal board to radio	86 to * — FXRT, FXRD
		72038-71	SOCKET, single pin	84 to * — FXRT; 86 to * — FXRD
	79	72278-74	HOUSING, socket terminal	84 to * — FXRT
	80	72310-70	BRACKET, terminal block	86 to * — FXRT, FXRD
	81	72312-73	TERMINAL BLOCK	84 to * — FXRT; 86 to * — FXRD
	82	76170-86	BRACKET, radio support	86 to * — FXRT, FXRD
	83	76173-86	BRACKET, radio mounting	86 to * — FXRT, FXRD
	84	76234-86	SPEAKER GRILLE — right	86 to * — FXRT, FXRD
		76236-86	SPEAKER GRILLE — left	86 to * — FXRT, FXRD
	85	90493-83	PLUG (2)	85 to * — FXRT; 86 to * — FXRD

# TOUR PAK - FXRD

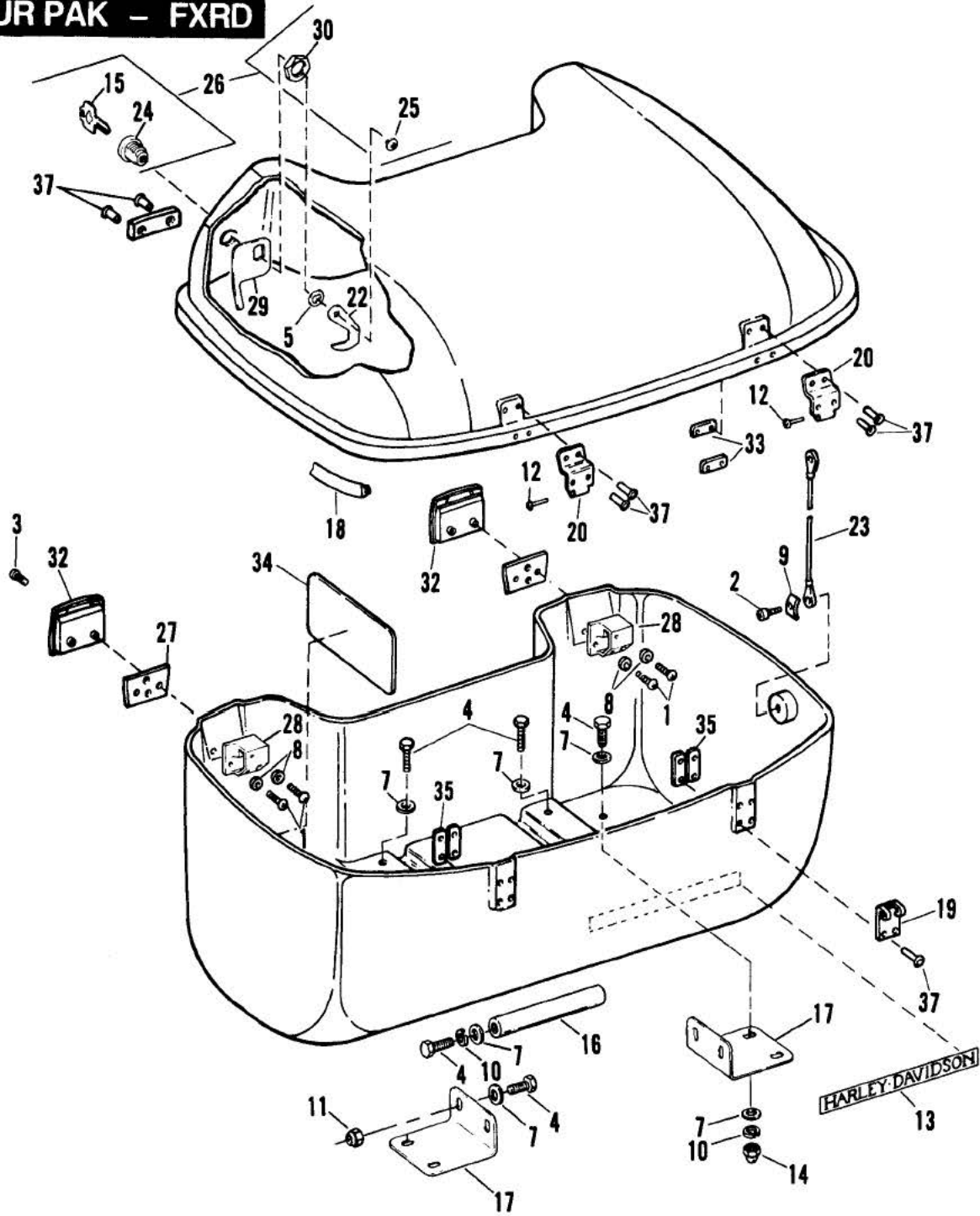



RETAIL PRICE	INDEX NO.	PART NO.	NAME	USED ON
	1	2779	SCREW (4)	86 to * — FXRD
	2	2903	SCREW (4) . . . . . N/A	86 to * — FXRD
	3	3524	SCREW (4)	86 to * — FXRD
	4	3787	BOLT (14)	86 to * — FXRD
	5	6055	SPRING WASHER, curved (2)	86 to * — FXRD
	7	6703	WASHER (18)	86 to * — FXRD
	8	6717	WASHER (4)	86 to * — FXRD
	9	6970	SPRING WASHER (4)	86 to * — FXRD
	10	7036	LOCKWASHER (6)	86 to * — FXRD
	11	7686	LOCKNUT (4)	86 to * — FXRD
	12	8502	RIVET (2)	86 to * — FXRD
	13	14118—86	DECAL (gold)	86 to * — FXRD
		14119—86	DECAL (silver)	86 to * — FXRD
	14	31589—80	ACORN NUT (4)	86 to * — FXRD
	15	48152—82	KEY	86 to * — FXRD
	16	53125—86	BRACE	86 to * — FXRD
	17	53126—86	BRACKET (2)	86 to * — FXRD
	18	53415—83	GASKET, cover	86 to * — FXRD
	19	53427—80	HINGE PLATE (2)	86 to * — FXRD
	20	53443—84	HINGE PLATE (2)	86 to * — FXRD
	22	53510—80	CAM HOOK (2)	86 to * — FXRD
	23	53564—82	CABLE (2)	86 to * — FXRD
	24	53580—82	LOCK (2)	86 to * — FXRD
	25	53582—82	SCREW, sems (2)	86 to * — FXRD
	26	53589—86	LOCKSET, includes items 15, 24, 25 & 30	86 to * — FXRD
	27	53615—85	SPACER (2)	86 to * — FXRD
	28	53616—85	CATCH (2)	86 to * — FXRD
	29	53617—85	LOCK GUIDE (2)	86 to * — FXRD
	30	84850—67	NUT, lock bracket (2)	86 to * — FXRD
	32	90649—85	BODY CATCH (2)	86 to * — FXRD
	33	90688—85	BACKING PLATE (2)	86 to * — FXRD
	34	90821—74A	LABEL, load limit	86 to * — FXRD
	35	90964—63	BACKING PLATE (4)	86 to * — FXRD
	37	90967—64	RIVET (16)	86 to * — FXRD

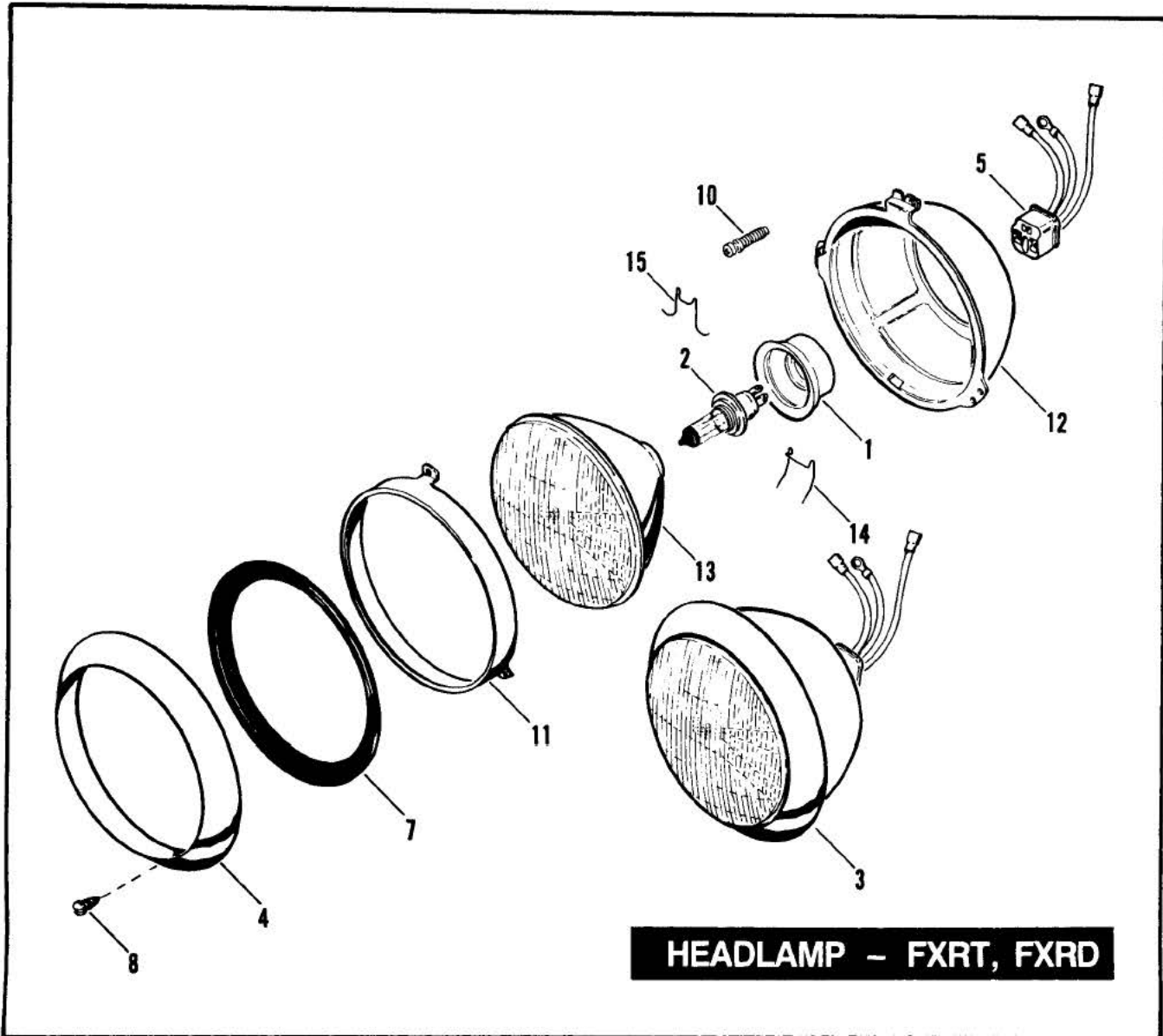

**HEADLAMP — FXRT, FXRD**

**RS33**

RETAIL PRICE	INDEX NO.	PART NO.	NAME	USED ON
	1	67696—81	BOOT, halogen headlamp	84 to * — FXRT; 86 to * — FXRD
	2	67697—81	BULB, halogen	84 to * — FXRT; 86 to * — FXRD
	3	67701—83A	HEADLAMP ASSEMBLY, complete (Halogen)	84 to * — FXRT; 86 to * — FXRD
	4	67712—83	RING	84 to * — FXRD; 86 to * — FXRT
	5	67714—83	WIRING HARNESS, terminal board to headlamp	84 to * — FXRT; 86 to * — FXRD
	7	67716—60A	GASKET, headlamp door	84 to * — FXRT; 86 to * — FXRD
	8	67718—60A	SCREW, headlamp door	84 to * — FXRT; 86 to * — FXRD
	10	67724—71	ADJUSTING SCREW (2)	84 to * — FXRT; 86 to * — FXRD
	11	67726—71	RETAINING RING (3/4 inch deep)	84 to * — FXRT; 86 to * — FXRD
	12	67732—71	MOUNTING DISC (no slot in I.D.)	84 to * — FXRT; 86 to * — FXRD
	13	67755—81	HEADLAMP, less bulb — with boot	84 to * — FXRT; 86 to * — FXRD
	14	67778—60	TOP SPRING, headlamp door	84 to * — FXRT; 86 to * — FXRD
	15	67780—60	BOTTOM SPRING, headlamp door	84 to * — FXRT; 86 to * — FXRD

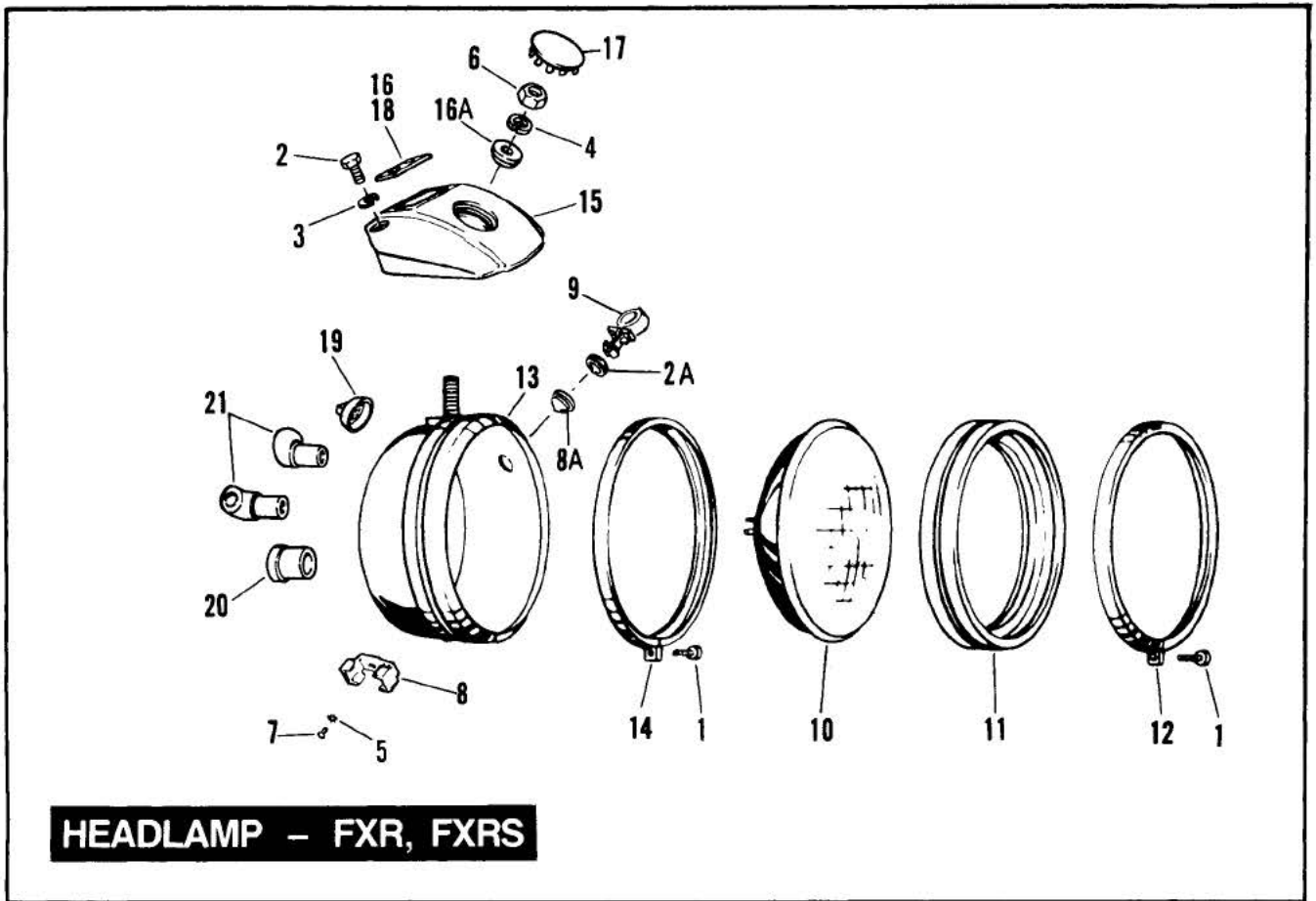

**HEADLAMP – FXR, FXRS**

**HEADLAMP — FXR, FXRS**

**RS33A**

RETAIL PRICE	INDEX NO.	PART NO.	NAME	USED ON
	1	1203	SCREW (2)	84 to * — FXRS; 86 to * — FXR
	2	2871W	BOLT (2)	84 to * — FXRS; 86 to * — FXR
	2A	6265	WASHER	84 to * — FXRS
	3	7041	LOCKWASHER (2)	84 to * — FXRS; 86 to * — FXR
	4	7068	LOCKWASHER	84 to * — FXRS; 86 to * — FXR
	5	7220	LOCKWASHER	84 to * — FXRS; 86 to * — FXR
	6	7880	NUT	84 to * — FXRS; 86 to * — FXR
	7	8519	RIVET	84 to * — FXRS; 86 to * — FXR
	8	9952	CLIP	84 to * — FXRS; 86 to * — FXR
	8A	11448	PLUG	86 to * — FXR
	9	56073—83	RETAINER, cable	84 to * — FXRS
	10	67698—81A	HEADLAMP, halogen	84 to * — FXRS; 86 to * — FXR
	11	67719—63	MOUNTING RING	84 to * — FXRS; 86 to * — FXR
	12	67725—63	MOULDING, outer	84 to * — FXRS; 86 to * — FXR
	13	67743—84	HOUSING, headlamp	84 to * — FXRS; 86 to * — FXR
	14	67744—75	MOULDING, inner	84 to * — FXRS; 86 to * — FXR
	15	67805—86	BRACKET	86 to * — FXR, FXRS
		67809—75	BRACKET	84 & 85 — FXRS
	16	67807—86	TRIM	86 to * — FXR
	16A	67815—59A	WASHER	84 to * — FXRS; 86 to * — FXR
	17	67830—59	PLUG, headlamp bracket	84 to * — FXRS; 86 to * — FXR
	18	67834—83	TRIM	84 to * — FXRS
	19	67839—74	BOOT, headlamp connector	84 to * — FXRS; 86 to * — FXR
	20	72501—74	BUSHING, straight	84 to * — FXRS; 86 to * — FXR
	21	72502—74	BUSHING, angle (2)	84 to * — FXRS; 86 to * — FXR

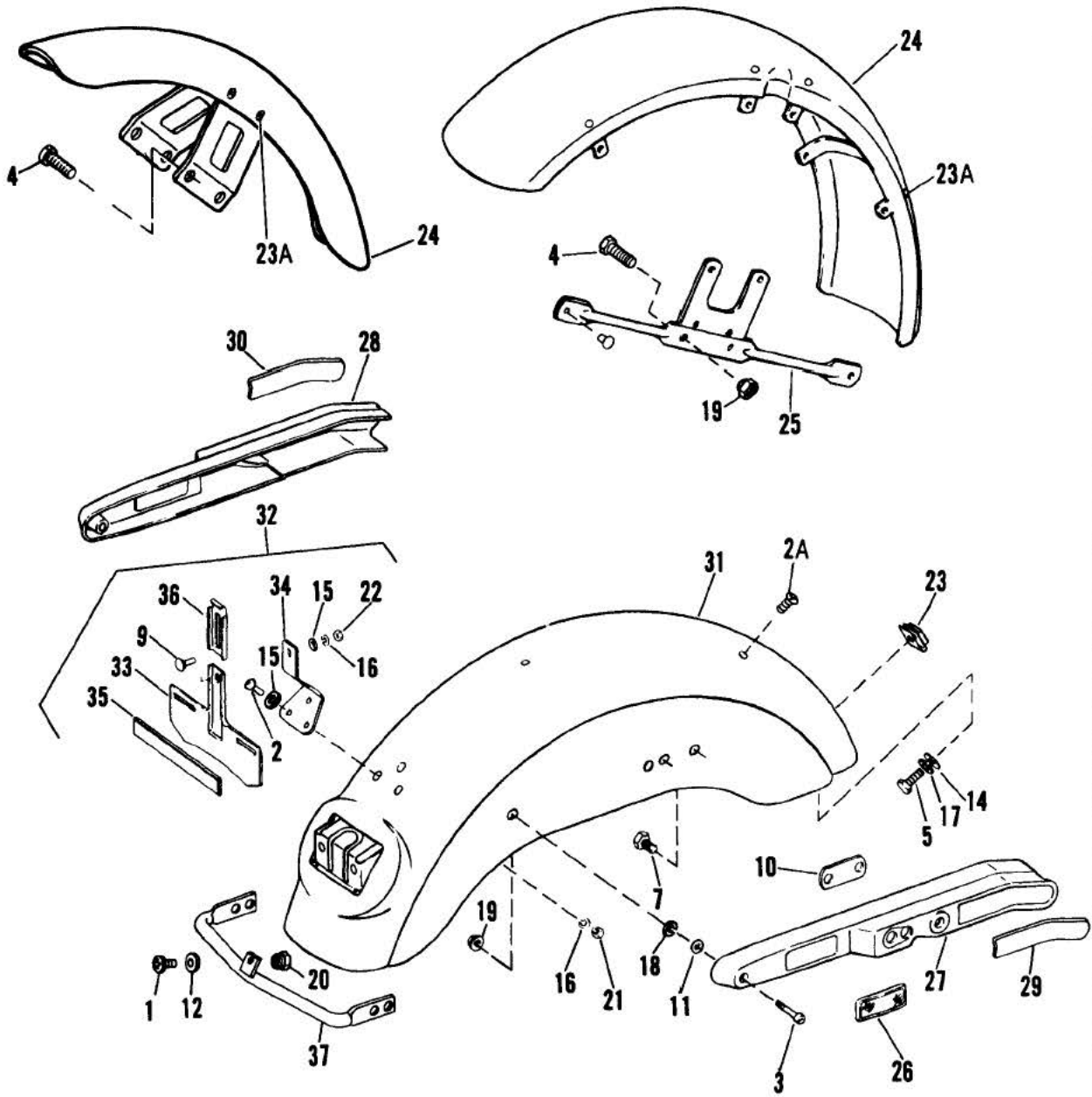

**FENDERS AND LICENSE PLATE BRACKETS**

# FENDERS AND LICENSE PLATE BRACKETS

RS34

RETAIL PRICE	INDEX NO.	PART NO.	NAME	USED ON
	1	2420	SCREW .....	84 — FXRT
		2607	SCREW .....	85 to * — FXRT; 86 to * — FXRD
	2	2774	SCREW (3) .....	84 to * — All Models
	2A	2824W	SCREW (2) .....	86 to * — FXR
	3	2887W	BOLT (2) .....	84 to * — FXRT; 86 to * — FXRD
	4	3210	SCREW (6) .....	84 to * — All Models
	5	3445	BOLT .....	84 to * — All Models
	7	3785	BOLT (2) .....	84 to * — All Models
	9	5403B	BOLT .....	84 to * — All Models
	10	5713	SPACER (2) .....	84 to * — FXRS; 86 to * — FXR
	11	6109	WASHER (2) .....	84 & 85 — FXRS
	12	6410	WASHER .....	84 to * — FXRT; 86 to * — FXRD
	14	6702	WASHER .....	84 to * — All Models
	15	6703	WASHER (4) .....	84 to * — All Models
	16	7036	LOCKWASHER (4) .....	84 to * — All Models
	17	7041	LOCKWASHER .....	84 & 85 — FXRS, FXRT
	18	7130W	LOCKWASHER (2) .....	84 & 85 — FXRS, FXRT
	19	7531	NUT (6) .....	84 to * — All Models
	20	7686	LOCKNUT .....	84 to * — FXRT; 86 to * — FXRD
	21	7688	NUT (3) .....	84 to * — All Models
	22	7689W	NUT .....	84 to * — All Models
	23	8102	CAGE NUT .....	84 to * — All Models
	23A	8519	RIVET (8; 4 — FXR) .....	84 to * — FXRS; 86 to * — FXR
	24	58998—83	FRONT FENDER (prime) .....	86 to * — FXR, FXRS
		59007—84	FRONT FENDER (prime) .....	84 to * — FXRS, FXRT; 86 to * — FXRD
	25	59111—74	FENDER BRACE (2) .....	84 to * — FXRS, FXRT; 86 to * — FXRD
	26	59263—79	REFLECTOR (red)(2) .....	84 to * — FXRS; 86 to * — FXR
	27	59500—81	SUPPORT, rear fender — right .....	86 to * — FXR, FXRS
		59500—84	SUPPORT, rear fender — right .....	84 & 85 — FXRS
		59504—84	SUPPORT, rear fender — right .....	84 to * — FXRT; 86 to * — FXRD
	28	59501—81	SUPPORT, rear fender — left .....	86 to * — FXR, FXRS
		59501—84	SUPPORT, rear fender — left .....	84 & 85 — FXRS
		59505—84	SUPPORT, rear fender — left .....	84 to * — FXRT; 86 to * — FXRD
	29	59502—84	TRIM, rear fender support — right .....	84 & 85 — FXRS
	30	59503—84	TRIM, rear fender support — left .....	84 & 85 — FXRS
	31	59573—83	REAR FENDER (prime) .....	84 to * — FXRT; 86 to * — FXRD
		59634—81A	REAR FENDER (prime) .....	84 to * — FXRS; 86 to * — FXR
	32	59983—75	LICENSE BRACKET ASSEMBLY .....	84 to * — All Models
	33	59984—73	BRACKET, license plate .....	84 to * — All Models
	34	59986—75	SUPPORT, license plate bracket .....	84 to * — All Models
	35	59988—72	REFLECTOR, license plate bracket (red) .....	84 to * — All Models
	36	60001—55	CLAMP, license plate bracket .....	84 to * — All Models
	37	90488—83	SUPPORT BRACKET, saddlebags .....	84 to * — FXRT; 86 to * — FXRD

# PRIMARY HOUSING – 1984

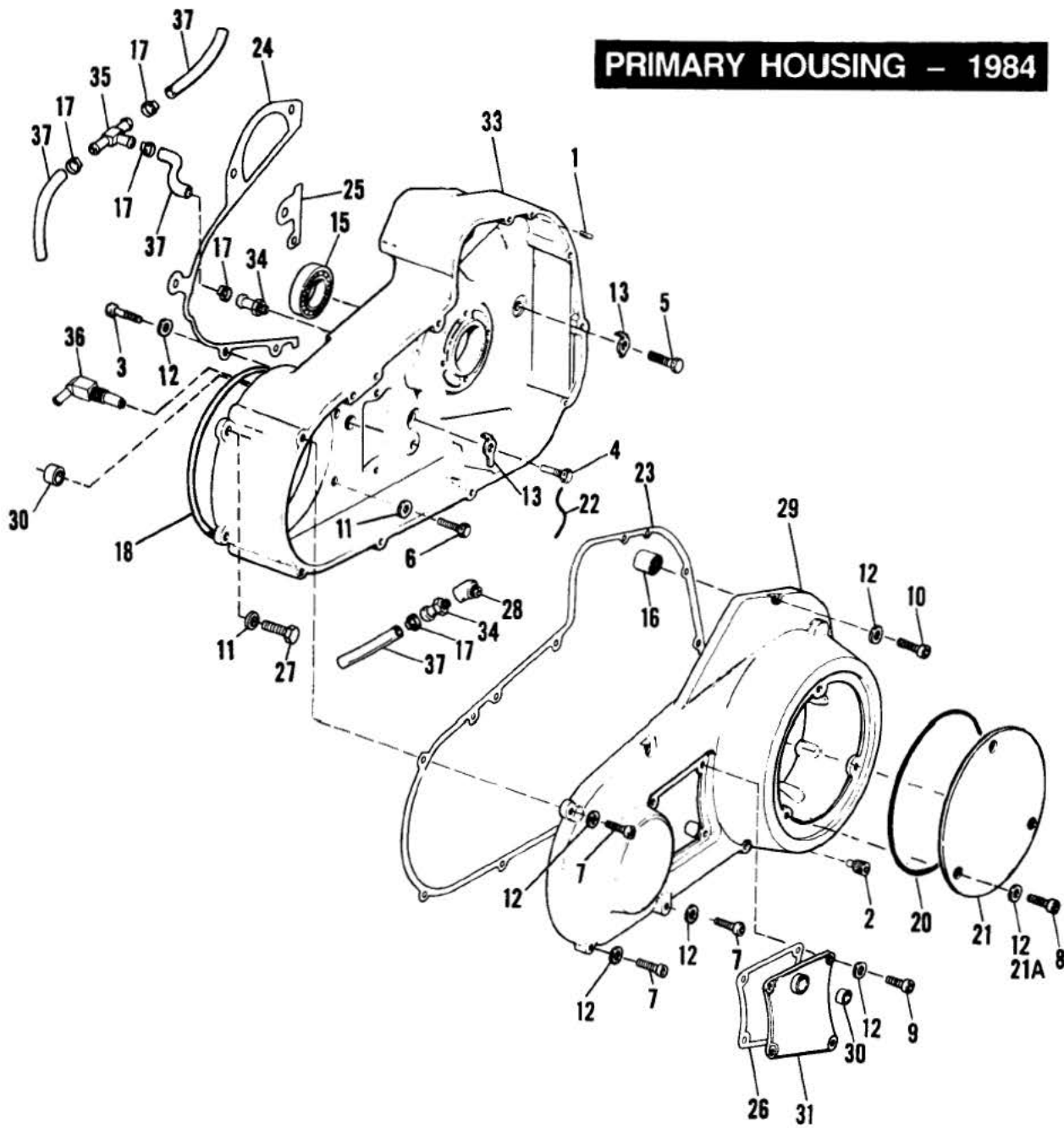

RETAIL PRICE	INDEX NO.	PART NO.	NAME	USED ON
	1	221	PIN (2)	84 — FXRS, FXRT
	2	718	PLUG, primary cover (magnetic)	84 — FXRS, FXRT
	3	2871W	BOLT (2)	84 — FXRS, FXRT
	4	4023	BOLT, drilled hd.	84 — FXRS, FXRT
	5	4024	BOLT, drilled hd.	84 — FXRS, FXRT
	6	4026	BOLT, drilled hd.	84 — FXRS, FXRT
	7	4740	SCREW, w/lockpatch (9)	84 — FXRS, FXRT
	8	4811	SCREW, w/lockpatch (3)	Early 84 — FXRS, FXRT
	9	4812	SCREW, w/lockpatch (4; 7 — Late 84)	84 — FXRS, FXRT
	10	4814	SCREW, w/lockpatch	84 — FXRS, FXRT
	11	6016	WASHER (4)	84 — FXRS, FXRT
	12	6099	WASHER (19; 16 — Late 84)	84 — FXRS, FXRT
	13	7402	LOCKPLATE (2)	84 — FXRS, FXRT
	15	8975	BALL BEARING	Early 84 — FXRS, FXRT
		8980	BALL BEARING	Late 84 — FXRS, FXRT
	16	9063	NEEDLE BEARING	84 — FXRS, FXRT
	17	10080	CLAMP (5)	84 — FXRS, FXRT
	18	11147	O-RING, primary housing cover	84 — FXRS, FXRT
	20	25416—70	GASKET, clutch cover	Early 84 — FXRS, FXRT
		25416—84	O-RING, clutch cover	Late 84 — FXRS, FXRT
	21	25414—70A	COVER, clutch (polished)	84 — FXRS, FXRT
	21A	31433—84A	WASHER, clutch cover (nylon)(3)	Late 84 — FXRS, FXRT
	22	33042—80	SAFETY WIRE (2)	84 — FXRS, FXRT
	23	34901—79B	GASKET, housing cover	84 — FXRS, FXRT
	24	34902—79A	GASKET, primary housing	84 — FXRS, FXRT
	25	34903—79	GASKET, transmission to primary housing	84 — FXRS, FXRT
	26	34906—79A	GASKET, inspection cover	84 — FXRS, FXRT
	27	43868—72	SCREW (2)	84 — FXRS, FXRT
	28	60604—80	FITTING, breather hose	84 — FXRS, FXRT
	29	60605—79B	COVER, primary housing (w/9063 BEARING)(polished)	84 — FXRS, FXRT
	30	60629—82	BUSHING (2)	84 — FXRS, FXRT
	31	60642—82	INSPECTION COVER	Early 84 — FXRS, FXRT
		60642—84	INSPECTION COVER	Late 84 — FXRS, FXRT
	33	60657—84	PRIMARY HOUSING ASSEMBLY	Early 84 — FXRS, FXRT
		60662—84	PRIMARY HOUSING ASSEMBLY	Late 84 — FXRS, FXRT
	34	63533—41	FITTING, oil line (2)	84 — FXRS, FXRT
	35	63580—66A	TEE FITTING, oil line	Early 84 — FXRS, FXRT
	36	63585—82	FITTING, front chain oiler	84 — FXRS, FXRT
		NOTE: Hose is sold only in bulk length under the following part number. Cut to required lengths.		
	37	63500—68	HOSE, 3/8 I.D. x 5/8 O.D. reinforced rubber (25 ft. lg.)	84 — FXRS, FXRT

**PRIMARY HOUSING  
- 1985 & LATER**

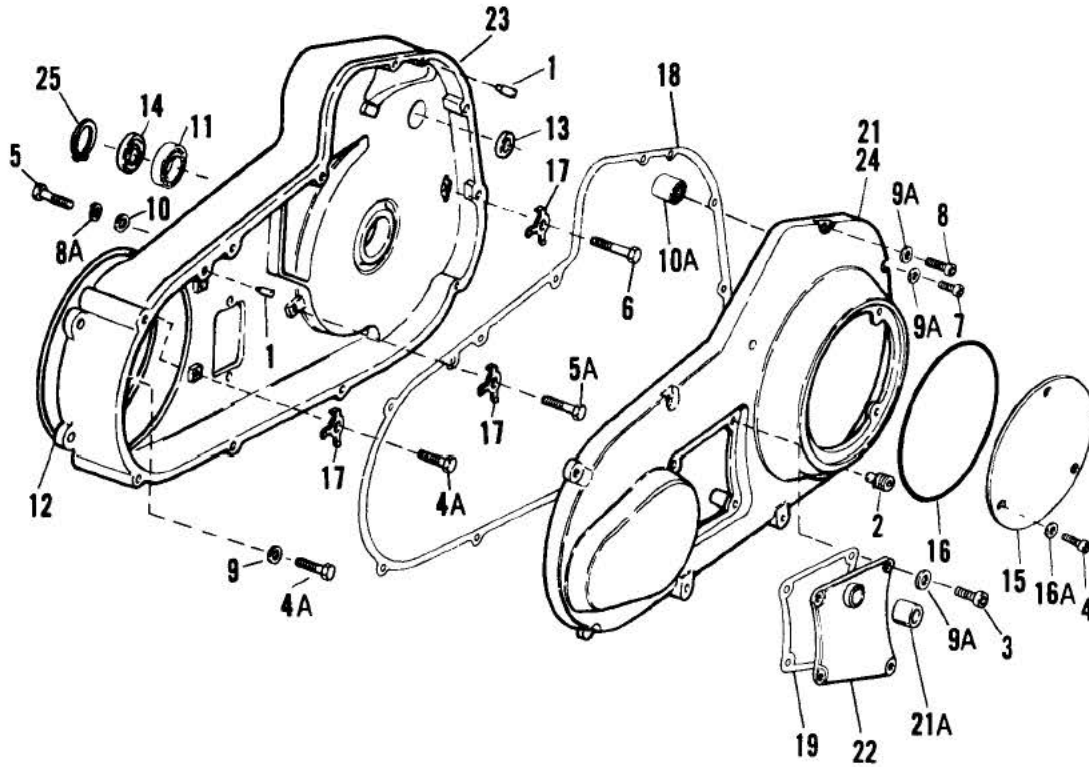



RETAIL PRICE	INDEX NO.	PART NO.	NAME	USED ON
	1	221	PIN (2)	85 to * — All Models
	2	739	PLUG, primary cover (magnetic)	85 to * — All Models
	3	923	SCREW (4)	85 to * — All Models
	4	924	SCREW (3)	85 to * — All Models
	4A	2818	BOLT (4)	85 to * — All Models
	5	2871W	BOLT	86 to * — All Models
	5A	4068	BOLT	85 to * — All Models
	6	4086	BOLT	85 to * — All Models
	7	4718	SCREW (5)	85 to * — All Models
	8	4740	SCREW (5)	85 to * — All Models
	8A	6016	WASHER (2 — 84 & 85)	85 to * — All Models
	9	6324W	WASHER (2)	86 to * — All Models
	9A	6099	WASHER (10)	85 to * — All Models
	10	7127	LOCKWASHER	86 to * — All Models
	10A	9063	NEEDLE BEARING	85 to * — All Models
	11	9135	BEARING	85 to * — All Models
	12	11147	O-RING, primary housing cover	85 to * — All Models
	13	12051	OIL SEAL	85 to * — All Models
	14	12052	OIL SEAL	85 to * — All Models
	15	25414—70A	COVER, clutch	85 to * — All Models
	16	25416—84	O-RING, clutch cover	85 to * — All Models
	16A	31433—84A	WASHER, clutch cover (3)	85 to * — All Models
	17	33318—85	LOCKING TAB (4)	85 to * — All Models
	18	34901—85	GASKET, housing cover	85 to * — All Models
	19	34906—85	GASKET, inspection cover	85 to * — All Models
	21	60605—85	COVER, primary housing	N/A 85 to * — All Models
	21A	60629—82	BUSHING (2)	85 to * — All Models
	22	60642—85	INSPECTION COVER	85 to * — All Models
	23	60662—85A	PRIMARY HOUSING ASSEMBLY	85 — FXRS, FXRT
		60662—86A	PRIMARY HOUSING ASSEMBLY	86 to * — All Models
	24	60664—85B	COVER ASSEMBLY, includes items 2, 10A & 21	85 to * — All Models
	25	60678—85	RETAINING RING (2)	85 to * — All Models

# FUEL TANK

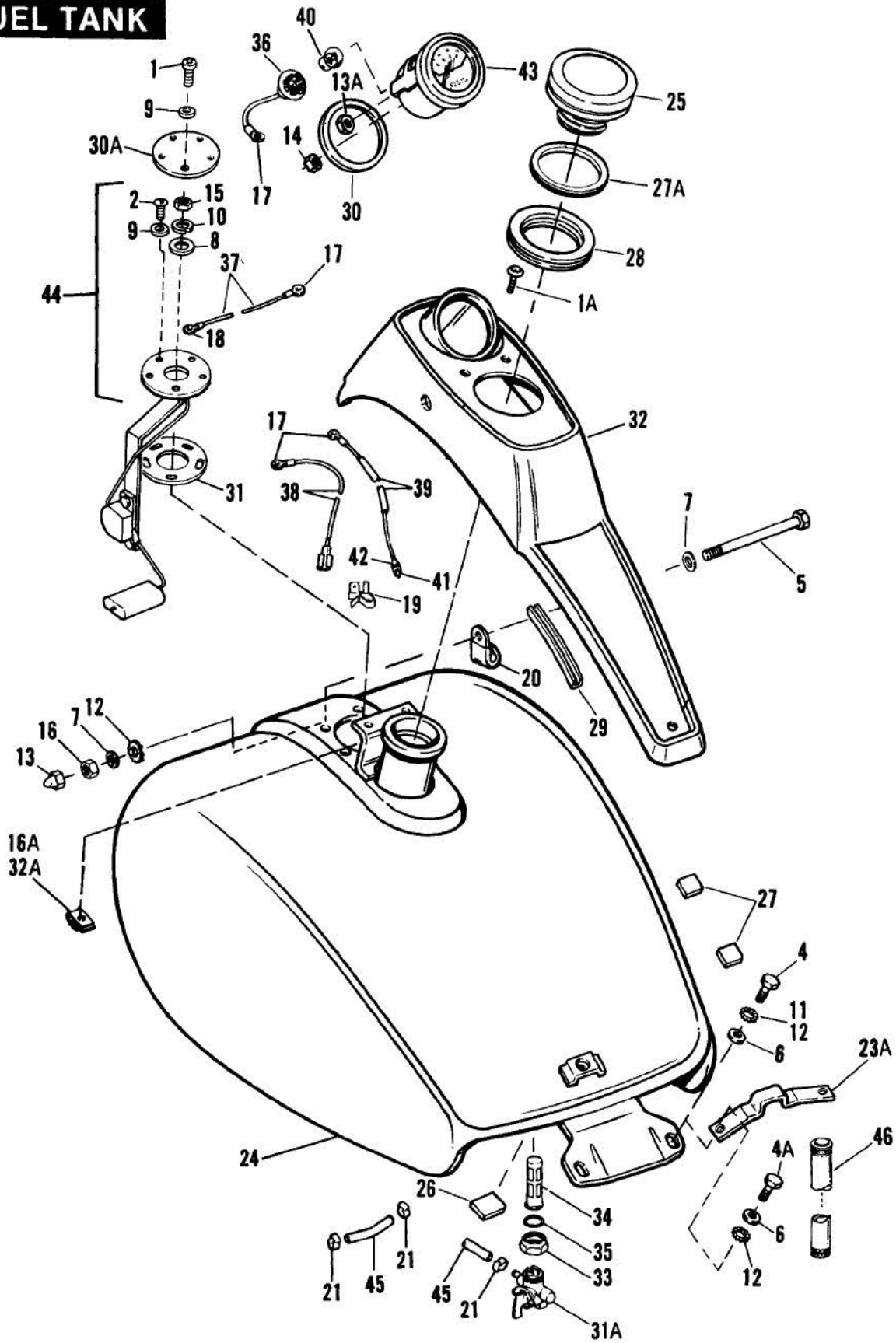

RETAIL PRICE	INDEX NO.	PART NO.	NAME	USED ON
	1	907	SCREW (5)	86 to * — FXR
	1A	919	SCREW (2)	84 & 85 — FXRS, FXRT
		923	SCREW (2)	86 to * — All Models
	2	1309	SCREW (5)	84 to * — FXRS, FXRT, FXRD
	4	3987	BOLT (2)	84 to * — FXRS, FXRT; 86 to * — FXRD
	4A	3991	BOLT	86 to * — FXR
	5	4067	BOLT	84 — FXRT; 86 to * — FXRT, FXRD
		4100HW	BOLT	84 to * — FXRS; 86 to * — FXR
	6	6109	WASHER (3)	84 to * — FXRS; 86 to * — FXR
	7	6702	WASHER (2 — 86 & Later FXRT & FXRD)	84 to * — All Models
	8	6716	WASHER	84 to * — FXRS, FXRT; 86 to * — FXRD
	9	6759	WASHER (nylon)(5)	84 to * — All Models
	10	7069	LOCKWASHER	84 to * — FXRS, FXRT; 86 to * — FXRD
	11	7229W	LOCKWASHER (2)	84 — FXRS
	12	7232	LOCKWASHER (2)	84 & 85 — FXRS, FXRT; 86 to * — FXR, FXRS
	13	7507	ACORN NUT (chrome)	84 to * — FXRS; 86 to * — FXR
	13A	7590	NUT (3)	86 to * — FXRS, FXRT, FXRD
	14	7608	NUT (2)	84 to * — FXRS, FXRT; 86 to * — FXRD
	15	7638	NUT (2)	84 to * — FXRS, FXRT; 86 to * — FXRD
	16	7739	LOCKNUT	84 to * — FXRT; 86 to * — FXRD
	16A	7743	SPEED NUT (2)	86 to * — All Models
	17	9856	WIRE TERMINAL (3)	84 to * — FXRS, FXRT; 86 to * — FXRD
	18	9857	WIRE TERMINAL	84 to * — FXRS, FXRT; 86 to * — FXRD
	19	9894	CLIP, ground wire	84 to * — FXRS, FXRT; 86 to * — FXR, FXRD
	20	9988	CLIP, throttle cables	84 to * — All Models
	21	10014	CLAMP (4)	84 to * — All Models
	23A	52107—86	BRACKET, seat	86 to * — FXR
	24	61044—82B	TANK ASSEMBLY (prime)	84 to * — All Models
	25	61060—82A	FILLER CAP	84 to * — All Models
	26	61079—82	PAD	84 to * — All Models
	27	61090—82	PAD (2)	Early 84 — FXRS, FXRT
	27A	61109—85	GASKET, filler cap	84 to * — All Models
	28	61112—82	BOOT	84 to * — All Models
	29	61115—82	TRIM (2)	84 to * — FXRS, FXRT; 86 to * — FXRD
		61117—86	TRIM	86 to * — FXR
	30	61311—82	GASKET, fuel gauge	84 to * — FXRS, FXRT; 86 to * — FXRD
	30A	61321—80	PLATE, cover	86 to * — FXR
	31	61322—80A	GASKET, fuel sending unit	84 to * — FXRS, FXRT; 86 to * — FXRD
	31A	61335—83	VALVE, body	84 to * — All Models
	32	61411—82	CONSOLE, tank (chrome)	84 to * — FXRS, FXRT; 86 to * — FXRD
		61413—86	CONSOLE, tank (black wrinkle)	86 to * — FXR
	32A	62044—82	NUT AND RETAINER (2)	84 & 85 — FXRS, FXRT
	33	62161—75	NUT	84 to * — All Models
	34	62166—81	FILTER	84 to * — All Models
	35	62172—75	GASKET, fuel filter	84 to * — All Models
	36	69540—78	SOCKET, with wire	84 to * — FXRS, FXRT; 86 to * — FXRD
	37	69617—82	WIRE, sending unit to gauge	84 to * — FXRS, FXRT; 86 to * — FXRD
	38	69618—82A	WIRE, fuel gauge — ground	84 to * — FXRS, FXRT; 86 to * — FXRD
	39	69619—82	WIRE, fuel gauge to harness	84 to * — FXRS, FXRT; 86 to * — FXRD
	40	71099—74	BULB, fuel gauge	84 to * — FXRS, FXRT; 86 to * — FXRD
	41	72039—71	PIN, single socket	84 to * — FXRS, FXRT; 86 to * — FXRD
	42	72043—71	CONNECTOR, single pin	84 to * — FXRS, FXRT; 86 to * — FXRD
	43	75033—82	FUEL GAUGE (86 — k.p.h. graphics)	84 to * — FXRS, FXRT; 86 to * — FXRD
		75039—86	FUEL GAUGE (86 — m.p.h. graphics)	86 to * — FXRS, FXRT, FXRD
	44	75034—82	SENDING UNIT	84 to * — FXRS, FXRT; 86 to * — FXRD
NOTE: Hose or insulator is sold in bulk length under the following part numbers. Cut to required length.				
	45	63501—68	HOSE, 1/4 I.D. x 5/8 O.D. reinforced rubber (25 ft. lg.)	84 to * — All Models
	46	63505—84	INSULATOR, 1/2 I.D. (nylon)(8 ft. lg.)	84 to * — All Models

# FUEL TANK TRIM

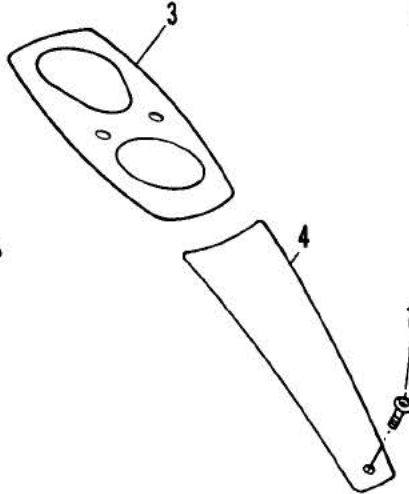

# FUEL TANK TRIM

RS36A

RETAIL PRICE	INDEX NO.	PART NO.	NAME	USED ON
	1	3651	SCREW .....	86 to * — FXR
		3652	SCREW .....	84 to * — FXRS, FXRT; 86 to * — FXRD
	2	14004—82	TRIM (silver & black)(2) .....	84 — FXRS, FXRT
		14005—82	TRIM (gold & black)(2) .....	84 — FXRS, FXRT
		14006—82	TRIM (gold & brown)(2) .....	84 — FXRS, FXRT
		14072—84	TRIM, right (gold & black) .....	85 — FXRS, FXRT
		14072—86	TRIM, right (gold & black) .....	86 to * — FXRS, FXRT
		14073—84	TRIM, left (gold & black) .....	85 — FXRS, FXRT
		14073—86	TRIM, left (gold & black) .....	86 to * — FXRS, FXRT
		14105—85	TRIM, left (silver & black) .....	85 — FXRS, FXRT
		14105—86	TRIM, left (silver & black) .....	86 to * — FXRS, FXRT
		14106—85	TRIM, right (silver & black) .....	85 — FXRS, FXRT
		14106—86	TRIM, right (silver & black) .....	86 to * — FXRS, FXRT
	3	14055—84	TRIM, upper - console (black) .....	84 to * — FXRS, FXRT; 86 to * — FXRD
	4	14056—84	TRIM, lower - console (black) .....	84 to * — FXRS, FXRT; 86 to * — FXRD
	5	14067—84	DECAL (black/red/silver) .....	84 — FXRS, FXRT
		14068—84	DECAL (black/red/gold) .....	84 — FXRS, FXRT
	6	14077—86	DECAL (blue & silver)(2) .....	86 to * — FXRD
		14078—86	DECAL (red & gold)(2) .....	86 to * — FXRD
	7	14122—86	DECAL (grey & orange)(2) .....	86 to * — FXR
	8	14135—86	DECAL, left, "Liberty" .....	86 to * — FXRS
		14136—86	DECAL, right, "Liberty" .....	86 to * — FXRS

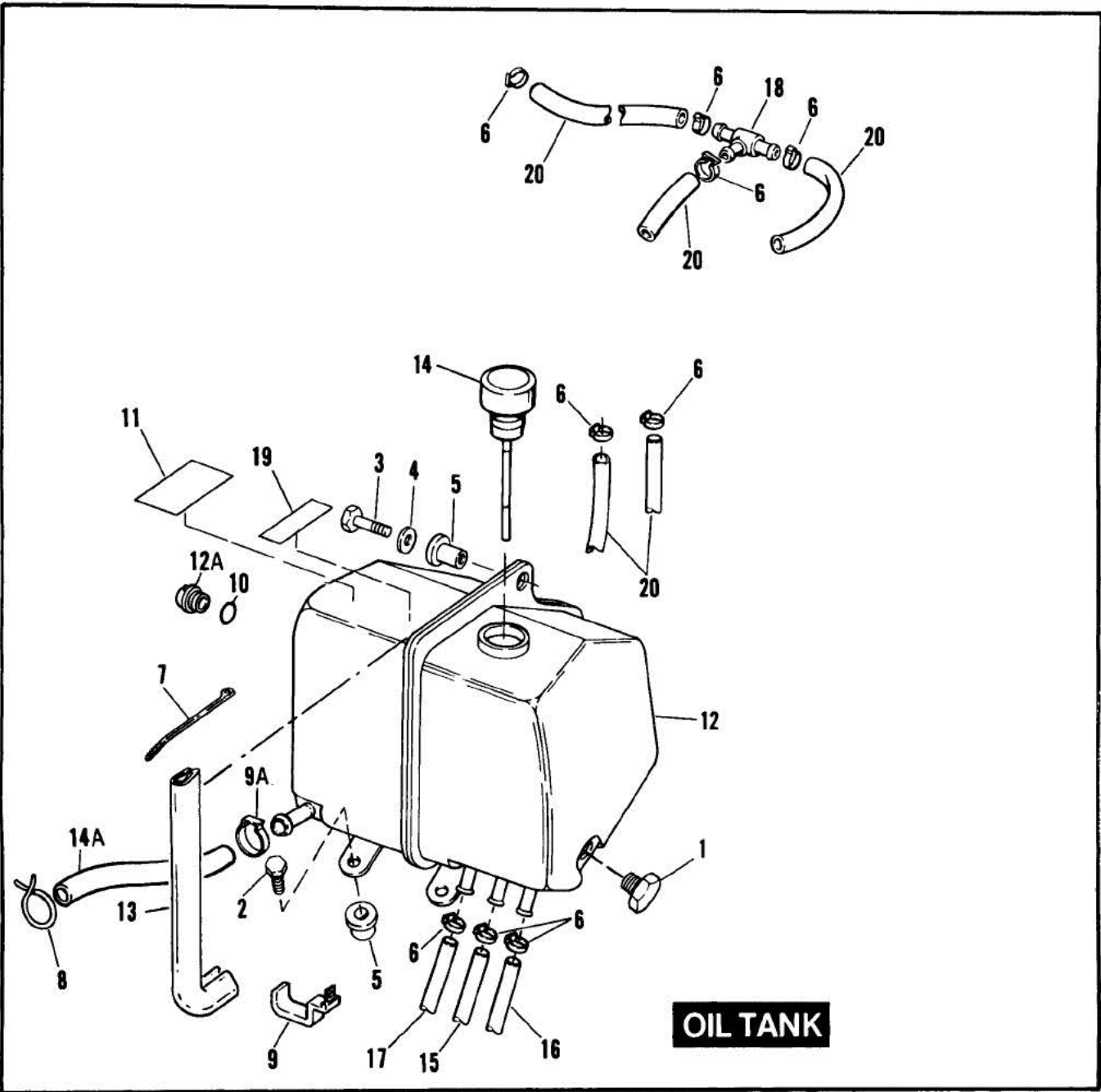

RETAIL PRICE	INDEX NO.	PART NO.	NAME	USED ON
	1	706A	PLUG, drain	84 & 85 — FXRS, FXRT
	2	2538	BOLT (2)	84 & Early 85 — FXRS, FXRT
		2607	SCREW (2)	Late 85 to * — All Models
	3	2551W	BOLT	84 to * — All Models
	4	6703	WASHER	84 to * — All Models
	5	8099	WELLNUT (3)	84 to * — All Models
		10080	CLAMP (10 — Early 84; 8)	84 to * — All Models
	7	10039	CABLE STRAP, fuel lines	Early 84 — FXRS, FXRT
	8	10049	CLAMP, drain hose	86 to * — All Models
	9	10070	CLAMP, feed line	85 to * — All Models
		10084	CLAMP, return & vent lines	85 to * — All Models
	9A	10086	CLAMP, drain hose	86 to * — All Models
	10	11132	O-RING	86 to * — FXR
	11	14101—84	LABEL, instruction	84 to * — All Models
	12	62406—81	OIL TANK (black)	84 & 85 — FXRS, FXRT
		62406—86	OIL TANK (black)	86 to * — FXR
		62414—86	OIL TANK (black)	86 to * — FXRS, FXRT, FXRD
	12A	62460—86	SIGHT GLASS, oil level	86 to * — FXR
	13	62540—83	TRIM STRIP, oil tank	84 to * — FXRS, FXRT
	14	62637—84	FILLER CAP	84 to * — FXRS, FXRT
	14A	63504—83	HOSE, oil drain	86 to * — All Models
	15	63557—84	HOSE, oil tank outlet to oil pump	Late 84 to * — FXRS, FXRT
	16	63559—84	HOSE, crankcase to oil tank vent	Late 84 to * — FXRS, FXRT
	17	63563—84	HOSE, oil filter outlet to tank vent	Late 84 — FXRS, FXRT
		63563—85	HOSE, oil filter outlet to oil tank vent	85 to * — FXRS, FXRT
	18	63580—66A	TEE FITTING	Early 84 — FXRS, FXRT
	19	66042—79A	WARNING LABEL	84 to * — FXRS, FXRT
	20	63500—68	NOTE: Hose is sold only in bulk length under the following part number. Cut to required lengths. HOSE, 3/8 I.D. x 5/8 O.D. reinforced rubber (25 ft. lg.)	Early 84 — FXRS, FXRT

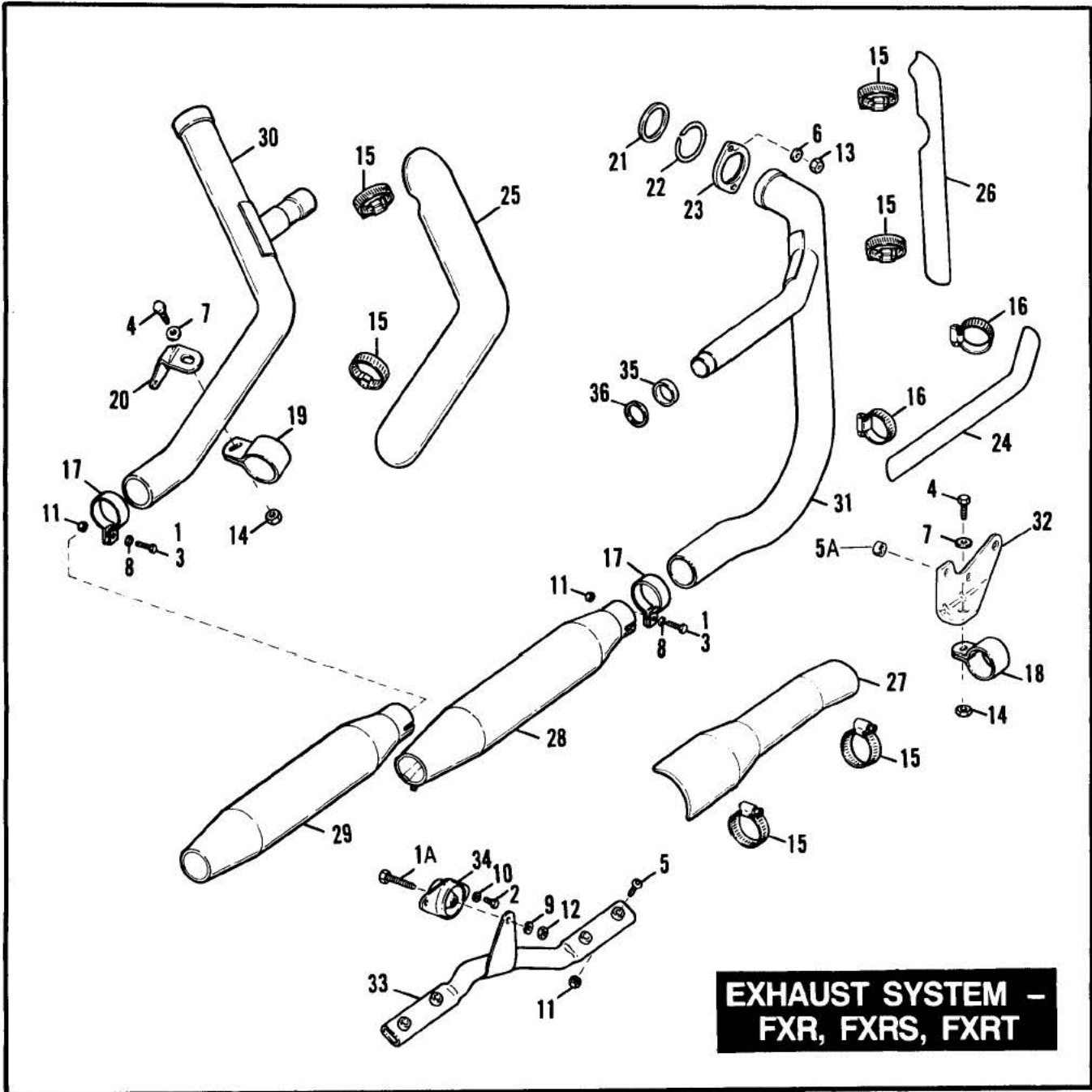



RETAIL PRICE	INDEX NO.	PART NO.	NAME	USED ON
	1	2818	BOLT (2)	86 to * — FXR, FXRS, FXRT
	1A	2887W	BOLT	84 to * — FXRS, FXRT; 86 to * — FXR
	2	3953W	BOLT (2)	84 to * — FXRS, FXRT; 86 to * — FXR
	3	4014W	BOLT (2)	Late 84 & 85 — FXRS, FXRT
		4036	BOLT (2)	Early 84, 86 to * — FXR, FXRS, FXRT
	4	4319	BOLT (2)	84 to * — FXRS, FXRT; 86 to * — FXR
	5	5411	BOLT (4)	84 to * — FXRS, FXRT; 86 to * — FXR
	5A	5887	SPACER, bracket	84 to * — FXRS, FXRT; 86 to * — FXR
	6	6316HW	WASHER (4)	84 to * — FXRS, FXRT; 86 to * — FXR
	7	6701	WASHER (2)	84 to * — FXRS, FXRT; 86 to * — FXR
	8	6702	WASHER (2)	84 to * — FXRS; 86 to * — FXR
	9	7041	LOCKWASHER	84 to * — FXRS, FXRT; 86 to * — FXR
	10	7232	LOCKWASHER (2)	84 to * — FXRS, FXRT; 86 to * — FXR
	11	7531	LOCKNUT (4; 6 — 86)	84 to * — FXRS, FXRT; 86 to * — FXR
	12	7748W	NUT	84 to * — FXRS, FXRT; 86 to * — FXR
	13	7753	NUT (6; 4 — 86)	84 to * — FXRS, FXRT; 86 to * — FXR
	14	7780	NUT (2)	84 to * — FXRS, FXRT; 86 to * — FXR
	15	9955	CLAMP, shields (6)	84 to * — FXRS, FXRT; 86 to * — FXR
	16	10048	CLAMP, crossover shield (2)	84 to * — FXRS, FXRT; 86 to * — FXR
	17	65276—62	CLAMP, muffler (2)	84 to * — FXRS, FXRT; 86 to * — FXR
	18	65302—82	CLAMP, front exhaust pipe	84 to * — FXRS, FXRT; 86 to * — FXR
	19	65306—83	CLAMP, rear exhaust pipe	84 to * — FXRS, FXRT; 86 to * — FXR
	20	65310—83	BRACKET, rear exhaust	84 — FXRS, FXRT
		65310—85	BRACKET, rear exhaust	85 to * — FXRS, FXRT; 86 to * — FXR
	21	65324—83	GASKET, exhaust port (2)	84 to * — FXRS, FXRT; 86 to * — FXR
	22	65325—83	RETAINING RING, exhaust gasket (2)	84 to * — FXRS, FXRT; 86 to * — FXR
	23	65328—83	CLAMP, exhaust pipe to manifold (2)	84 to * — FXRS, FXRT; 86 to * — FXR
	24	65410—83	SHIELD, crossover (chrome)	84 to * — FXRS, FXRT; 86 to * — FXR
	25	65481—83A	SHIELD KIT, rear exhaust w/clamps (chrome)	84 & 85 — FXRS, FXRT
		65702—86	SHIELD, rear exhaust (chrome)	86 to * — FXR, FXRS, FXRT
	26	65482—83	SHIELD KIT, front exhaust w/clamps (chrome)	84 & 85 — FXRS, FXRT
		65732—86	SHIELD, front exhaust (chrome)	86 to * — FXR, FXRS, FXRT
	27	65571—86	SHIELD, front muffler (chrome)	84 to * — FXRS, FXRT; 86 to * — FXR
	28	65656—82A	MUFFLER, front (chrome)	84 to Early 86 — FXRT;
		65656—83	MUFFLER, front (chrome)	Late 84 to Early 86 — FXRS; Early 86 — FXR
		65738—84	MUFFLER, front (HDI part only)	Early 84 — FXRS
		65747—86	MUFFLER, front (chrome)	86 to * — FXR, FXRS, FXRT
	29	65657—82A	MUFFLER, rear (chrome)	Late 86 to * — FXR, FXRS, FXRT
		65657—83	MUFFLER, rear (chrome)	84 to * — FXRT; Late 84 to * — FXRS;
		65739—84	MUFFLER, rear (HDI part only)	86 to * — FXR
	30	65668—83	EXHAUST PIPE, rear (chrome)	Early 84 — FXRS
		65668—86	EXHAUST PIPE, rear (chrome)	86 to * — FXR, FXRS, FXRT
	31	65669—83	EXHAUST PIPE, front (chrome)	84 & 85 — FXRS, FXRT
		65669—86	EXHAUST PIPE, front (chrome)	86 to * — FXR, FXRS, FXRT
	32	65670—82B	BRACKET, front exhaust	84 to * — FXRS, FXRT; 86 to * — FXR
	33	65674—82	SUPPORT, muffler	84 to * — FXRS, FXRT; 86 to * — FXR
	34	65780—82	MOUNT, exhaust	84 to * — FXRS, FXRT; 86 to * — FXR
	35	65781—82	GASKET	84 to * — FXRS, FXRT; 86 to * — FXR
	36	65782—82	WASHER, exhaust	84 to * — FXRS, FXRT; 86 to * — FXR

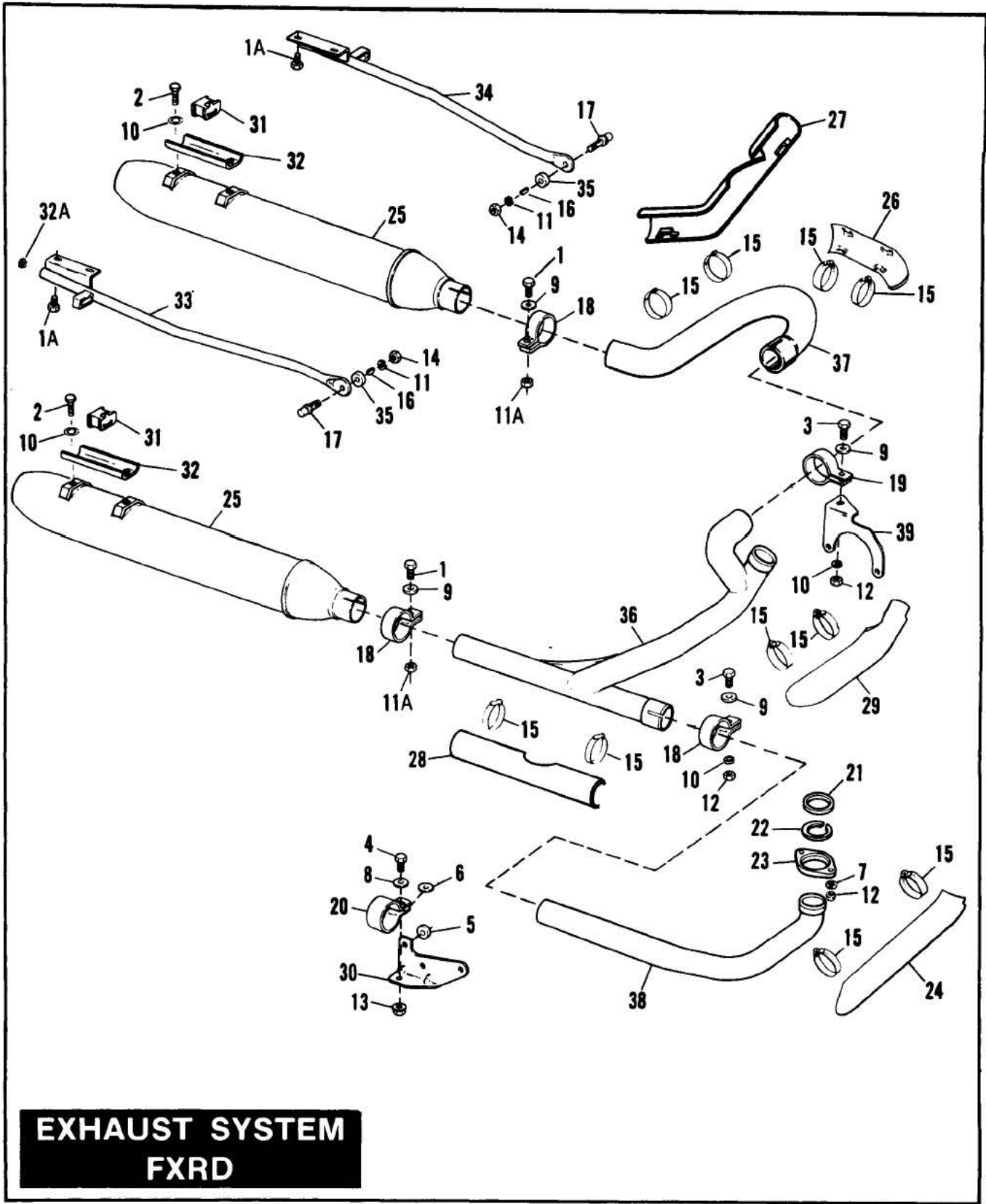

**EXHAUST SYSTEM  
FXRD**

RETAIL PRICE	INDEX NO.	PART NO.	NAME	USED ON
	1	2818	BOLT (2)	86 to * — FXRD
	1A	3445	BOLT (4)	86 to * — FXRD
	2	3953W	BOLT (4)	86 to * — FXRD
	3	4036	BOLT (2)	86 to * — FXRD
	4	4337W	BOLT	86 to * — FXRD
	5	5887	SPACER	86 to * — FXRD
	6	6019	WASHER	86 to * — FXRD
	7	6316HW	WASHER (4)	86 to * — FXRD
	8	6701	WASHER	86 to * — FXRD
	9	6702	WASHER (4)	86 to * — FXRD
	10	7041	LOCKWASHER (6)	86 to * — FXRD
	11	7068	LOCKWASHER (2)	86 to * — FXRD
	11A	7531	LOCKNUT (2)	86 to * — FXRD
	12	7753	NUT (6)	86 to * — FXRD
	13	7780	LOCKNUT	86 to * — FXRD
	14	7845	NUT (2)	86 to * — FXRD
	15	9955	CLAMP, shields (1)	86 to * — FXRD
	16	23985—18	KEY (2)	86 to * — FXRD
	17	50960—86	STUD, footboard mounting — right	Late 86 to * — FXRD
		50961—86	STUD, footboard mounting (2)	Early 86 — FXRD
		50962—86	STUD, footboard mounting — left	Late 86 to * — FXRD
	18	65276—62	CLAMP, muffler (3)	86 to * — FXRD
	19	65301—86	CLAMP, crossover	86 to * — FXRD
	20	65302—82	CLAMP, front exhaust pipe	86 to * — FXRD
	21	65324—83	GASKET, exhaust port (2)	86 to * — FXRD
	22	65325—83	RETAINING RING, exhaust gasket (2)	86 to * — FXRD
	23	65328—83	CLAMP, exhaust pipe to port (2)	86 to * — FXRD
	24	65342—86	SHIELD, front exhaust w/clamps (chrome)	86 to * — FXRD
	25	65354—86	MUFFLER (chrome)(2)	Early 86 — FXRD
		65359—86	MUFFLER (chrome)(2)	Late 86 to * — FXRD
		65369—86	MUFFLER (HDI part only)	N/A
	26	65431—86	SHIELD, crossover (chrome)	86 to * — FXRD
	27	65441—86	SHIELD, left exhaust (chrome)	86 to * — FXRD
	28	65594—86	SHIELD, right exhaust (chrome)	86 to * — FXRD
	29	65632—83A	SHIELD, rear exhaust (chrome)	86 to * — FXRD
	30	65670—82B	BRACKET, front exhaust	86 to * — FXRD
	31	65685—86	RUBBER MOUNT (2)	86 to * — FXRD
	32	65723—85	MOUNTING BRACKET (2)	86 to * — FXRD
	32A	65746—86	PLUG (2)	N/A
	33	65759—86	SUPPORT, muffler mounting, right	86 to * — FXRD
	34	65779—86	SUPPORT, muffler mounting, left	86 to * — FXRD
	35	65786—86	SPACER (2)	86 to * — FXRD
		65789—86	SHIELD, lower left exhaust w/clamps	86 to * — FXRD
	36	65794—86	EXHAUST PIPE, rear, right	86 to * — FXRD
	37	65798—86	EXHAUST PIPE, left	86 to * — FXRD
	38	65799—86	EXHAUST PIPE, front	86 to * — FXRD
	39	65801—86	BRACKET, rear exhaust	86 to * — FXRD

**INSTRUMENTS - FXRS,  
1984 & 1985 FXRT**

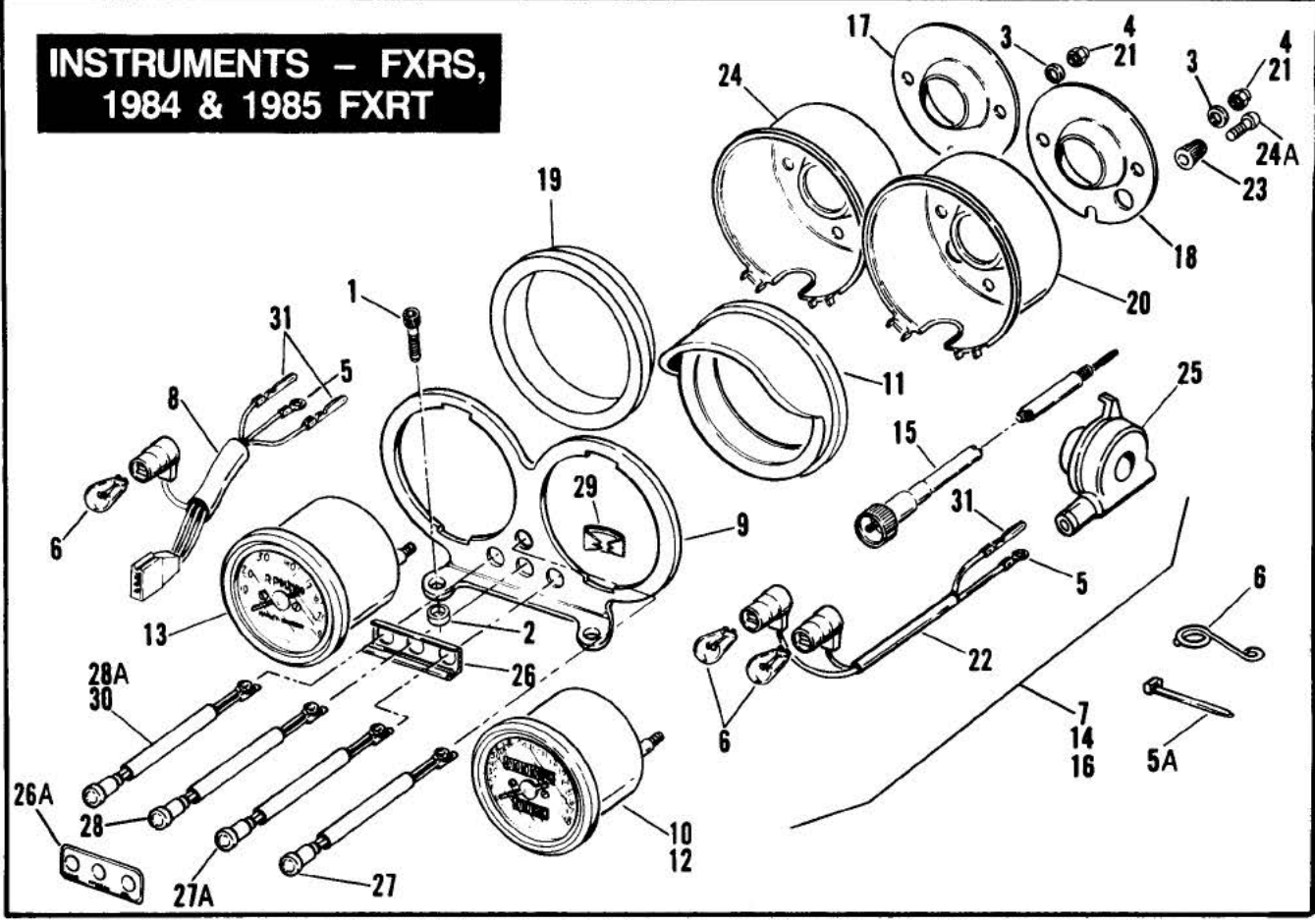

RETAIL PRICE	INDEX NO.	PART NO.	NAME	USED ON
	1	853	SCREW (2)	84 to * — FXRS; 84 & 85 — FXRT
	2	5736	SPACER (2)	84 to * — FXRS; 84 & 85 — FXRT
	3	6028	WASHER (black)(4)	84 & 85 — FXRT
	4	7545	ACORN NUT (black)(4)	84 & 85 — FXRT
	5	9857	WIRE TERMINAL, ring type, No. 10 hole, #16-22 wire(2)	84 to * — FXRS; 84 & 85 — FXRT
	5A	10081	CABLE STRAP	86 to * — FXRS
	6	45092—66A	GUIDE, cable	86 to * — FXRS
	6A	53439—79	BULB (2 - speedometer; 1 - tachometer)	84 to * — FXRS; 84 & 85 — FXRT
	7	67002—84	SPEEDOMETER & TACHOMETER, complete, w/bracket - m.p.h.	N/A 84 — FXRT
		67002—85	SPEEDOMETER & TACHOMETER, complete w/bracket - m.p.h.	N/A 85 — FXRT
	8	67034—83	BULB & SOCKET, with terminals — tachometer	84 to * — FXRS; 84 & 85 — FXRT
	9	67036—83	MOUNTING BRACKET, speedometer & tachometer (black)	84 & 85 — FXRS, FXRT
		67036—86	MOUNTING BRACKET, speedometer & tachometer	86 to * — FXRS
	10	67037—83	SPEEDOMETER, complete with wiring — m.p.h.	84 — FXRS, FXRT
		67037—85A	SPEEDOMETER, complete with wiring — m.p.h.	85 to * — FXRS; 85 — FXRT
	11	67039—83	RUBBER MOUNT WITH VISOR (black)(2)	84 & 85 — FXRT
	12	67041—83A	SPEEDOMETER, complete, w/wiring k.p.h.	84 to * — FXRS; 84 & 85 — FXRT
	13	67042—83	TACHOMETER, complete, w/wiring (k.p.h. kit — 85 & later)	84 to * — FXRS; 84 & 85 — FXRT
		67042—85	TACHOMETER, part of 1985 m.p.h. kit	85 to * — FXRS; 85 — FXRT
	14	67046—83	SPEEDOMETER & TACHOMETER, complete, w/bracket - m.p.h.	N/A 84 — FXRS
		67046—85	SPEEDOMETER & TACHOMETER, complete, w/bracket - m.p.h.	85 — FXRS
		67046—86	SPEEDOMETER & TACHOMETER, complete, w/bracket - m.p.h.	86 to * — FXRS
		67047—83	SPEEDOMETER & TACHOMETER, complete, w/bracket - k.p.h.	N/A 84 — FXRS
		67047—86A	SPEEDOMETER & TACHOMETER, complete, w/bracket - k.p.h. (HDI part only)	86 to * — FXRS
	15	67048—83A	CABLE ASSEMBLY, speedometer drive	85 — FXRT
		67052—78B	CABLE ASSEMBLY, speedometer drive	84 to * — FXRS
		67054—83B	CABLE ASSEMBLY, speedometer drive	84 — FXRT
	16	67056—84	SPEEDOMETER & TACHOMETER, complete, w/bracket - k.p.h.	N/A 84 & 85 — FXRT
	17	67085—83	TRIM, tachometer (chrome)	84 to * — FXRS
	18	67103—83	TRIM, speedometer (chrome)	84 to * — FXRS
	19	67104—83	GASKET, speedometer & tachometer mounting (2)	84 to * — FXRS
	20	67105—83	COVER, speedometer — lower (black)	84 to * — FXRS; 84 & 85 — FXRT
	21	67106—83	ACORN NUT (chrome)(4)	84 to * — FXRS
	22	67107—83	BULB & SOCKET, with terminals — speedometer	84 to * — FXRS; 84 & 85 — FXRT
	23	67108—83	RESET KNOB, odometer (chrome)	84 to * — FXRS; 84 & 85 — FXRT
	24	67112—83	COVER, tachometer — lower (black)	84 to * — FXRS; 84 & 85 — FXRT
	24A	67117—85	SCREW, reset knob	84 to * — FXRS; 84 & 85 — FXRT
	25	67127—84A	DRIVE UNIT, speedometer	84 to * — FXRS; 84 & 85 — FXRT
	26	68461—83	SUPPORT BRACKET, indicator lamps	84 & 85 — FXRS, FXRT
	26A	68464—86	TRIM, warning lights (black)	86 to * — FXRS
	27	68468—86	INDICATOR LAMP, turn signals (amber)	86 to * — FXRS
	27A	68489—83	INDICATOR LAMP, oil pressure (red)	84 & 85 — FXRS, FXRT
		68489—86	INDICATOR LAMP, oil pressure (red)	86 to * — FXRS
	28	68574—83	INDICATOR LAMP, transmission neutral (green)	84 & 85 — FXRS, FXRT
		68574—86	INDICATOR LAMP, neutral (green)	86 to * — FXRS
	28A	68597—86	INDICATOR LAMP, high beam (blue)	86 to * — FXRS
	29	68608—83	SPEED NUT (3; 4 — 86 & later)	84 to * — FXRS; 84 & 85 — FXRT
	30	70021—83	INDICATOR LAMP, high beam (blue)	84 & 85 — FXRS, FXRT
	31	72038—71	TERMINAL, single pin (3; 7 — FXR)	84 to * — FXRS; 84 & 85 — FXRT

# INSTRUMENTS - FXR

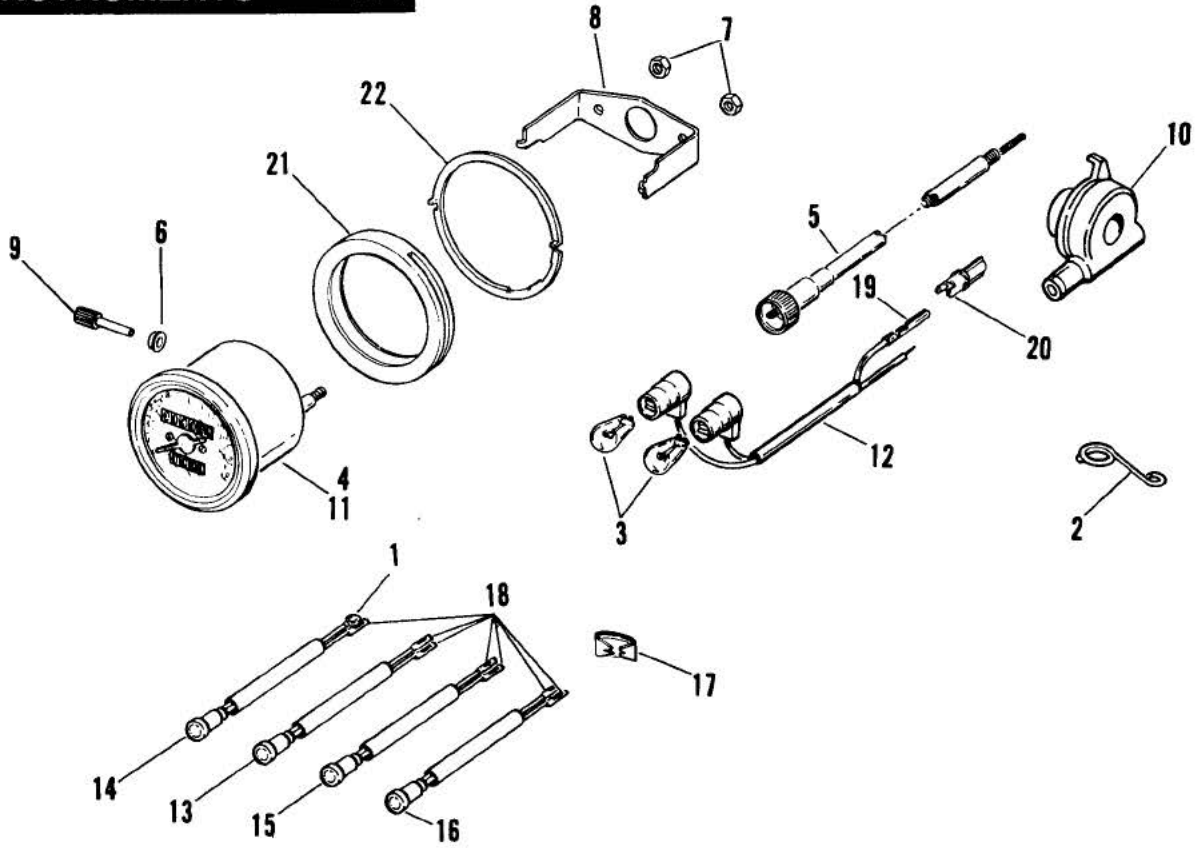

RETAIL PRICE	INDEX NO.	PART NO.	NAME	USED ON
	1	9857	WIRE TERMINAL, ring type, No. 10 hole #16-22 wire ..	86 to * — FXR
	2	45092—66A	GUIDE, cable .....	86 to * — FXR
	3	53439—79	BULB (2) .....	86 to * — FXR
	4	67020—85	SPEEDOMETER - m.p.h. ....	86 to * — FXR
		67021—85A	SPEEDOMETER - k.p.h. ....	86 to * — FXR
	5	67078—85A	CABLE ASSEMBLY, speedometer drive .....	86 to * — FXR
	6	67086—85	GROMMET .....	86 to * — FXR
	7	67094—85	NUT (2) .....	86 to * — FXR
	8	67095—85	BRACKET, mounting .....	86 to * — FXR
	9	67122—85	RESET KNOB, odometer (chrome) .....	86 to * — FXR
	10	67127—84A	DRIVE UNIT, speedometer .....	86 to * — FXR
	11	67200—86	SPEEDOMETER, complete w/wiring - m.p.h. ....	86 to * — FXR
		67201—86	SPEEDOMETER, complete w/wiring - k.p.h. ....	86 to * — FXR
	12	67202—86	BULB & SOCKET, with terminals .....	86 to * — FXR
	13	67851—86	INDICATOR LAMP, neutral (green) .....	86 to * — FXR
	14	67862—86	INDICATOR LAMP, high beam (blue) .....	86 to * — FXR
	15	67864—86	INDICATOR LAMP, turn signals (amber) .....	86 to * — FXR
	16	68536—86	INDICATOR LAMP, oil pressure (red) .....	86 to * — FXR
	17	68608—83	SPEED NUT (4) .....	86 to * — FXR
	18	72038—71	TERMINAL, single pin (7) .....	86 to * — FXR
	19	72039—71	PIN, single socket .....	86 to * — FXR
	20	72043—71	CONNECTOR, single pin .....	86 to * — FXR
	21	92061—83	CUSHION (rubber) .....	86 to * — FXR
	22	92070—86	PLATE, mounting .....	86 to * — FXR

**INSTRUMENTS  
AND GAUGES —  
1986 FXRT, FXRD**

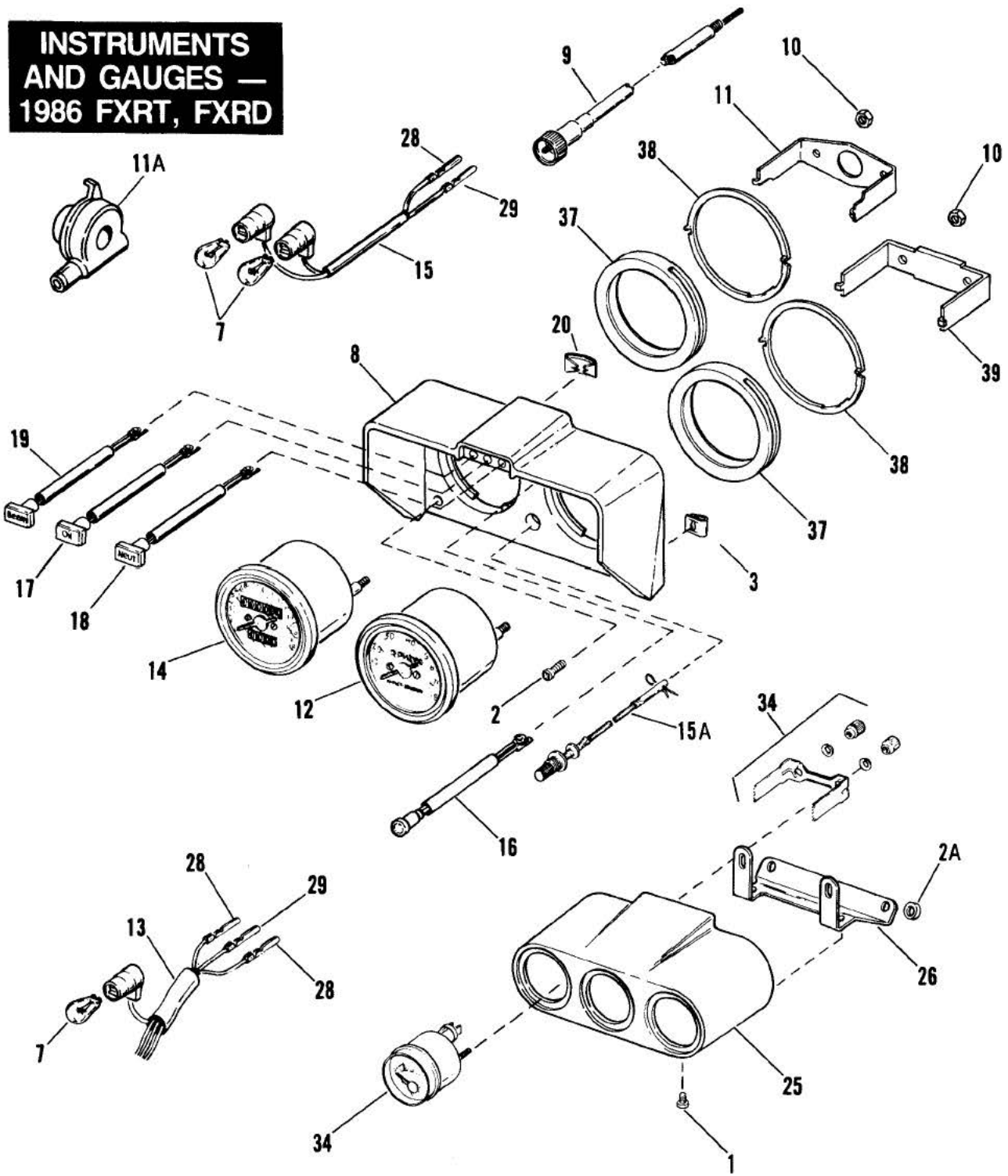



RETAIL PRICE	INDEX NO.	PART NO.	NAME	USED ON
	1	2731W	SCREW (2)	86 to * — FXRD
	2	3766	SCREW (4)	86 to * — FXRD, FXRT
	2A	5743	SPACER (2)	86 to * — FXRD
	3	8107	SPEEDNUT (4)	86 to * — FXRD, FXRT
	7	53439—79	BULB (2 — speedometer; 1 — tachometer)	86 to * — FXRT, FXRD
	8	67029—86	VISOR, instrument	86 to * — FXRT, FXRD
	9	67054—83B	CABLE, speedometer	86 to * — FXRT, FXRD
	10	67094—85	NUT (4)	86 to * — FXRT, FXRD
	11	67097—86	BRACKET, speedometer mounting	86 to * — FXRT, FXRD
	11A	67127—84A	DRIVE UNIT, speedometer	86 to * — FXRT, FXRD
	12	67152—86	TACHOMETER (m.p.h. kit)	86 to * — FXRT, FXRD
		67158—86	TACHOMETER (k.p.h. kit) (HDI part only)	86 to * — FXRT, FXRD
	13	67153—86	SOCKET AND BULB, tachometer	86 to * — FXRT, FXRD
	14	67154—86	SPEEDOMETER (m.p.h.)	86 to * — FXRT, FXRD
		67157—86	SPEEDOMETER (k.p.h.)	86 to * — FXRT, FXRD
	15	67155—86	SOCKET AND BULBS, speedometer	86 to * — FXRT, FXRD
	15A	67156—86	CABLE, odometer reset	86 to * — FXRT, FXRD
	16	68465—86	INDICATOR LAMP, turn signal (amber)(2)	86 to * — FXRT, FXRD
	17	68489—83	INDICATOR LAMP, oil pressure (red)	86 to * — FXRT, FXRD
	18	68574—83	INDICATOR LAMP, neutral (green)	86 to * — FXRT, FXRD
	19	68588—86	INDICATOR LAMP, high beam (blue)	86 to * — FXRT, FXRD
	20	68608—83	SPEEDNUT (5)	86 to * — FXRT, FXRD
		69548—86	HARNESS, gauge pod (not illus.)	86 to * — FXRD
	25	71251—86	POD, gauge	86 to * — FXRD
	26	71252—86	BRACKET, gauge mounting	86 to * — FXRD
	28	72038—71	SOCKET, single pin (7)	86 to * — FXRT, FXRD
	29	72039—71	PIN, single socket (9)	86 to * — FXRT, FXRD
	34	74526—86	VOLTMETER	86 to * — FXRD
		75013—86	CLOCK, quartz	86 to * — FXRD
		75032—86	OIL PRESSURE GAUGE	86 to * — FXRD
	37	92061—83	CUSHION (rubber)(2)	86 to * — FXRT, FXRD
	38	92068—83	PLATE, mounting (2)	86 to * — FXRT, FXRD
	39	92077—83	BRACKET, tachometer mounting	86 to * — FXRT, FXRD

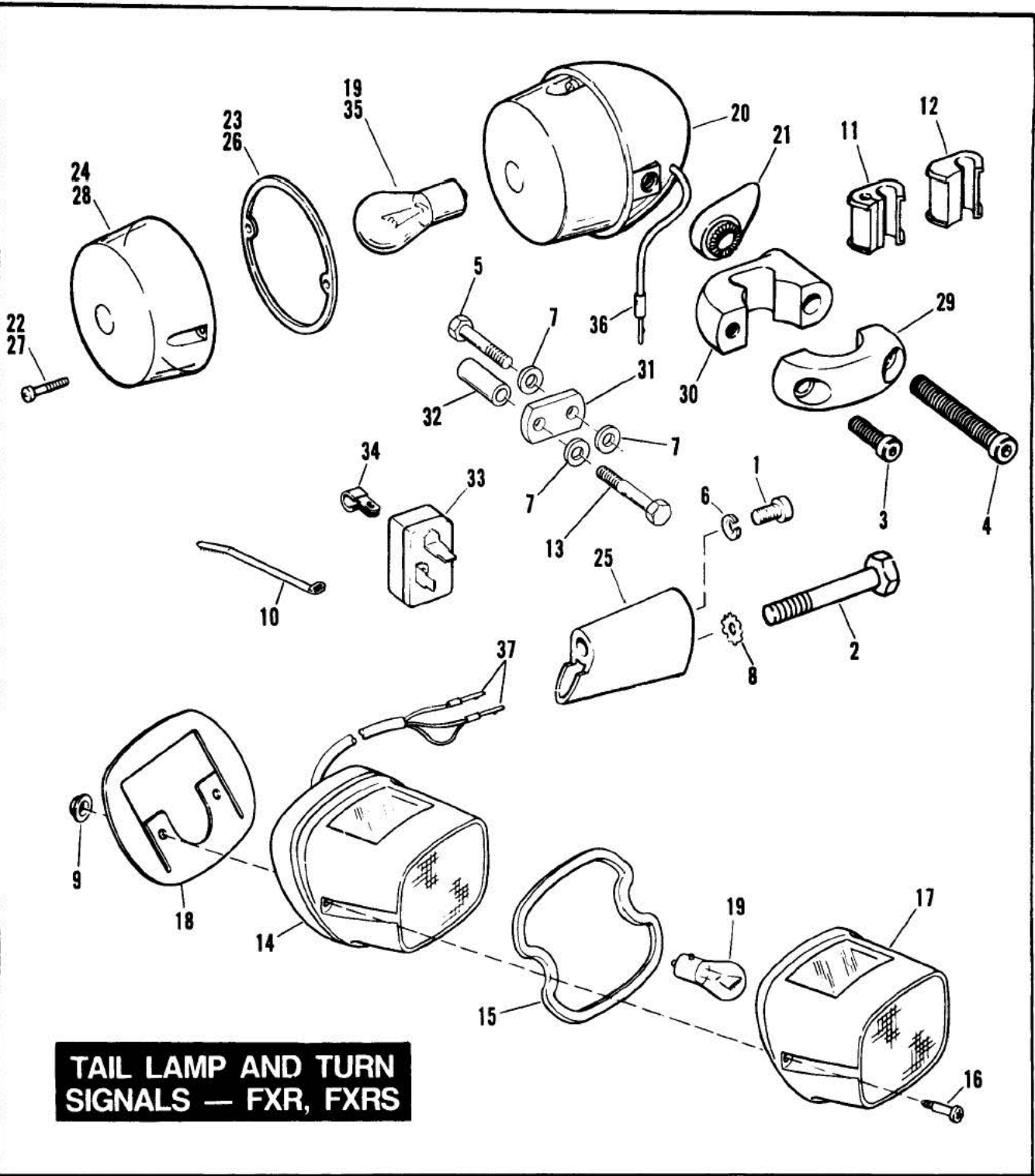

# TAIL LAMP AND TURN SIGNALS — FXR, FXRS

RS40

RETAIL PRICE	INDEX NO.	PART NO.	NAME	USED ON
	1	2698	SCREW (2)	84 to * — FXRS; 86 to * — FXR
	2	4412	BOLT (2)	84 to * — FXRS; 86 to * — FXR
	3	4069	SCREW (2)	84 to * — FXRS
	4	4070	SCREW (2)	84 to * — FXRS
	5	4391	BOLT (4)	86 to * — FXR
	6	7042	LOCKWASHER (2)	84 to * — FXRS; 86 to * — FXR
	7	7127	LOCKWASHER (6)	86 to * — FXR
	8	7130W	LOCKWASHER (2)	84 to * — FXRS; 86 to * — FXR
	9	7501	NUT (2)	84 to * — FXRS
	10	10006	CABLE STRAP	84 to * — FXRS; 86 to * — FXR
		10065	CABLE STRAP	86 to * — FXR
	11	11449	GROMMET (2)	84 to * — FXRS
	12	11442	GROMMET, front left clamp	84 & 85 — FXRS
	13	30013—71	BOLT (2)	86 to * — FXR
		59256—84	REFLECTOR, round (HDI part only)	86 to * — FXR, FXRS
	14	68008—73A	TAIL LAMP ASSEMBLY	84 to * — FXRS; 86 to * — FXR
	15	68025—73	GASKET, tail lamp lens	84 to * — FXRS; 86 to * — FXR
	16	68026—73	SCREW (2)	84 to * — FXRS; 86 to * — FXR
	17	68034—77	LENS, tail lamp	84 to * — FXRS; 86 to * — FXR
	18	68123—73	GASKET, tail lamp housing	84 to * — FXRS; 86 to * — FXR
	19	68165—64	BULB, tail lamp & turn signal (3 — 86 & Later)	84 to * — FXRS; 86 to * — FXR
	20	68404—86	LAMP WITH WIRE, front (2)	86 to * — FXR
		68406—86B	LAMP WITH WIRE, front (2)	86 to * — FXRS
		68407—86	LAMP WITH WIRE, rear (2)	86 to * — FXR, FXRS
		68435—84	LAMP WITH WIRE, front and rear (amber)(4)	84 & 85 — FXRS
	21	68477—73	BRACKET, clamp to lamp (2)	84 to * — FXRS; 86 to * — FXR
	22	68452—86	SCREW (8)	86 to * — FXR, FXRS
	23	68455—86	O-RING (4)	86 to * — FXR, FXRS
	24	68457—86	LENS, turn signal (4)	86 to * — FXR, FXRS
	25	68480—73	ARM, rear indicator light (2)	84 to * — FXRS; 86 to * — FXR
	26	68481—73	GASKET, turn signal lens (4)	84 & 85 — FXRS
	27	68482—73	SCREW, turn signal lens (8)	84 & 85 — FXRS
	28	68483—73	LENS, turn signal (amber)(4)	84 & 85 — FXRS
	29	68486—82A	CLAMP, upper, front indicator lamp (2)	84 to * — FXRS
	30	68487—82	CLAMP, lower, front indicator lamp (2)	84 to * — FXRS
	31	68504—83	BRACKET, directional mounting (2)	86 to * — FXR
	32	68531—78	SPACER, directional mounting (2)	86 to * — FXR
	33	68543—64B	FLASHER, directional signal	84 to * — FXRS; 86 to * — FXR
		68549—84	SPACER, rear turn signal (HDI part only)	86 to * — FXR, FXRS
		68550—83	FLASHER, turn signal (HDI part only)	86 to * — FXR, FXRS
	34	68562—84	CLIP	84 & 85 — FXRS
	35	68572—64A	BULB, turn signal (4; 2 — 86 & Later)	84 to * — FXRS; 86 to * — FXR
	36	72038—71	SOCKET, single pin (2; 4 — 86 & Later)	84 to * — FXRS; 86 to * — FXR
	37	72039—71	PIN, single socket (2; 4 — 86 & Later)	84 to * — FXRS; 86 to * — FXR

**TAIL LAMP AND REAR  
TURN SIGNALS - FXRT, FXRD**

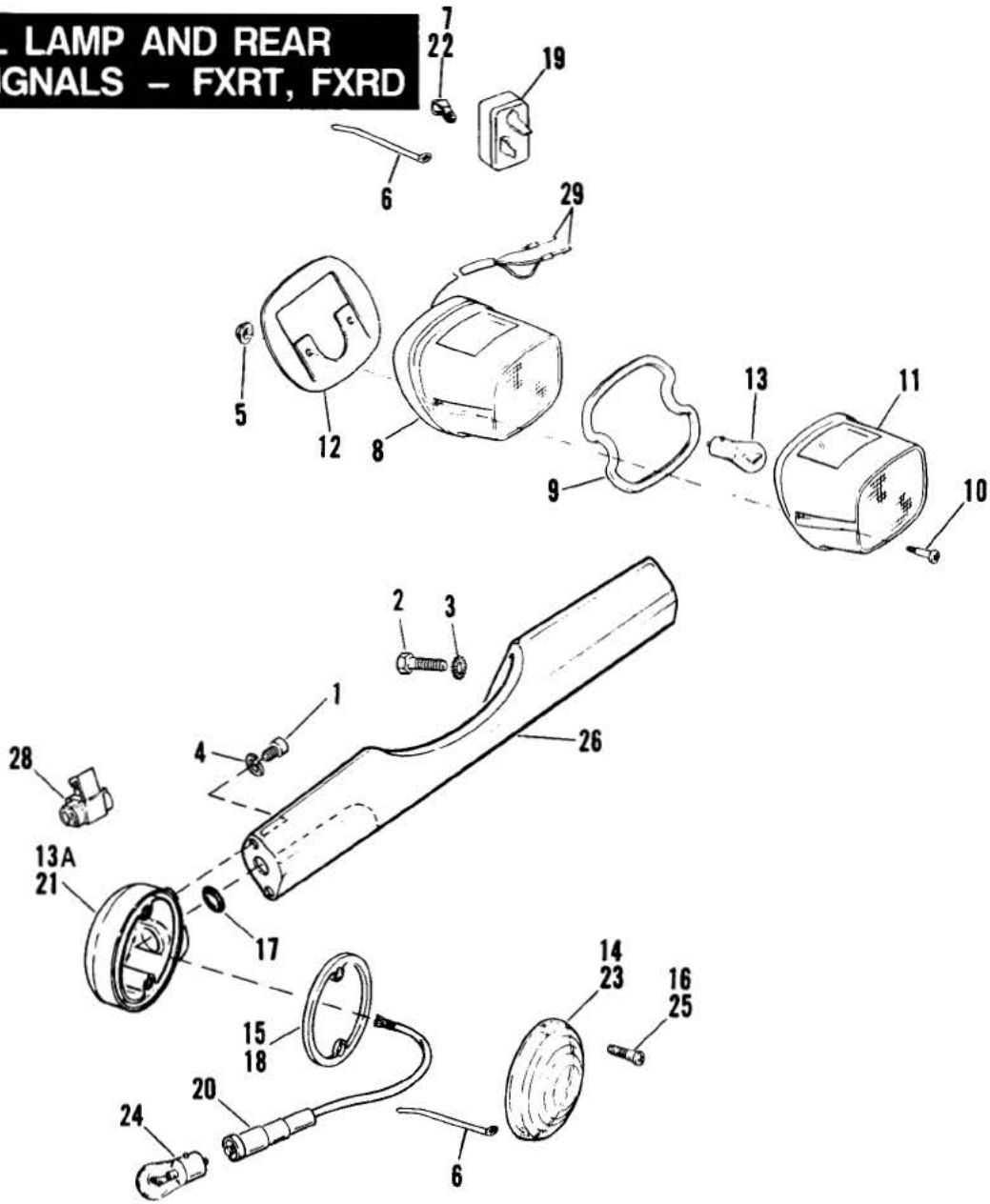

**TAIL LAMP AND REAR TURN SIGNALS — FXRT, FXRD**

**RS40A**

RETAIL PRICE	INDEX NO.	PART NO.	NAME	USED ON
	1	2692W	SCREW (4)	84 to * — FXRT; 86 to * — FXRD
	2	3767B	BOLT (2)	84 to * — FXRT; 86 to * — FXRD
	3	7036	LOCKWASHER (2)	84 & 85 — FXRT
		7230	LOCKWASHER (2)	86 to * — FXRT, FXRD
	4	7069	LOCKWASHER (4)	84 to * — FXRT; 86 to * — FXRD
	5	7501	NUT (2)	84 to * — FXRT; 86 to * — FXRD
	6	10006	CABLE STRAP (2)	84 & 85 — FXRT
		10065	CABLE STRAP (2)	86 to * — FXRT, FXRD
	7	10033	CLIP	86 to * — FXRT, FXRD
		59270—84	REFLECTOR, round (HDI part only)	86 to * — FXRT, FXRD
	8	68008—73A	TAIL LAMP ASSEMBLY	84 to * — FXRT; 86 to * — FXRD
	9	68025—73	GASKET, tail lamp lens	84 to * — FXRT; 86 to * — FXRD
	10	68026—73	SCREW (2)	84 to * — FXRT; 86 to * — FXRD
	11	68034—77	LENS, tail lamp	84 to * — FXRT; 86 to * — FXRD
	12	68123—73	GASKET, tail lamp housing	84 to * — FXRT; 86 to * — FXRD
	13	68165—64	BULB, tail lamp	84 to * — FXRT; 86 to * — FXRD
	13A	68402—86	LAMP WITH WIRE (amber)(2)	86 to * — FXRT, FXRD
	14	68440—86	LENS (amber)(2)	86 to * — FXRT, FXRD
	15	68451—86	O-RING (2)	86 to * — FXRT, FXRD
	16	68452—86	SCREW w/O-ring (4)	86 to * — FXRT, FXRD
	17	68520—63	O-RING, lamp mounting (2)	84 & 85 — FXRT
	18	68521—63A	GASKET, lens	84 & 85 — FXRT
	19	68543—64B	FLASHER, directional signal	84 to * — FXRT; 86 to * — FXRD
		68550—83	FLASHER, turn signals (HDI part only)	86 to * — FXRT, FXRD
	20	68554—82	WIRE	84 & 85 — FXRT
	21	68557—70A	LAMP WITH WIRE (amber)(2)	84 & 85 — FXRT
	22	68562—84	CLIP	84 & 85 — FXRT
	23	68571—63A	LENS (amber)(2)	84 & 85 — FXRT
	24	68572—64A	BULB (2)	84 to * — FXRT; 86 to * — FXRD
	25	68586—63A	SCREW, lens (4)	84 & 85 — FXRT
	26	68643—83B	BRACKET, rear turn signal lamps	84 to * — FXRT
	28	70576—68	WIRE CONNECTOR (2)	84 & 85 — FXRT
	29	72039—71	PIN, single socket (4)	84 to * — FXRT; 86 to * — FXRD
		72041—71	CONNECTOR, six pin	84 to * — FXRT; 86 to * — FXRD

# HORN AND MIRROR

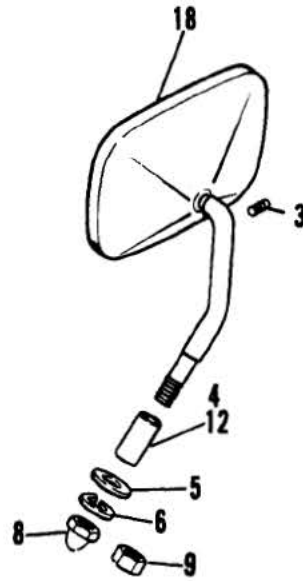
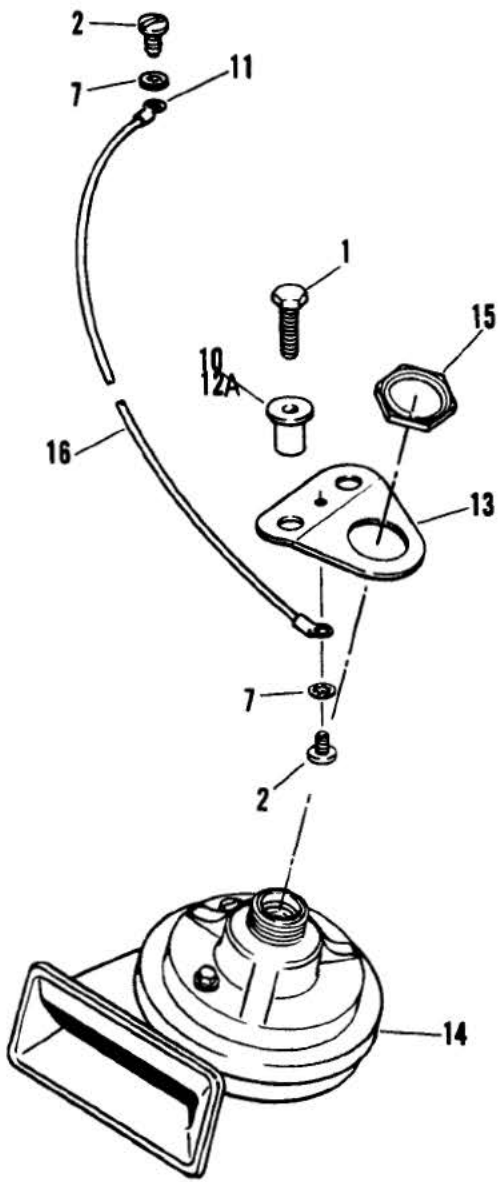

RETAIL PRICE	INDEX NO.	PART NO.	NAME	USED ON
	1	2339	BOLT (2) .....	84 — FXRS, FXRT; 86 to * — All Models
		2592	SCREW (2) .....	85 — FXRS, FXRT
	2	2731W	SCREW (2) .....	84 to * — All Models
	3	3233	SET SCREW .....	84 & 85 — FXRS, FXRT
	4	5714	SPACER (2) .....	84 to * — All Models
	5	6702	WASHER (2) .....	84 to * — All Models
	6	7041	LOCKWASHER (2) .....	84 to * — All Models
	7	7118	LOCKWASHER (2) .....	84 to * — All Models
	8	7736	ACORN NUT (2) .....	84 to * — All Models
	9	7744	JAMNUT .....	84 & 85 — FXRS, FXRT
	10	8098	WELL NUT (2) .....	84 — FXRS, FXRT; 86 to * — All Models
	11	9857	WIRE TERMINAL, ring type - no. 10 hole (2) .....	84 to * — All Models
	12	47311-77	SPACER .....	84 & 85 — FXRS, FXRT
	12A	59271-68	WELL NUT (2) .....	85 — FXRS, FXRT
	13	69006-82	BRACKET .....	Early 84 — FXRS, FXRT
		69006-84	BRACKET, horn mounting .....	Late 84 to * — All Models
	14	69007-82C	HORN, high note .....	Early 84 — FXRS, FXRT
		69007-84	HORN .....	Late 84 to * — All Models
	15	69149-65	NUT, horn to mounting bracket .....	Early 84 — FXRS, FXRT
	16	69606-82	WIRE ASSEMBLY, horn ground .....	84 to * — All Models
	18	91875-82	MIRROR KIT — short (right) .....	84 to * — All Models
		91892-82	MIRROR KIT — short (left) .....	84 to * — All Models

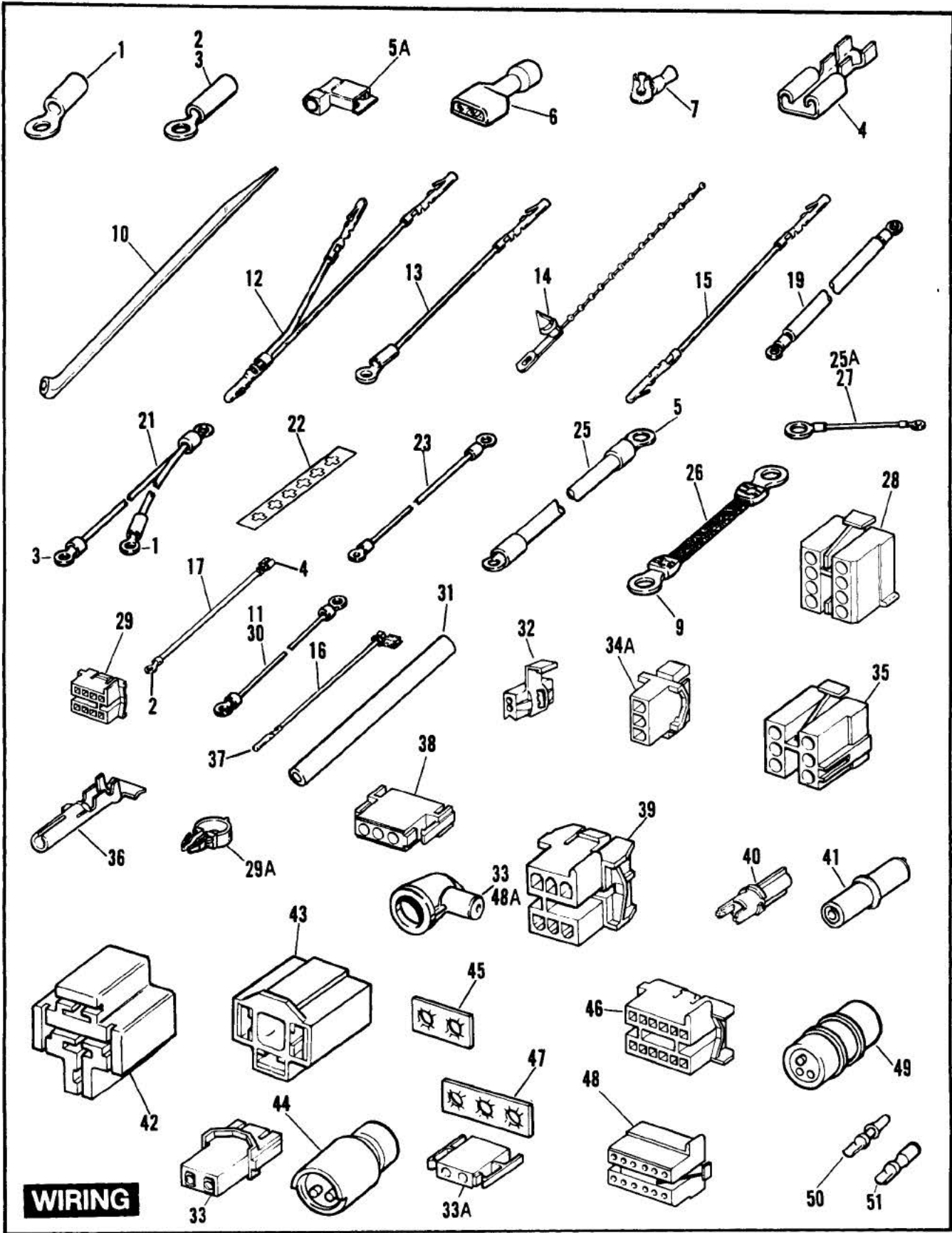



RETAIL PRICE	INDEX NO.	PART NO.	NAME	USED ON
	1	9857	WIRE TERMINAL, ring type, no. 10 hole, #16-22 wire	84 to * — All Models
	2	9858	WIRE TERMINAL, ring type, 1/4 dia. hole, #16-22 wire	84 to * — FXRS; 86 to * — FXR
	3	9862	WIRE TERMINAL, ring type, no. 10 hole, #14-16 wire	84 to * — All Models
		9863	WIRE TERMINAL, ring type 1/4 dia. hole, #14-16 wire	86 to * — FXR, FXRS
		9866	WIRE TERMINAL, ring type, no. 10 hole, #10-12 wire	85 to * — All Models
	4	9875	WIRE TERMINAL, female spade, 5/16 slot, #16-22 wire	84 to * — FXRS; 86 to * — FXR
	5	9879	WIRE TERMINAL, ring, 1/4 dia., #10-12 wire-u-clamp	N/A 84 to * — All Models
	5A	9898	WIRE TERMINAL, female spade type, #14-16 wire	86 to * — All Models
	6	9900	WIRE TERMINAL, female spade, 3/16 slot #18-22 wire	84 to * — All Models
	7	9905	WIRE TERMINAL, 1/4 dia. cap type, #18-22 wire	84 to * — All Models
	8	9937	WIRE TERMINAL, female spade, 1/4 slot, #14-16 wire	84 to * — All Models
	10	10006	CABLE STRAP (black)	84 to * — All Models
		10039	CABLE STRAP	86 to * — FXRS
		10065	CABLE STRAP (9)	85 to * — All Models
		69545—82A	MAIN WIRING HARNESS	Early 84 — FXRS, FXRT
		69545—84	MAIN WIRING HARNESS	Late 84 & Early 85 — FXRS, FXRT
		69545—86	MAIN WIRING HARNESS	86 to * — FXRD
		69551—85	MAIN WIRING HARNESS	Late 85 — FXRS, FXRT; 86 to * — FXR, FXRS
		69554—86	MAIN WIRING HARNESS	86 to * — FXRT
		69548—86	WIRING HARNESS, gauge pod	86 to * — FXRD
	11	69620—86	WIRE, light to accy. circuit breakers	86 to * — FXRT, FXRD
	12	70003—83	CONNECTING WIRE, accy. to inst. conn. (orange)	N/A 84 to * — FXRS, FXRT; 86 to * — FXR
	13	70004—83	CONNECTING WIRE, unswitched acc. to fairing conn. (black)	N/A 84 to * — FXRT
	14	70005—70	CABLE STRAP	84 to * — All Models
	15	70007—83	WIRE, lights & hi-beam indicator to inst. conn. (white)	N/A 84 & 85 — FXRT
		70012—83	CONNECTING WIRE, left directional to fairing conn. (violet)	N/A 84 & 85 — FXRT
		70013—83	CONNECTING WIRE, accy. to fairing conn. (orange)	84 & 85 — FXRT
		70014—83	CONNECTING WIRE, right directional to fairing conn. (brown)	N/A 84 & 85 — FXRT
		70019—86	WIRE ASSEMBLY, indicator lamp (blue)	86 to * — FXR, FXRT
		70022—83	WIRE ASSEMBLY, to left front directional	85 to * — FXRS; 86 to * — FXR
		70027—83	WIRE ASSEMBLY, to right front directional	85 to * — FXRS; 86 to * — FXR
	16	70049—83	WIRE ASSEMBLY, flasher connection - headlamp housing	85 to * — FXRS; 86 to * — FXR
	17	70050—83	WIRE ASSEMBLY, headlamp ground (black)	85 to * — FXRS; 86 to * — FXR
	19	70034—82	WIRE, battery positive to circuit breaker (red)	84 to * — All Models
		70035—82	WIRE, ignition to light circuit breaker (green)	N/A Early 84 — FXRS, FXRT
	21	70036—82	WIRE, ignition to ign. circuit breaker (white)	N/A Early 84 — FXRS, FXRT
	22	70043—81	LABEL, positive	84 to * — All Models
	23	70062—85	CABLE, battery negative	Late 85 to * — All Models
		70069—65B	CABLE, battery positive to solenoid	84 to * — All Models
		70083—82	WIRE ASSEMBLY, battery positive to starter relay	Late 84 & Early 85 — FXRT
		70097—75	CABLE, battery negative	84 & 85 — FXRS
	25	70100—79A	CABLE, solenoid to starter	84 to * — All Models
	25A	70146—84	WIRE ASSEMBLY, starter solenoid positive terminal to pull-in terminal	Late 84 & Early 85 — FXRS, FXRT
		70155—84	WIRE ASSEMBLY, starter relay ground	N/A Late 84 & Early 85 — FXRS, FXRT
		70156—84	WIRE ASSEMBLY, starter relay positive to solenoid terminal	Late 84 & Early 85 — FXRS, FXRT
		70246—85	WIRE ASSEMBLY, starter relay positive to solenoid terminal	Late 85 — FXRS, FXRT
	26	70186—82	GROUND STRAP	84 to * — All Models
	27	70191—73A	CABLE ASSEMBLY, handlebar ground	84 to * — All Models
	28	70287—81	HOUSING, eight socket	84 to * — FXRT; 86 to * — FXRD
	29	70288—81	HOUSING, eight pin	84 to * — FXRT; 86 to * — FXRD
	29A	70345—84	RETAINER, wiring harness	85 to * — All Models
	30	70422—82	WIRE, ignition to main circuit breaker (red)	N/A Early 84 — FXRS, FXRT

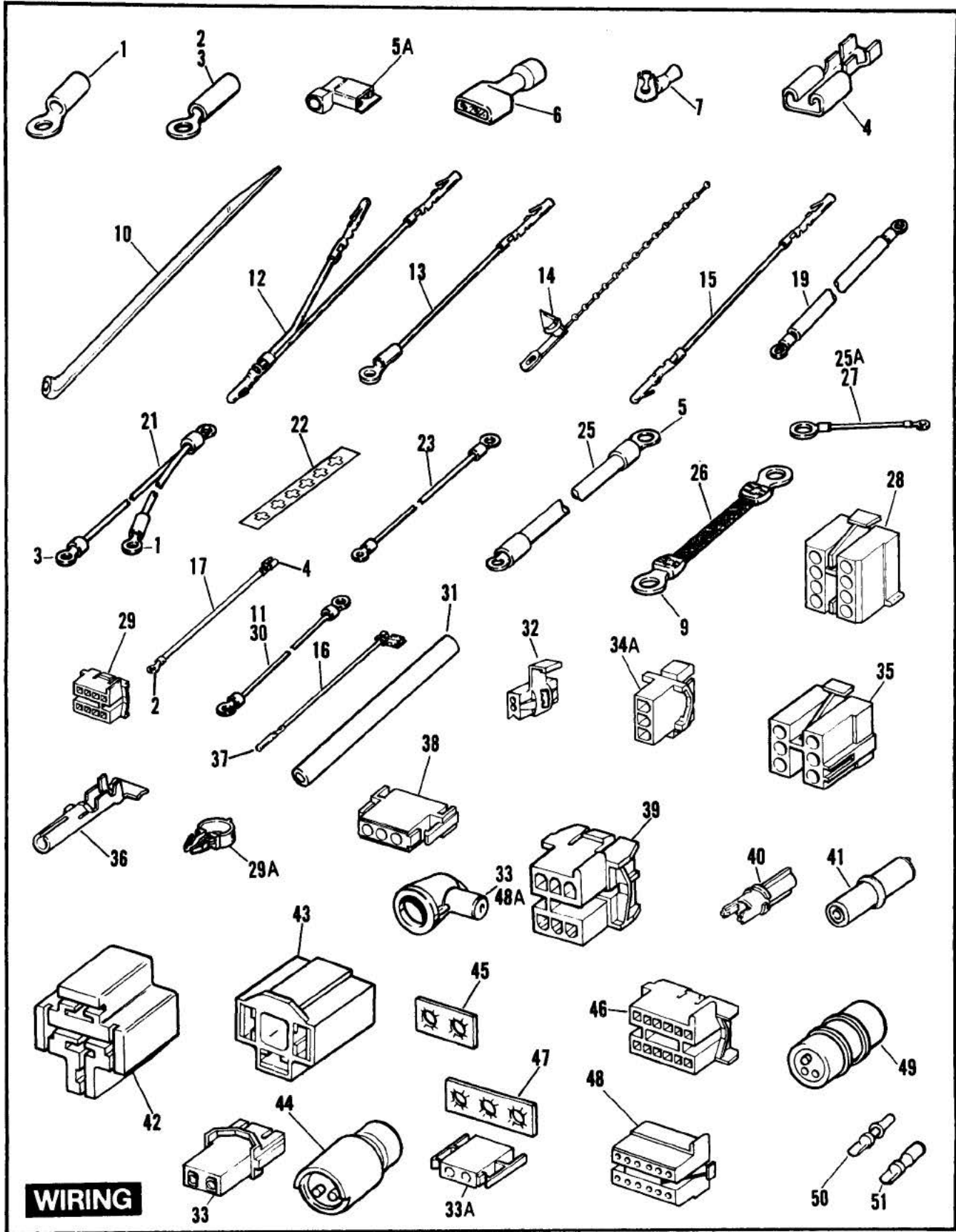

RETAIL PRICE	INDEX NO.	PART NO.	NAME	USED ON
	31	70551-69	CONDUIT, 1/8 I.D. x 10 ft. long (black vinyl)(hi-temp)	84 to * — All Models
		70552-69	CONDUIT, 3/8 I.D. x 10 ft. long (black vinyl)	84 to * — All Models
		70553-69	CONDUIT, 7/16 I.D. x 10 ft. long (black vinyl)	84 to * — All Models
		70554-69	CONDUIT, 1/4 I.D. x 10 ft. long (black vinyl)	84 to * — All Models
		70555-69	CONDUIT, 1/4 I.D. x 10 ft. long (black vinyl)(hi-temp)	84 to * — All Models
		70556-71	CONDUIT, 5/16 I.D. x 10 ft. long (black vinyl)	84 to * — All Models
		70558-71	CONDUIT, 1/2 I.D. x 10 ft. long (black vinyl)	84 to * — All Models
		70559-71	CONDUIT, 1/8 I.D. x 10 ft. long (black vinyl)	84 to * — All Models
	32	70576-68	WIRE CONNECTOR	84 — FXRS, FXRT; 86 to * — FXR
	33	70579-65	BOOT, insulating	85 to * — FXRS, FXRT; 86 to * — FXR
	33A	72034-71	HOUSING, two pin	86 to * — FXR, FXRS
	34	72035-71	HOUSING, two socket	86 to * — FXR, FXRS
	34A	72036-71	CONNECTOR, three terminal	84 & 85 — FXRT
	35	72037-71	CONNECTOR, six socket terminals	84 to * — All Models
	36	72038-71	SOCKET, single pin terminal	84 to * — All Models
	37	72039-71	PIN, single socket terminal	84 to * — All Models
	38	72040-71	HOUSING, three socket	84 & 85 — FXRT
	39	72041-71	CONNECTOR, six pin terminal	84 to * — All Models
	40	72043-71	CONNECTOR, single pin	84 to * — All Models
	41	72044-71	CONNECTOR, single socket	84 to * — All Models
	42	72046-79	INSULATOR, spade terminals	84 to * — All Models
	43	72047-71	INSULATOR, spade terminals	84 to * — All Models
	44	72051-77	RECEPTACLE, ignition module	84 to * — All Models
	45	72275-74	CONNECTOR TAB, two terminal	84 to * — All Models
	46	72276-74	HOUSING, single pin terminal	84 to * — All Models
	47	72277-74	CONNECTOR TAB, three terminal	84 to * — All Models
	48	72278-74	CONNECTOR, twelve socket	84 to * — All Models
	48A	74407-86	BOOT, insulating	86 to * — FXRD
	49	74521-77	CONNECTOR, pin and socket	84 to * — All Models
	50	74536-77A	PIN, ignition module & sensor assembly	84 to * — All Models
	51	74539-77A	SOCKET, ignition module & sensor assembly	84 to * — All Models

# SOUND SYSTEM

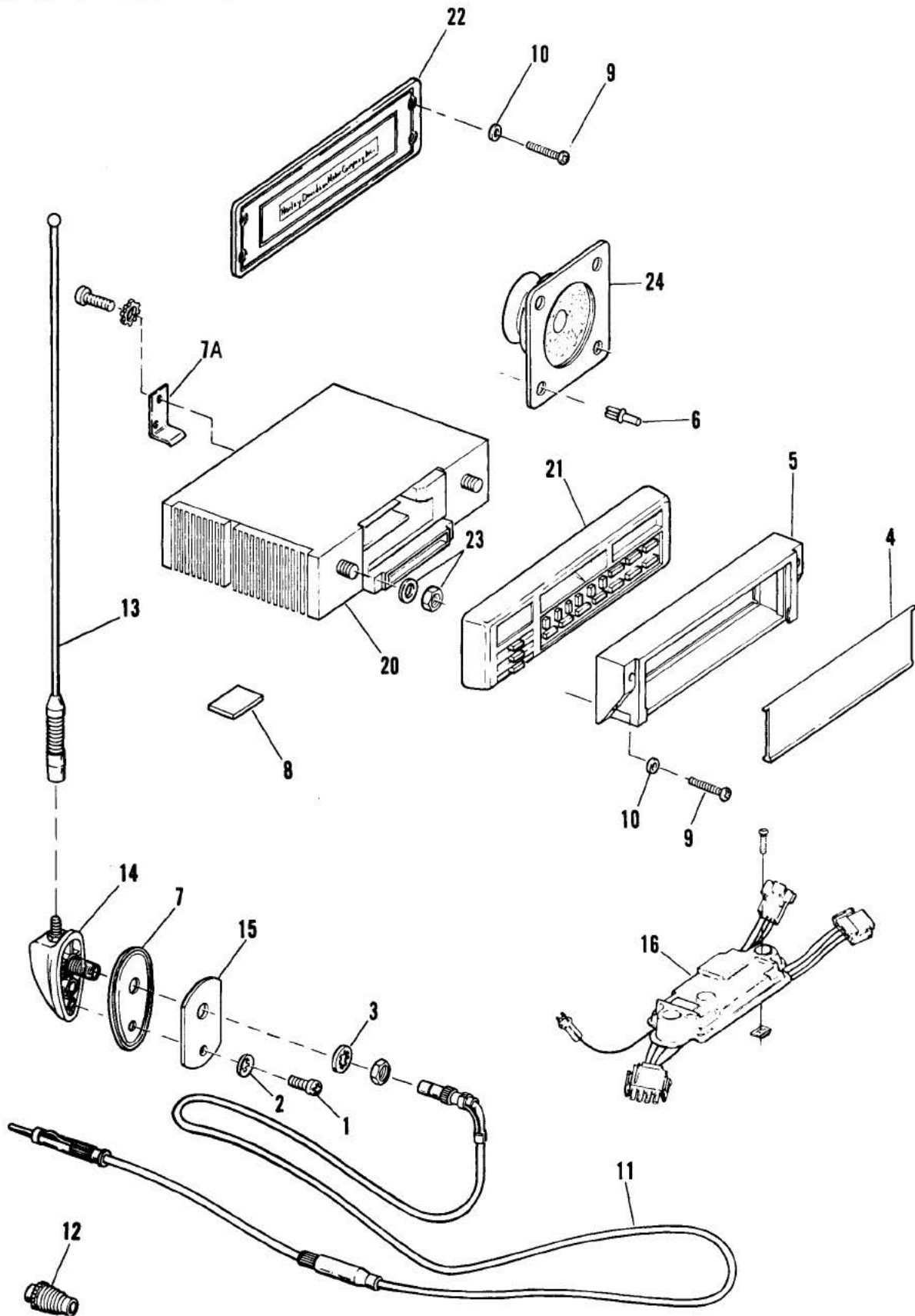

RETAIL PRICE	INDEX NO.	PART NO.	NAME	USED ON
	1	933	SCREW	86 to * — FXRD
	2	7118	LOCKWASHER	86 to * — FXRD
	3	7129	LOCKWASHER	86 to * — FXRD
	4	58661—86	DOOR, radio	86 to * — FXRD
	5	58662—86	HOOD, radio	86 to * — FXRD
	6	58709—86	RIVET (8)	86 to * — FXRD
		70149—86	WIRING HARNESS, radio terminal block (not illus.)	N/A 86 to * — FXRD
		70466—86	CABLE ASSEMBLY, antenna ground (not illus.)	86 to * — FXRD
	7	76169—86	GASKET BASE	86 to * — FXRD
	7A	76171—86	BRACKET, radio — rear	86 to * — FXRD
	8	76172—86	PAD, radio rear	86 to * — FXRD
	9	76243—86	SCREW (4)	86 to * — FXRD
	10	76244—86	WASHER (4)	86 to * — FXRD
	11	76248—86	CABLE, antenna	86 to * — FXRD
	12	76249—86	GROMMET	86 to * — FXRD
	13	76250—86A	ANTENNA	86 to * — FXRD
	14	76252—86	ANTENNA BASE, complete	86 to * — FXRD
	15	76253—86	REINFORCEMENT PLATE	86 to * — FXRD
	16	76262—86	TIMER CIRCUIT w/o AVC	Early 86 to * — FXRD
		76302—86	TIMER CIRCUIT w/AVC	86 to * — FXRD
	20	77008—86A	CHASSIS, radio	N/A 86 to * — FXRD
	21	77025—86	PANEL, control w/case	N/A 86 to * — FXRD
	22	77027—86	COVER	86 to * — FXRD
	23	77028—86	MOUNTING KIT	86 to * — FXRD
	24	77029—86	SPEAKER (2)	86 to * — FXRD
		77030—86	WIRING HARNESS, speaker (not illustrated)	86 to * — FXRD

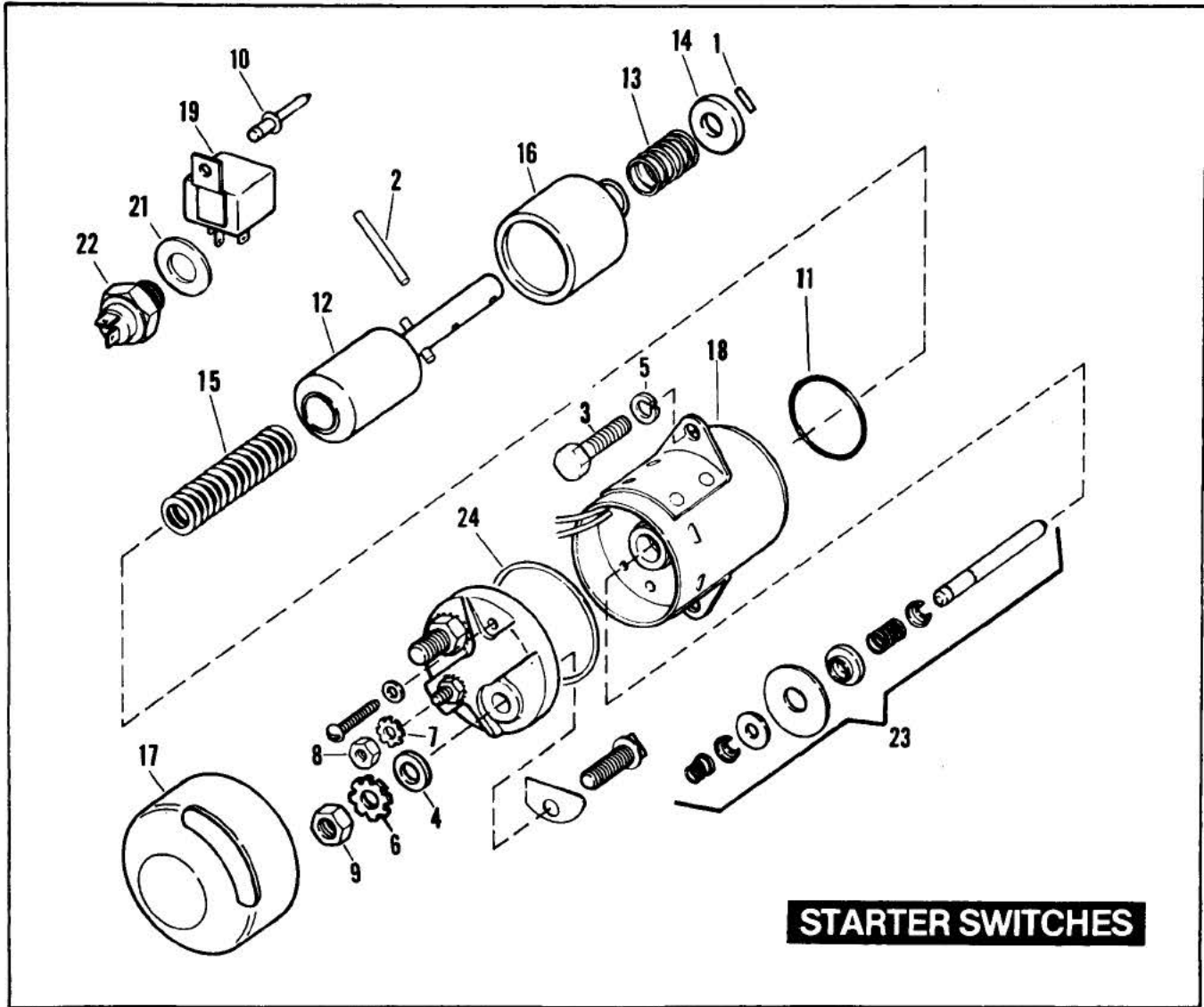

**STARTER SWITCHES**

# STARTER SWITCHES

RS44

RETAIL PRICE	INDEX NO.	PART NO.	NAME	USED ON
	1	256	PIN .....	84 & 85 — FXRS, FXRT
	2	614	ROLL PIN .....	84 to * — All Models
	3	3767B	BOLT (2) .....	84 to * — All Models
	4	6701	WASHER (2) .....	85 — FXRS, FXRT
	5	7036	LOCKWASHER (2) .....	84 to * — All Models
	6	7038	LOCKWASHER (2) .....	84 & Early 85 — FXRS, FXRT
		7145W	LOCKWASHER (2) .....	Late 85 to * — All Models
	7	7220	LOCKWASHER .....	84 to * — All Models
	8	7638	NUT .....	84 to * — All Models
	9	7667	LOCKNUT (2) .....	Late 85 to * — All Models
		7783	NUT (2) .....	84 & Early 85 — FXRS, FXRT
	10	8672	POP RIVET .....	Early 84 — FXRS, FXRT
	11	27060—55	O-RING .....	Early 84 — FXRS, FXRT
	12	31435—65B	PLUNGER ASSEMBLY, solenoid .....	84 to * — All Models
	13	31438—65A	OVER-RUN SPRING .....	84 to * — All Models
	14	31439—65A	RETAINER AND PIN, over-run spring .....	84 & Early 85 — FXRS, FXRT
		31439—84	RETAINER, over-run spring .....	Late 85 to * — All Models
	15	31440—65	RETURN SPRING, plunger .....	84 to * — All Models
	16	31441—65A	RUBBER BOOT, solenoid plunger .....	84 to * — FXRS, FXRT
	17	31444—65A	COVER, solenoid (rubber) .....	84 to * — FXRS, FXRT
	18	31489—79B	STARTER SOLENOID .....	84 to * — All Models
	19	31506—79B	STARTER RELAY .....	Early 84, Late 85 to * — All Models
	21	33043—80	WASHER, neutral indicator switch .....	84 to * — All Models
	22	33900—59	TRANSMISSION NEUTRAL SWITCH .....	84 to * — All Models
	23	71466—65	SOLENOID PLUNGER .....	N/A 84 to * — All Models
	24	71467—65	GASKET, solenoid cover .....	84 to * — All Models

# HANDLEBAR SWITCHES

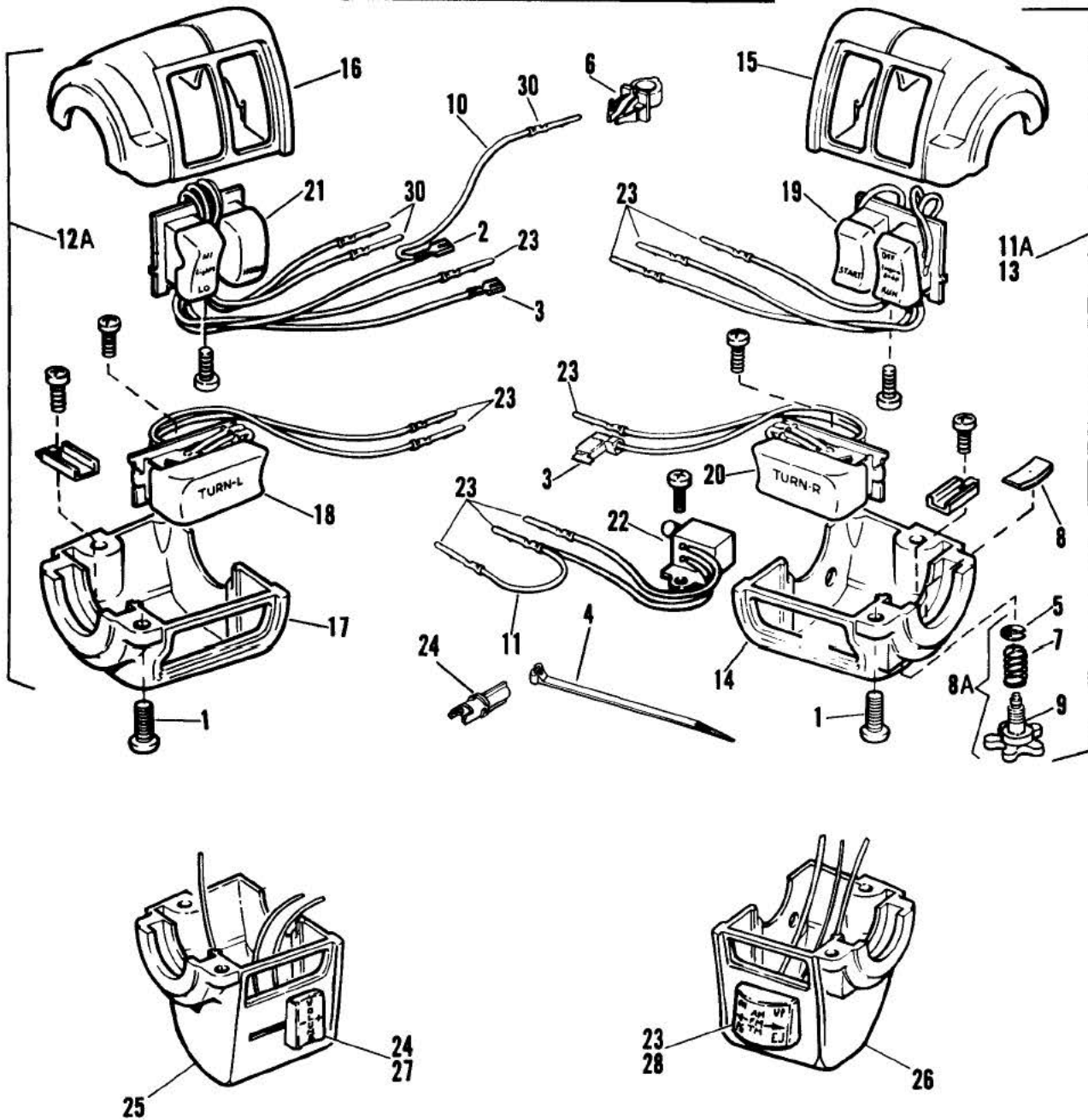



# HANDLEBAR SWITCHES

RS45

RETAIL PRICE	INDEX NO.	PART NO.	NAME	USED ON
	1	2508	SCREW (4)	84 to * — All Models
	2	9875	WIRE TERMINAL	84 to * — All Models
	3	9898	WIRE TERMINAL, insulated (2)	84 to * — All Models
	4	10007	CABLE STRAP (white)(2)	84 — FXRS, FXRT
		10065	STRAP, handlebar switches (2)	85 to * — All Models
	5	11155	RETAINING RING, adjusting screw	84 to * — All Models
	6	56073—83	RETAINER, wiring harness (4)	84 to * — All Models
	7	56394—74	SPRING, throttle adjusting screw	84 to * — All Models
	8	56396—74A	FRICTION SPRING, throttle grip	84 to * — All Models
	8A	56397—74C	ADJUSTING SCREW KIT, includes items 5, 7 & 9	84 to * — All Models
	9	56402—83A	ADJUSTING SCREW	84 to * — All Models
	10	70047—82	WIRE ASSEMBLY, 5' lg. (white)	84 to * — All Models
	11	70082—82	WIRE ASSEMBLY, 3' lg. (orange)	84 & 85 — FXRS, FXRT
	11A	70180—86	SWITCH KIT, complete — right	86 to * — FXRD
	12	70181—86	SWITCH KIT, complete — left	86 to * — FXRD
		70218—87	SWITCH KIT, complete — left	84 & 85 — FXRS, FXRT
		70218—86A	SWITCH KIT, complete — left	86 to * — FXR, FXRS, FXRT
	13	70219—87	SWITCH KIT, complete — right	84 & 85 — FXRS, FXRT
		70219—86A	SWITCH KIT, complete — right	86 to * — FXR, FXRS, FXRT
	14	71563—82A	HOUSING, lower — right	84 to * — FXR, FXRS, FXRT
	15	71564—82A	HOUSING, upper — right	84 to * — All Models
	16	71567—82	HOUSING, upper — left	84 to * — All Models
	17	71568—82A	HOUSING, lower — left	84 to * — FXR, FXRS, FXRT
	18	71570—86A	SWITCH ASSEMBLY — left directional	84 to * — All Models
	19	71571—82	SWITCH ASSEMBLY — engine stop & start	84 to * — All Models
	20	71572—86A	SWITCH ASSEMBLY — right directional	84 to * — All Models
	21	71573—82A	SWITCH ASSEMBLY — dimmer & horn	84 to * — All Models
	22	71574—82	STOPLIGHT SWITCH	84 to * — All Models
	23	71592—86	3-WAY FUNCTION SWITCH	86 to * — FXRD
	24	71593—86	VOLUME CONTROL	86 to * — FXRD
	25	71594—86	HOUSING, lower — left	86 to * — FXRD
	26	71595—86	HOUSING, lower — right	86 to * — FXRD
	27	71806—86	KNOB, volume	86 to * — FXRD
	28	71807—86	KNOB, on-off	86 to * — FXRD
	29	72038—71	SOCKET, single pin	86 to * — All Models
	30	72039—71	PIN, single socket (12)	84 to * — All Models
	31	72043—71	CONNECTOR, single pin	84 to * — All Models

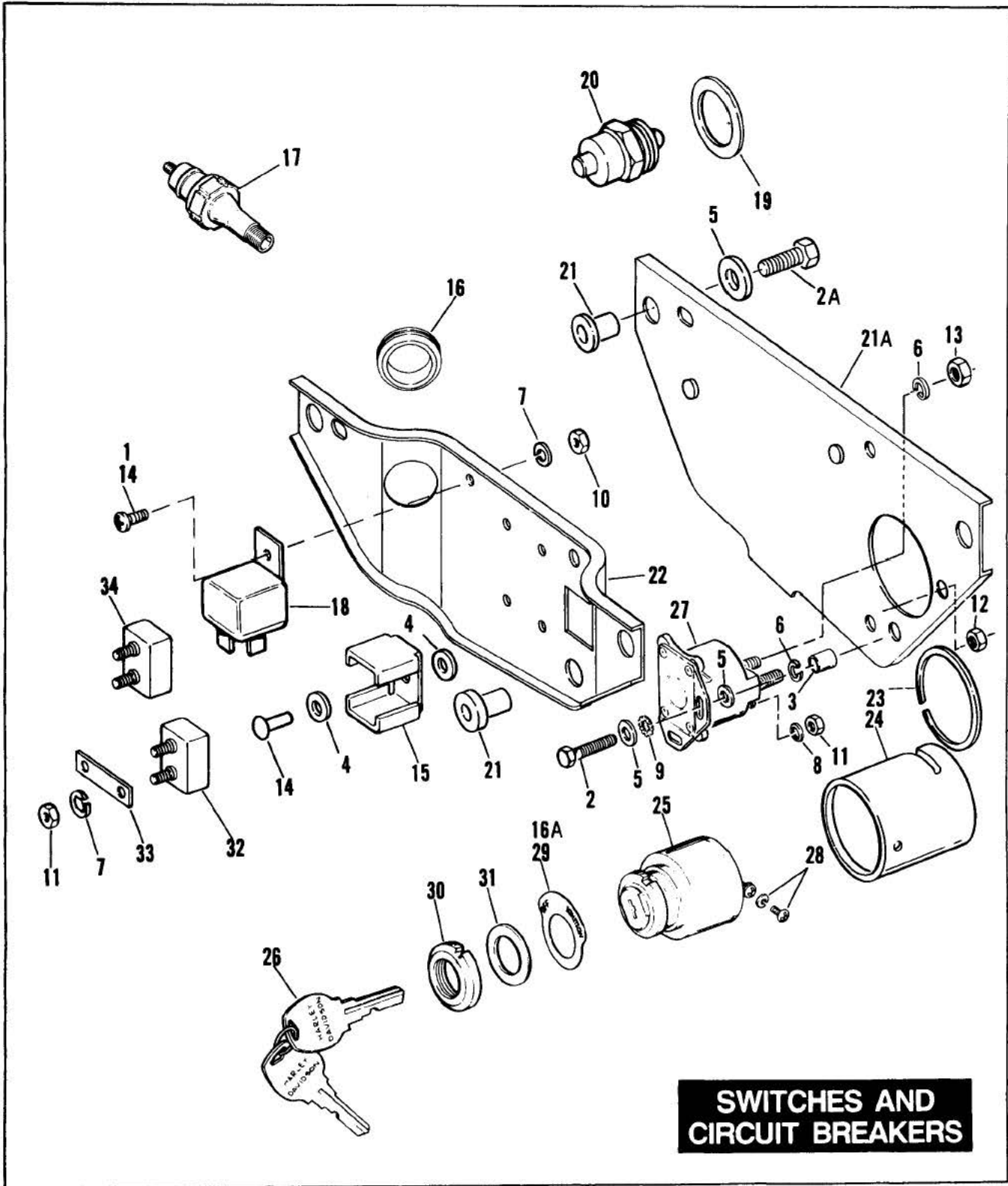

# SWITCHES AND CIRCUIT BREAKERS

RS46

RETAIL PRICE	INDEX NO.	PART NO.	NAME	USED ON
	1	2592	SCREW .....	Early 84 — FXRS, FXRT
	2	2872W	BOLT (2) .....	Late 84 & Early 85 — FXRS, FXRT
	2A	3787	BOLT (6) .....	Late 84 to * — All Models
	3	5733	SPACER (2) .....	Late 84 & Early 85 — FXRS, FXRT
	4	6192	WASHER (8) .....	85 to * — All Models
	5	6703	WASHER (10; 6 — Late 85 & Later) .....	Late 84 to * — All Models
	6	7041	LOCKWASHER (2) .....	Late 84 & Early 85 — FXRS, FXRT
	7	7069	LOCKWASHER (9; 8 — Late 84 & Early 85) .....	84 to * — All Models
	8	7220	LOCKWASHER .....	Late 84 & Early 85 — FXRS, FXRT
	9	7229W	LOCKWASHER (2) .....	Late 84 & Early 85 — FXRS, FXRT
	10	7620W	NUT .....	Early 84 — FXRS, FXRT
		7634	NUT (2) .....	Early 84 — FXRS, FXRT
	11	7638	NUT (8; 9 — Late 84 & Early 85; 12 — 86 & Later) ..	84 to * — FXRS, FXRT; 86 to * — FXRD
	12	7742	LOCKNUT (2) .....	Late 84 & Early 85 — FXRS, FXRT
	13	7748W	LOCKNUT (2) .....	Late 84 — FXRS, FXRT
		7763W	JAM NUT (2) .....	Early 85 — FXRS, FXRT
	14	8519	RIVET (4) .....	85 to * — All Models
		8672	RIVET (4; 5 — Late 85; 6 — 86 & Later) .....	84 & 85 — FXRS, FXRT; 86 to * — All Models
	15	9952	CLIP, circuit breaker (4) .....	84 to * — All Models
	16	11440	GROMMET .....	84 to * — All Models
	16A	14116—86	LABEL, ignition .....	86 to * — FXRT, FXRD
	17	26561—84	OIL PRESSURE SWITCH .....	84 to * — FXRS, FXRT; 86 to * — FXR
		74406—86	OIL PRESSURE SWITCH .....	86 to * — FXRD
	18	31506—79B	STARTER RELAY .....	Early 84 & Late 85 — FXRS, FXRT; 86 to * — All Models
	19	33043—80	WASHER, neutral indicator switch .....	84 to * — All Models
	20	33900—59	SWITCH, transmission neutral indicator .....	84 to * — All Models
	21	64511—63	WELL NUT (6) .....	Late 84 to * — All Models
	21A	70970—82C	IGNITION PANEL .....	84 to * — All Models
	22	70973—82A	ELECTRICAL PANEL .....	84 & 85 — FXRS, FXRT
		70979—86	ELECTRICAL PANEL .....	86 to * — All Models
	23	70974—84	SEAL .....	Late 84 & Early 85 — FXRS, FXRT
	24	71424—83	BOOT, ignition switch .....	84 to * — All Models
	25	71425—77	IGNITION SWITCH .....	84 to * — All Models
	26	71451—78	IGNITION KEYS (specify lock or key number) .....	84 to * — All Models
	27	71463—73A	RELAY, starter switch .....	Late 84 & Early 85 — FXRS, FXRT
	28	71518—80	SCREW, w/lockwasher (3) .....	84 to * — All Models
	29	71550—75	LABEL, ignition .....	84 to * — FXR, FXRS
	30	71552—75	FACE NUT, ignition and light switch .....	84 to * — All Models
	31	71554—75	WASHER, ignition and light switch .....	84 to * — All Models
	32	74589—73	CIRCUIT BREAKER (3; 5 — 86 & Later — FXRT, FXRD)	84 to * — All Models
	33	74598—73	CONNECTOR BAR, circuit breaker (2 — 86 & Later — FXRT, FXRD) .....	84 to * — All Models
	34	74599—77A	CIRCUIT BREAKER, battery .....	84 to * — All Models

**BATTERY**

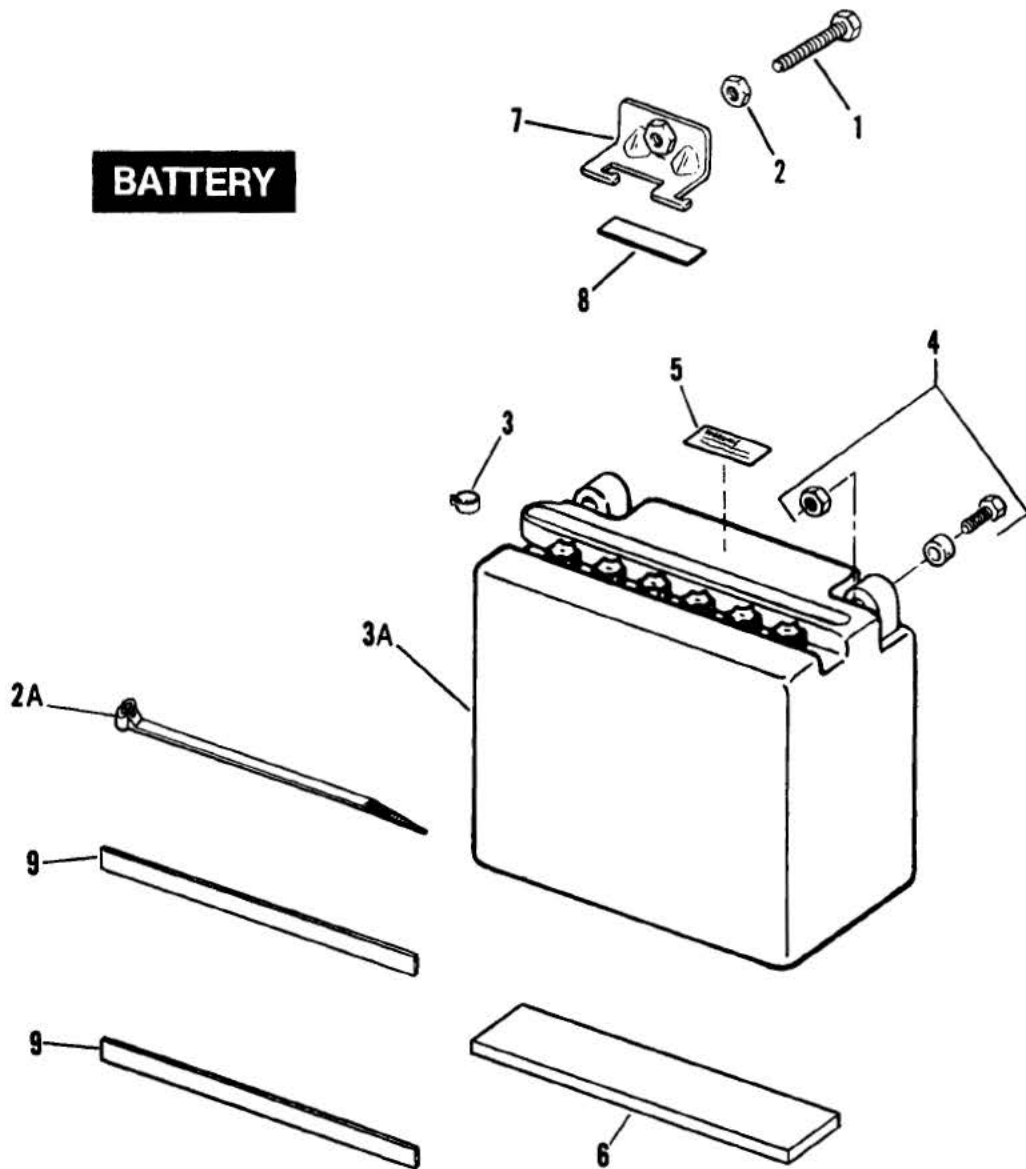

**BATTERY****RS47**

<b>RETAIL PRICE</b>	<b>INDEX NO.</b>	<b>PART NO.</b>	<b>NAME</b>	<b>USED ON</b>
	1	2796W	BOLT .....	84 to * — All Models
	2	7689W	NUT .....	84 to * — All Models
	2A	10039	CABLE STRAP .....	86 to * — All Models
	3	10067	CLAMP .....	Late 84 to * — All Models
	3A	65991—82A	BATTERY, includes item 2A .....	84 to * — All Models
	4	66000—80	BATTERY TERMINAL KIT .....	84 to * — All Models
	5	66042—79A	WARNING LABEL .....	84 to * — All Models
	6	66103—74A	PAD, battery .....	84 — FXRS, FXRT
		66104—84	PAD, battery (2) .....	85 to * — All Models
	7	66183—82	BRACKET, battery tie down .....	84 to * — All Models
	8	66188—82A	PAD .....	84 to * — FXRT
	9	67067—76	ISOLATOR (2) .....	84 to * — All Models

# SADDLEBAGS

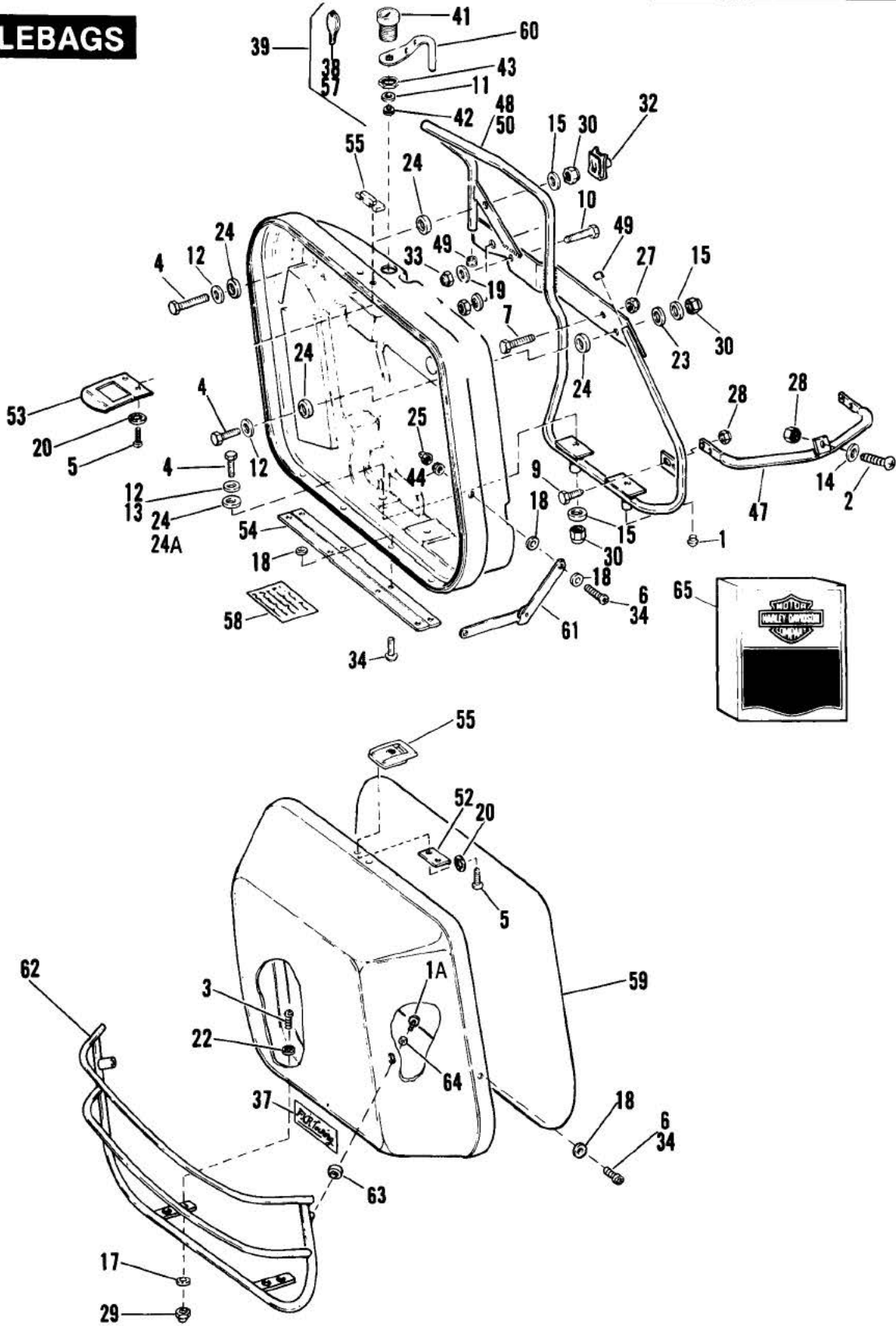

# SADDLEBAGS

RS48-1

RETAIL PRICE	INDEX NO.	PART NO.	NAME	USED ON
	1	735	PLUG, saddlebag bracket (4)	86 to * — FXRT
	1A	2337W	SCREW (4)	86 to * — FXRD
	2	2420	SCREW	84 — FXRT
		2607	SCREW	85 to * — FXRT; 86 to * — FXRD
	3	2774	SCREW (8)	86 to * — FXRD
	4	2790A	BOLT, w/lockpatch (8)	84 to * — FXRT; 86 to * — FXRD
	5	2804W	SCREW (8)	84 to * — FXRT; 86 to * — FXRD
	6	2806	SCREW (4)	85 to * — FXRT; 86 to * — FXRD
	7	2887W	BOLT (2)	84 to * — FXRT; 86 to * — FXRD
	9	3787	BOLT (4)	84 to * — FXRT; 86 to * — FXRD
	10	4412	BOLT (2)	84 to * — FXRT; 86 to * — FXRD
	11	6055	SPRING WASHER, curved (2)	85 to * — FXRT; 86 to * — FXRD
	12	6229W	WASHER (2; 6 — 86 & Later)	84 to * — FXRT; 86 to * — FXRD
	13	6333	WASHER (6; 2 — 86 & Later)	84 to * — FXRT; 86 to * — FXRD
	14	6410	WASHER	84 to * — FXRT; 86 to * — FXRD
	15	6702	WASHER (8 — 84 & 85)	84 & 85 — FXRT
	17	6703	WASHER (8)	86 to * — FXRT, FXRD
	18	6717	WASHER (24)	84 to * — FXRT; 86 to * — FXRD
	19	6774	WASHER (2)	84 to * — FXRT; 86 to * — FXRD
	20	7112	LOCKWASHER (8)	84 to * — FXRT; 86 to * — FXRD
	22	7124	LOCKWASHER (8)	86 to * — FXRD
	23	7130W	LOCKWASHER (2)	84 to * — FXRT; 86 to * — FXRD
	24	7415A	WASHER (16; 15 — 86 & Later)	84 to * — FXRT; 86 to * — FXRD
	24A	7419	WASHER — left side only	86 to * — FXRT, FXRD
	25	7520	ACORN NUT (4)	85 to * — FXRT; 86 to * — FXRD
	27	7531	NUT (2)	84 to * — FXRT; 86 to * — FXRD
	28	7686	LOCKNUT (5)	84 to * — FXRT; 86 to * — FXRD
	29	7737W	ACORN NUT (8)	86 to * — FXRD
	30	7739	LOCKNUT (8)	84 to * — FXRT; 86 to * — FXRD
	32	7752	SPEEDNUT (4)	86 to * — FXRT, FXRD
	33	7776W	LOCKNUT (2)	84 to * — FXRT; 86 to * — FXRD
	34	8508	RIVET (20)	Early 84 — FXRT
	35	8533	RIVET (16)	85 to * — FXRT; 86 to * — FXRD
	37	14053—83	DECAL, "FXR-Touring" (2)	84 & 85 — FXRT
	38	48152—82	KEY (specify key no. 1 to 100)	85 to * — FXRT; 86 to * — FXRD
	39	53589—86	LOCK SET, includes items 38 & 41-43	86 to * — FXRD
		53590—84	LOCK SET, includes items 38 & 41-43	Late 84 to * — FXRT
	41	53580—82	LOCK (2)	Late 84 to * — FXRT; 86 to * — FXRD
	42	53582—82	SCREW (2)	Late 84 to * — FXRT; 86 to * — FXRD
	43	84850—67	NUT, lock bracket (2)	Late 84 to * — FXRT; 86 to * — FXRD

# SADDLEBAGS

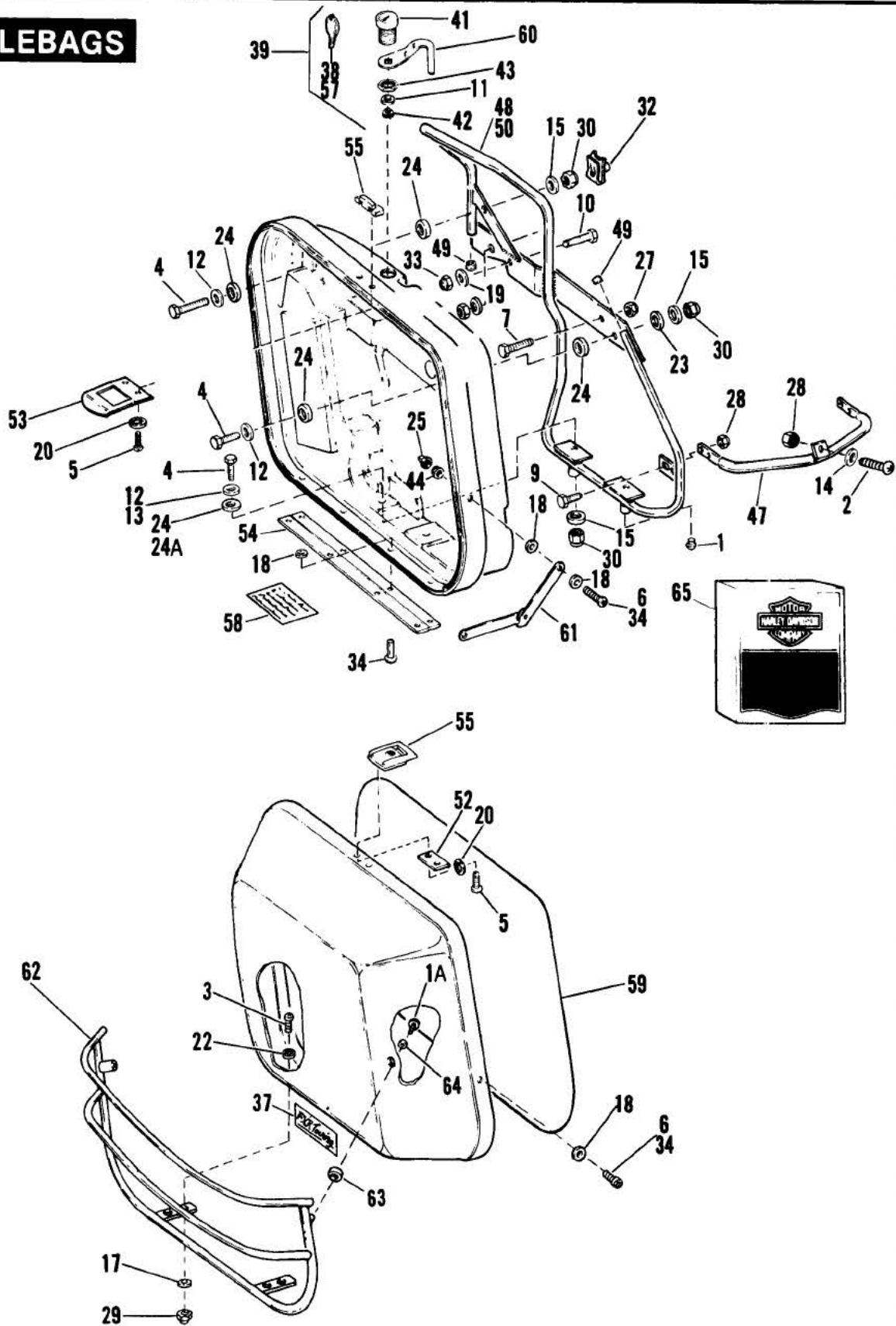



**SADDLEBAGS (CONT'D)**

**RS48-2**

RETAIL PRICE	INDEX NO.	PART NO.	NAME	USED ON
	44	60031-61	NUT (4)	85 to * - FXRT; 86 to * - FXRD
	47	90488-83	CROSSBRACE	84 to * - FXRT; 86 to * - FXRD
	48	90492-83	SUPPORT, saddlebag - left	84 & Early 85 - FXRT
		90492-86	SUPPORT, saddlebag - left	Late 85 to * - FXRT, FXRD
	49	90493-83	PLUG (4)	84 to * - FXRT; 86 to * - FXRD
	50	90499-85	SUPPORT, saddlebag - right	84 & 85 - FXRT
		90499-86	SUPPORT, saddlebag - right	86 to * - FXRT, FXRD
	52	90655-83	CATCH, lock (2)	84 to * - FXRT; 86 to * - FXRD
	53	90656-83	LATCH (2)	84 - FXRT
	54	90657-83A	HINGE (2)	N/A Early 84 - FXRT
		90657-84	HINGE (2)	Late 84 to * - FXRT; 86 to * - FXRD
	55	90658-83	LOCK (2 piece)(2)	84 - FXRT
		90658-84	LOCK (2)	85 to * - FXRT; 86 to * - FXRD
	57	90659-83	KEY (indicate serial no.)	84 - FXRT
	58	90683-83	LABEL, saddlebag load limit (2)	84 to * - FXRT; 86 to * - FXRD
	59	90685-83	SEAL, cover (2)	84 to * - FXRT; 86 to * - FXRD
	60	90689-84	LOCKING HOOK (2)	84 to * - FXRT; 86 to * - FXRD
	61	90699-83	RETAINER ARM, cover (2)	84 to * - FXRT; 86 to * - FXRD
	62	90864-85	GUARD, saddlebag - right	86 to * - FXRD
		90866-85	GUARD, saddlebag - left	86 to * - FXRD
	63	90869-85	PAD, rod mounting (4)	86 to * - FXRD
	64	91795-85	WASHER (4)	86 to * - FXRD
	65	91836-82	TRAVEL BAG, large (2)	84 to * - FXRT; 86 to * - FXRD

RETAIL PRICE	INDEX NO.	PART NO.	NAME	USED ON
			NOTE: This kit is for 1985 and later FXR model motorcycles for use in the state of California.	
		3787	BOLT (4)	85 to * — All Models
		6703	WASHER (6)	85 to * — All Models
		7686	LOCKNUT (4)	85 to * — All Models
		8625	RIVET (2)	85 — FXRS, FXRT
		10006	STRAP (6)	85 to * — All Models
		27018—85	CLAMP	85 to * — All Models
		27042—84	CANISTER	85 to * — All Models
		27047—84	BRACKET, canister mounting	85 to * — All Models
		27048—84	CLAMP, canister down tube (2)	85 to * — All Models
		27065—85	HOSE FITTING, flanged	85 — FXRS, FXRT
		27068—85	GASKET, fitting — air cleaner	N/A 85 — FXRS, FXRT
		27073—84A	HOSE, canister to tank	85 to * — All Models
		27074—84	HOSE, canister to carburetor	85 to * — All Models
		27075—84	HOSE, canister to air cleaner	85 — FXRS, FXRT
		28807—85	EVAPORATIVE EMISSIONS KIT, complete	N/A 85 — FXRS, FXRT
		28807—86	EVAPORATIVE EMISSIONS KIT, complete	Early 86 — All Models
		28813—86	EVAPORATIVE EMISSIONS KIT, complete	Late 86 to * — All Models
		28815—86	HOSE, canister to air cleaner	86 to * — All Models
		29058—77	GASKET, carburetor inlet	85 — FXRS, FXRT
		29121—84	CAP, overflow	85 to * — All Models
		29141—85	VENT TUBE, carburetor bowl	N/A 85 — FXRS, FXRT
		29264—86	FITTING	86 to * — All Models
		62150—85	VAPOR VALVE	85 to * — All Models

<b>RETAIL PRICE</b>	<b>INDEX NO.</b>	<b>PART NO.</b>	<b>NAME</b>	<b>USED ON</b>
<b>ROCKER ARMS, COVER &amp; PUSHROD — V™</b>				
	17528—84		ROCKER COVER, outer (chrome)(2)	Late 84 to * — FXRDG
	17529—84A		SPACER, rocker covers (chrome)(2)	Late 84 to * — FXRDG
	17530—84A		ROCKER COVER, inner (chrome)(2)	Late 84 to * — FXRDG
<b>CRANKCASE — GEAR SIDE</b>				
	25268—84A		GEAR COVER (chrome)	Late 84 to * — FXRDG
<b>TRANSMISSION HOUSING</b>				
	34466—82		COVER, upper (chrome)	Late 84 to * — FXRDG
	37104—84		CLUTCH RELEASE COVER ASSEMBLY, includes oil seal & bushing (chrome)	Late 84 to * — FXRDG
<b>FRONT CHAIN HOUSING</b>				
	60665—84		COVER, chain housing (w/9063 BEARING)(chrome)	Late 84 to * — FXRDG
	60667—84		INSPECTION COVER (chrome)	N/A Late 84 to * — FXRDG
	60668—84A		COVER, clutch (chrome)	Late 84 to * — FXRDG
<b>FRONT WHEEL</b>				
	43024—73B		SPOKE AND NIPPLE, 19 in. rim — short (metric)(20)	Late 84 to * — FXRDG
	43025—73B		SPOKE AND NIPPLE, 19 in. rim — long (metric)(20)	Late 84 to * — FXRDG
	43312—84		WHEEL ASSEMBLY, laced	Late 84 to * — FXRDG
<b>REAR WHEEL</b>				
	41057—83		DISC WHEEL ASSEMBLY, w/bearings	Late 84 to * — FXRDG
<b>SEAT</b>				
	52440—84		SEAT, front	N/A Late 84 to * — FXRDG
	52441—84		SEAT, rear	N/A Late 84 to * — FXRDG
<b>FENDER</b>				
	59010—84		FRONT FENDER (burgundy & black)	Late 84 to * — FXRDG
	59605—84		REAR FENDER (burgundy & black)	Late 84 to * — FXRDG
<b>FUEL TANK</b>				
	61085—84		FUEL TANK (burgundy & black)	Late 84 to * — FXRDG

RETAIL PRICE	INDEX NO.	PART NO.	NAME	USED ON
<b>ROCKER ARMS, COVER &amp; PUSHROD — V™</b>				
		17528—84	ROCKER COVER, outer (chrome) (2) .....	Late 85 — FXRC
		17529—84A	SPACER, rocker covers (chrome) (2) .....	Late 85 — FXRC
		17530—84A	ROCKER COVER, inner (chrome) (2) .....	Late 85 — FXRC
<b>CRANKCASE — GEAR SIDE</b>				
		25268—84A	GEAR COVER (chrome) .....	Late 85 — FXRC
			Consists of besides gear cover:	
		2511	SCREW, breather cover	
		25275—82	COVER, breather	
		83162—51	OIL SEAL, bearing	
<b>TRANSMISSION HOUSING</b>				
		34466—82	COVER, upper (chrome) .....	Late 85 — FXRC
		37075—84	FILL PLUG, with dipstick (polished) .....	Late 85 — FXRC
		37104—84	CLUTCH RELEASE COVER ASSEMBLY (chrome) .....	Late 85 — FXRC
<b>FRONT WHEEL</b>				
		43001—79	RIM, 19" (chrome) .....	Late 85 — FXRC
		43024—73B	SPOKE AND NIPPLE SET, 19" rim — short (metric) (20) .....	Late 85 — FXRC
		43025—73B	SPOKE AND NIPPLE SET, 19" rim — long (metric) (20) .....	Late 85 — FXRC
		43312—84	WHEEL ASSEMBLY, 19" — laced .....	Late 85 — FXRC
		43619—84	HUB ASSEMBLY .....	Late 85 — FXRC
			Consists of besides hub:	
		9052	BEARING (2)	
		43358—83A	SPACER, bearing	
		43623—78	SLEEVE, bearing — 2.564" (violet)	
		43624—78	SLEEVE, bearing — 2.550" (pink)	
		43625—78	SLEEVE, bearing — 2.536" (gold)	
		47519—83A	OIL SEAL (2)	
		95578—41	WHEEL WEIGHT, 1/2 oz. — 0.275 I.D. (round) .....	Late 85 — FXRC
		95581—47	WHEEL WEIGHT, 3/4 oz. — 0.275 I.D. (round) .....	Late 85 — FXRC
		95582—47	WHEEL WEIGHT, 1 oz. — 0.275 I.D. (round) .....	Late 85 — FXRC

RETAIL PRICE	INDEX NO.	PART NO.	NAME	USED ON
<b>REAR WHEEL &amp; CHAIN OR BELT GUARD</b>				
	4726		SCREW, sprocket mounting (5) .....	Late 85 — FXRC
	6516HW		WASHER, sprocket mounting (5) .....	Late 85 — FXRC
	7561		LOCKNUT, sprocket mounting (5) .....	Late 85 — FXRC
	7778		LOCKNUT, disc mounting (5) .....	Late 85 — FXRC
	40951—82		WHEEL ASSEMBLY, 16" — laced .....	Late 85 — FXRC
	43032—40B		SPOKE AND NIPPLE SET, 16" rim (40) .....	Late 85 — FXRC
	40952—82A		HUB ASSEMBLY .....	Late 85 — FXRC
			Consists of besides hub:	
	9052		BEARING (2)	
	43601—78A		SPACER, flanged — 4.420" (orange)	
	43602—78A		SPACER, flanged — 4.434" (yellow)	
	43603—78A		SPACER, flanged — 4.448" (white)	
	43654—86A		SPACER, right	
	47519—83A		OIL SEAL (2)	
	43085—81		RIM, 16" (chrome) .....	Late 85 — FXRC
	43567—79		SCREW, disc mounting (5) .....	Late 85 — FXRC
	54321—85		HEX NUT, valve stem .....	Late 85 — FXRC
	95581—47		WHEEL WEIGHT, 3/4 oz. — 0.275" I.D. (round) .....	Late 85 — FXRC
	95582—47		WHEEL WEIGHT, 1 oz. — 0.275" I.D. (round) .....	Late 85 — FXRC
<b>FRONT FORK</b>				
	45423—85		DECAL, fork cover "CUSTOM" .....	N/A Late 85 — FXRC
<b>SEAT AND SISSYBAR</b>				
	52132—85		PASSENGER STRAP .....	N/A Late 85 — FXRC
	52136—85		SEAT, rear (brown vinyl) .....	N/A Late 85 — FXRC
	52143—85		SEAT, front (brown vinyl) .....	N/A Late 85 — FXRC
<b>HANDLEBAR AND THROTTLE CONTROL</b>				
	56111—85		CLAMP, handlebar — right (polished) .....	Late 85 — FXRC
	56112—85		CLAMP, handlebar — left (polished) .....	Late 85 — FXRC
	56115—77		UPPER CLAMP, handlebar .....	Late 85 — FXRC
<b>FENDERS AND LICENSE PLATE BRACKETS</b>				
	59514—85		TRIM, rear fender support — right (brown) .....	N/A Late 85 — FXRC
	59516—85		TRIM, rear fender support — left (brown) .....	Late 85 — FXRC
<b>PRIMARY HOUSING</b>				
	60665—85B		COVER ASSEMBLY (chrome) .....	Late 85 — FXRC
			Consists of besides cover:	
	739		PLUG, belt cover (magnetic)	
	9063		NEEDLE BEARING	
	60667—85		INSPECTION COVER (chrome) .....	Late 85 — FXRC
	60668—84A		COVER, clutch (chrome) .....	Late 85 — FXRC

# NOTES

RETAIL PRICE	INDEX NO.	PART NO.	NAME	USED ON
<b>AIR CLEANER</b>				
	29166—86		TRIM, air cleaner — “Low Rider Sport” .....	86 to * — FXRS
<b>FRONT BRAKE CONTROL</b>				
See Pages 142 & 143				
<b>FRONT BRAKE CALIPER</b>				
See Pages 144 & 145				
<b>FRONT WHEEL</b>				
See Pages 146 & 147				
<b>FRONT FORK</b>				
See Pages 148 & 149				
<b>INSTRUMENTS</b>				
	67048—83A		CABLE ASSEMBLY, speedometer drive .....	85 to * — FXRS
<b>SHOCK ABSORBERS</b>				
See Pages 150 & 151				
<b>FRAME, REAR FORK &amp; JIFFY STAND</b>				
	50069—84		JIFFY STAND .....	85 — FXRS
	50069—86		JIFFY STAND .....	86 to * — FXRS

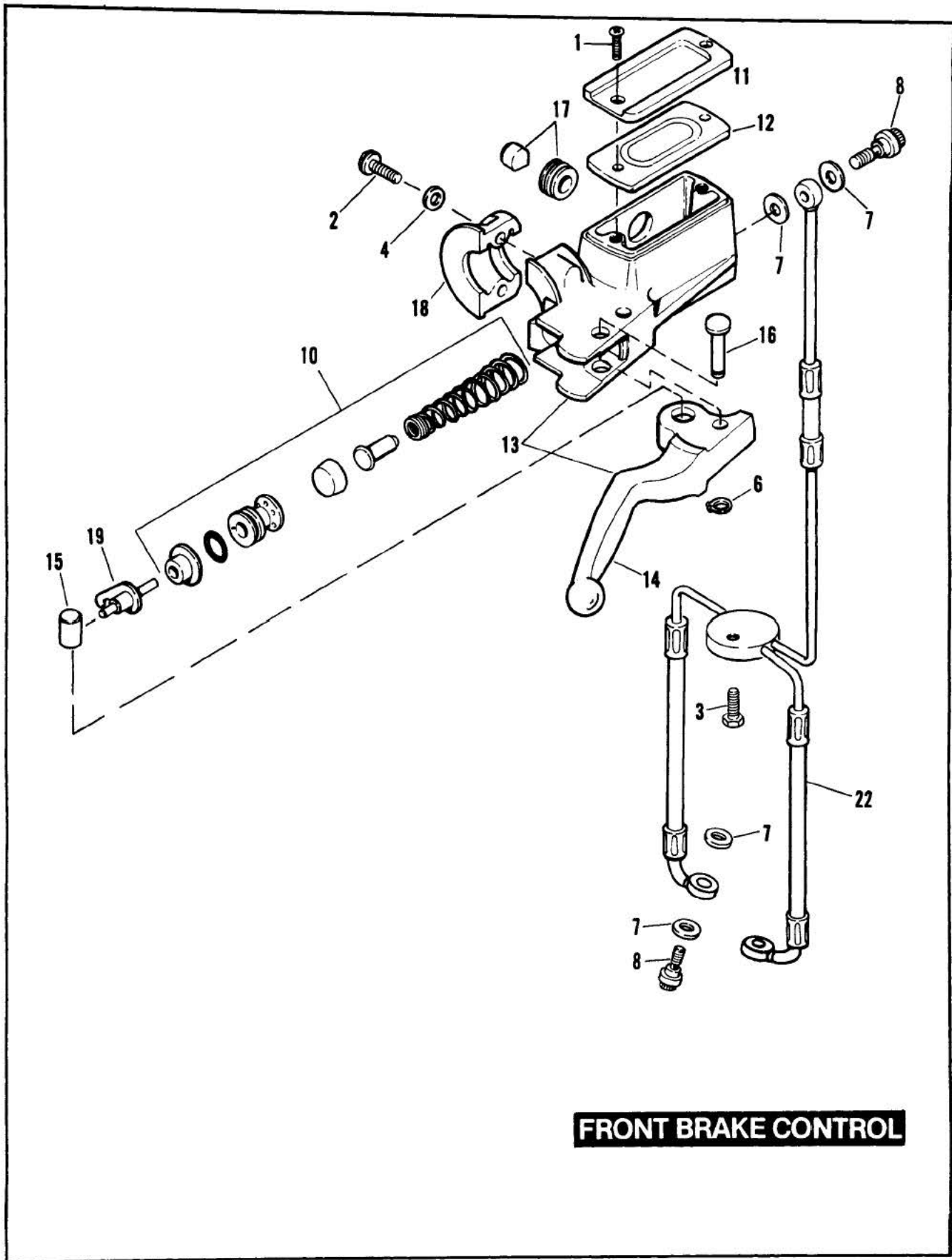

**FRONT BRAKE CONTROL**



# FRONT BRAKE CONTROL

RS52-2

RETAIL PRICE	INDEX NO.	PART NO.	NAME	USED ON
	1	2579	SCREW (2)	85 to * — FXRS
	2	4015	SCREW (2)	85 to * — FXRS
	3	4812	SCREW	85 to * — FXRS
	4	6099	WASHER (2)	85 to * — FXRS
	5	11143	RETAINING RING, external	85 to * — FXRS
	7	41731—82	GASKET, brake line to caliper (6)	85 to * — FXRS
	8	41747—82A	FITTING, brake line to caliper (3)	85 to * — FXRS
	10	45006—87	REPAIR KIT, master cylinder	85 to * — FXRS
	11	45004—85	COVER, master cylinder	85 to * — FXRS
	12	45005—85	GASKET, master cylinder cover	85 to * — FXRS
	13	45013—85	MASTER CYLINDER ASSEMBLY, with hand lever	85 to * — FXRS
	14	45016—82	HAND LEVER	85 to * — FXRS
	15	45031—82	PIN, stoplight switch & push rod	85 to * — FXRS
	16	45032—82	PIN, hand lever pivot	85 to * — FXRS
	17	45042—82	WINDOW, fluid level, with grommet	85 to * — FXRS
	18	45044—82	CLAMP, master cylinder	85 to * — FXRS
	19	45051—82	PUSH ROD, stoplight switch & master cylinder	85 to * — FXRS
	22	45136—85	BRAKE LINE	85 to * — FXRS

# FRONT BRAKE CALIPER

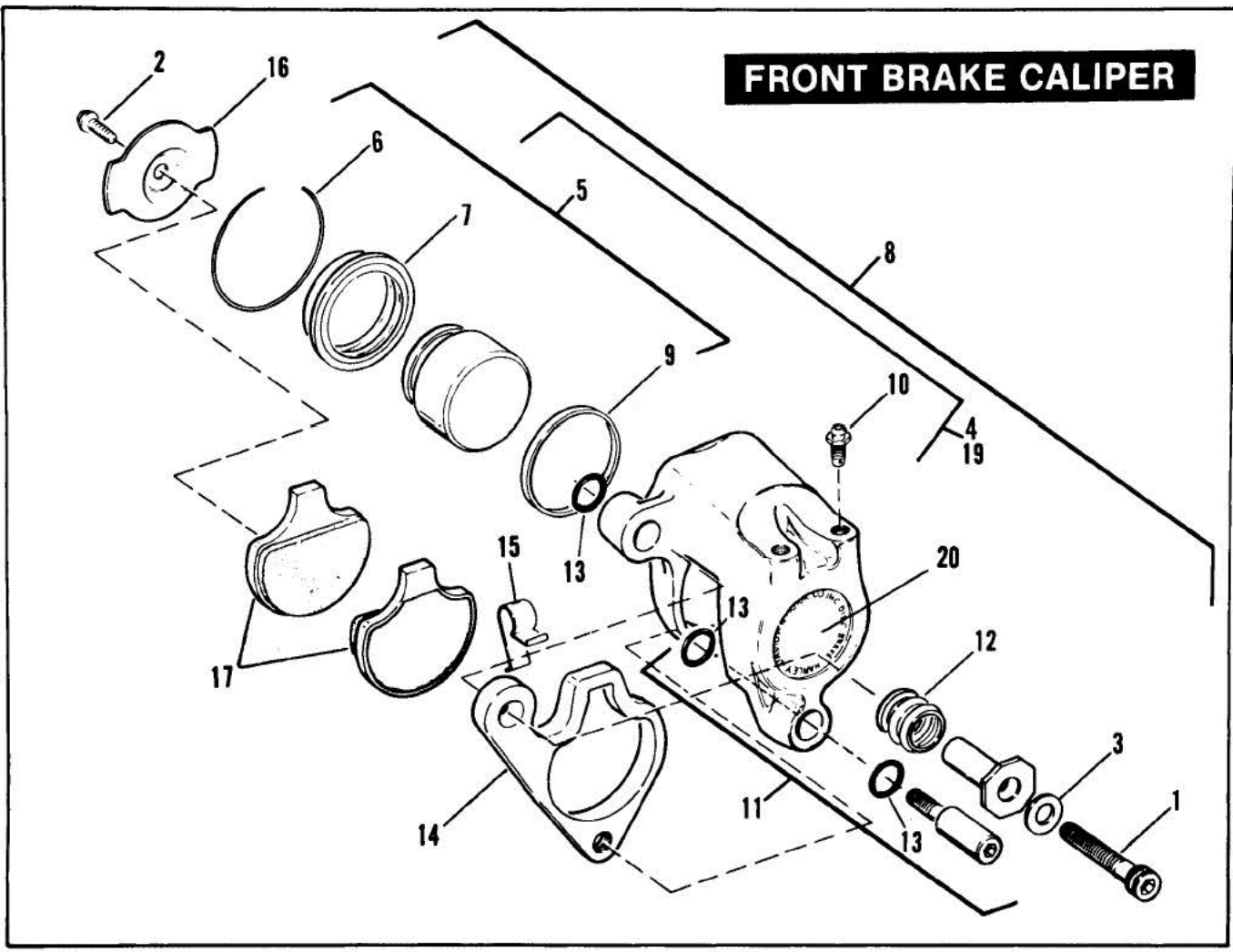

# FRONT BRAKE CALIPER

RS52-3

RETAIL PRICE	INDEX NO.	PART NO.	NAME	USED ON
	1	855	SCREW (2)	85 to * — FXRS
	2	3517	SCREW (2)	85 to * — FXRS
	3	6019	WASHER (2)	85 to * — FXRS
	4	44019—83	CALIPER REBUILD KIT, includes items 5 & 10 — right	85 to * — FXRS
	5	44020—83	PISTON REBUILD KIT, includes items 6, 7 & 9 (2)	85 to * — FXRS
	6	44021—83	RETAINING RING, piston (2)	85 to * — FXRS
	7	44022—83	DUST BOOT, piston (2)	85 to * — FXRS
	8	44023—83	CALIPER ASSEMBLY, right	85 to * — FXRS
		44046—84	CALIPER ASSEMBLY, left	85 to * — FXRS
	9	44047—83	SEAL, piston (2)	85 to * — FXRS
	10	44048—83	BLEEDER FITTING (2)	85 to * — FXRS
	11	44053—83A	GUIDE PIN KIT, includes items 12 & 13 (2)	85 to * — FXRS
	12	44054—83	PIN BOOT (2)	85 to * — FXRS
	13	44059—83	O-RING (6)	85 to * — FXRS
	14	44060—83	BRACKET, caliper mounting (2)	85 to * — FXRS
	15	44061—83	SPRING CLIP (2)	85 to * — FXRS
	16	44062—83	RETAINING PAD (2)	85 to * — FXRS
	17	44063—83	PAD SET, includes item 2 (2)	85 to * — FXRS
	19	44065—83	CALIPER REBUILD KIT, includes items 5 & 10 — left	N/A
	20	44197—77	LABEL (2)	85 to * — FXRS

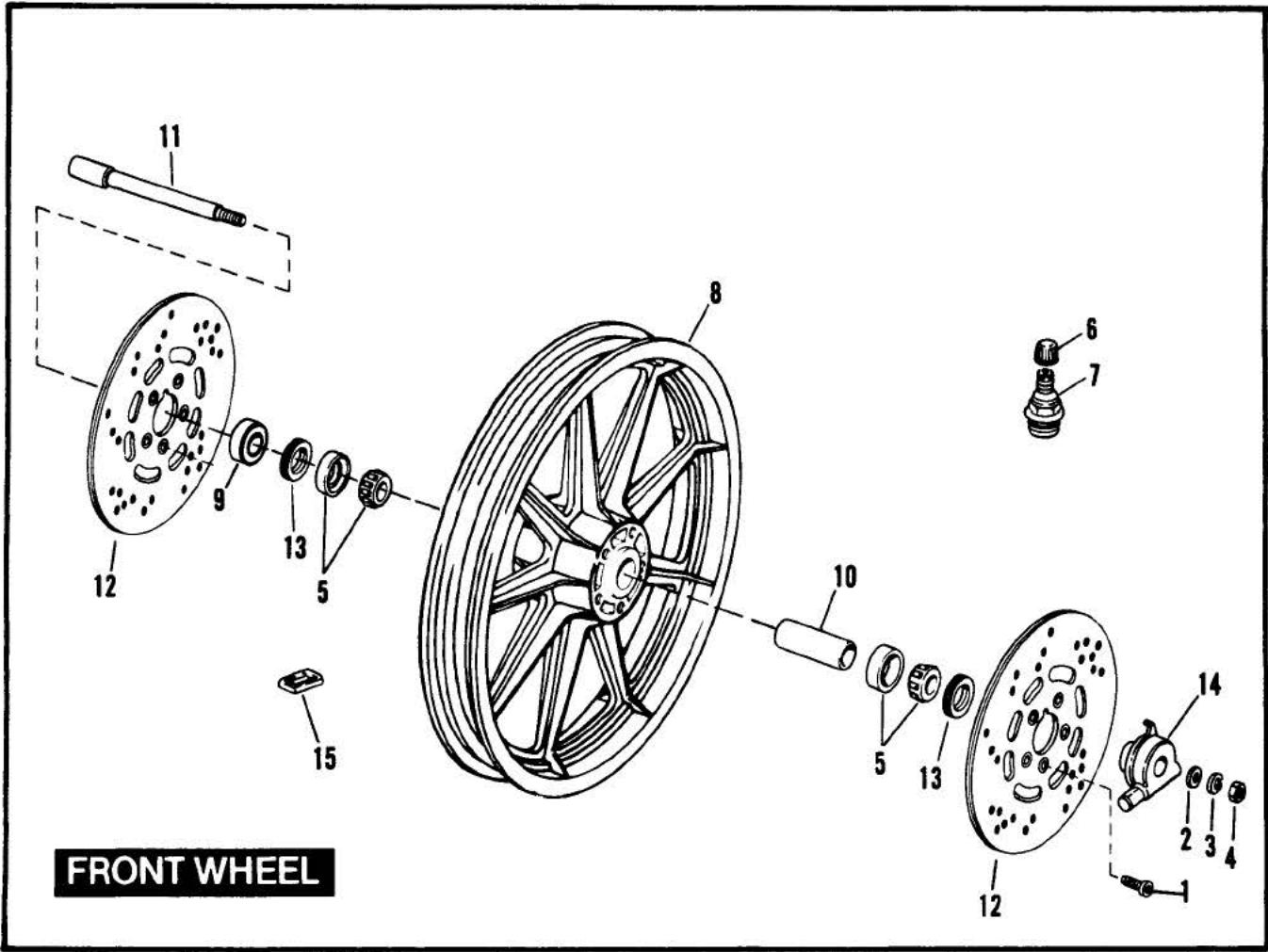

# FRONT WHEEL

RS52-4

RETAIL PRICE	INDEX NO.	PART NO.	NAME	USED ON
	1	3655	SCREW (10) .....	85 to * — FXRS
	2	6653	WASHER .....	85 to * — FXRS
	3	7022	LOCKWASHER .....	85 to * — FXRS
	4	7813	NUT .....	85 to * — FXRS
	5	9052	BEARING (2) .....	85 to * — FXRS
	6	41123—79	VALVE CAP .....	85 to * — FXRS
	7	43150—83	VALVE STEM ASSEMBLY .....	85 to * — FXRS
	8	43338—83	CAST WHEEL ASSEMBLY, 19" w/bearings, seals, and spacers (silver) .....	85 to * — FXRS
	9	43358—83A	SPACER, bearing .....	85 to * — FXRS
	10	43623—78	SLEEVE, between bearings 2.564" (violet) .....	85 to * — FXRS
		43624—78	SLEEVE, between bearings 2.550" (pink) .....	85 to * — FXRS
		43625—78	SLEEVE, between bearings 2.536" (gold) .....	85 to * — FXRS
	11	43883—84	AXLE, front .....	85 to * — FXRS
	12	44136—84A	DISC, brake (2) .....	85 to * — FXRS
	13	47519—83A	OIL SEAL (2) .....	85 to * — FXRS
	14	67127—84A	DRIVE, speedometer .....	85 to * — FXRS
	15	95595—84	WEIGHT, 0.25 oz. (silver) .....	85 to * — FXRS

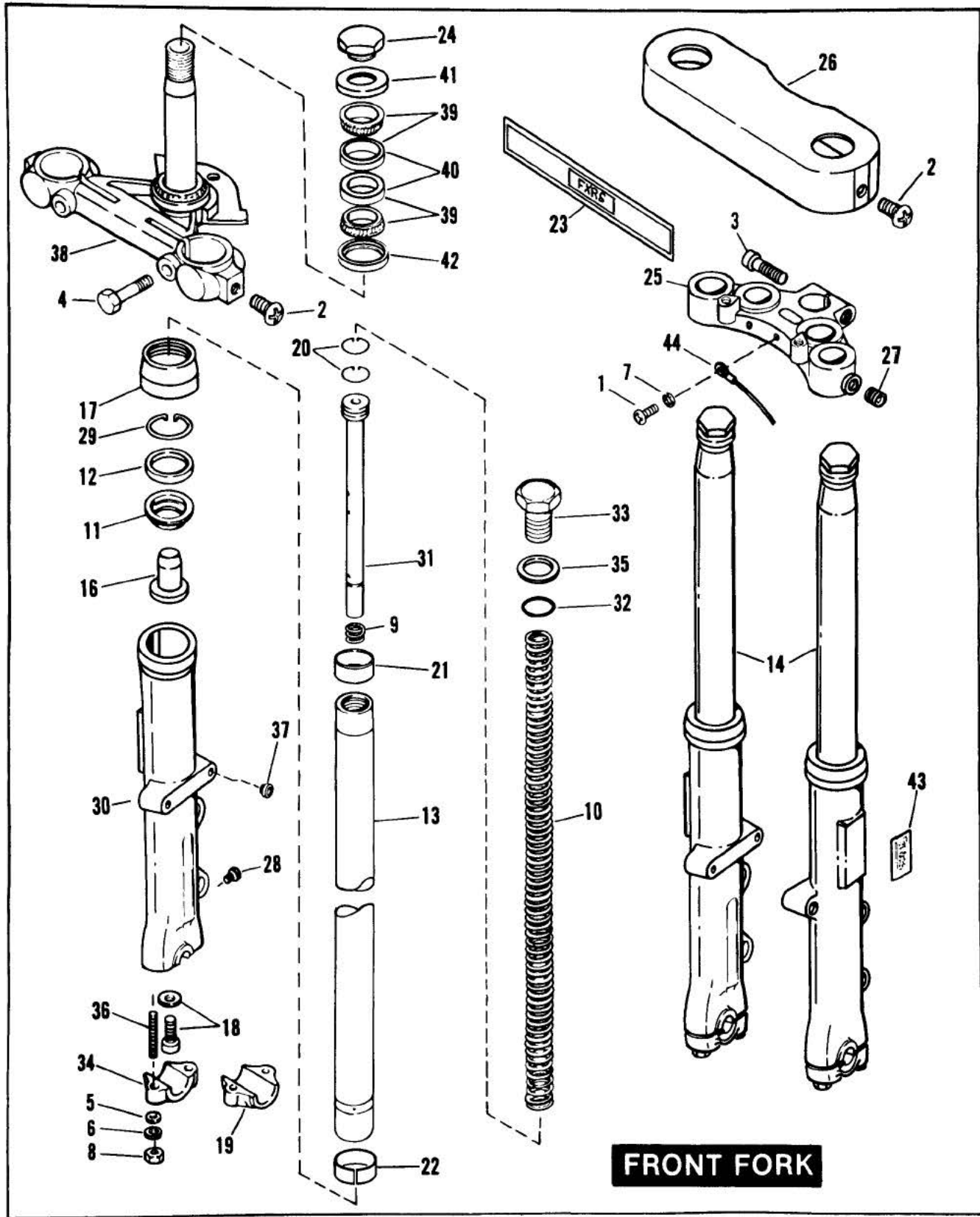

RETAIL PRICE	INDEX NO.	PART NO.	NAME	USED ON
	1	2662W	SCREW (2)	85 to * — FXRS
	2	2823	SCREW (4)	85 to * — FXRS
	3	4371W	BOLT	85 to * — FXRS
	4	4724	BOLT (2)	85 to * — FXRS
	5	6702	WASHER (4)	85 to * — FXRS
	6	7041	LOCKWASHER (4)	85 to * — FXRS
	7	7220	LOCKWASHER (2)	85 to * — FXRS
	8	7748W	NUT (4)	85 to * — FXRS
	9	45382—83	SPRING, slider (2)	85 to * — FXRS
	10	45385—83	SPRING (2)	85 to * — FXRS
	11	45386—83	SPACER, seal (2)	85 to * — FXRS
	12	45387—83	OIL SEAL, slider (2)	85 to * — FXRS
	13	45392—83	SLIDER TUBE (2)	85 & Early 86 — FXRS
		45392—86	SLIDER TUBE (2)	Late 86 to * — FXRS
	14	45398—84A	FORK SLIDER & TUBE assembly, right	85 to * — FXRS
		45399—84A	FORK SLIDER & TUBE ASSEMBLY, left	85 to * — FXRS
	16	45403—84	LOWER STOP (2)	85 to * — FXRS
	17	45404—75	DUST COVER (2)	85 to * — FXRS
	18	45405—75A	SCREW WITH WASHER, damper tube (2)	85 to * — FXRS
	19	45410—84	AXLE CAP, left slider	85 to * — FXRS
	20	45412—75	RING, damper tube (4)	85 to * — FXRS
	21	45413—84	BUSHING, upper — fork slide (2)	85 to * — FXRS
	22	45416—84	BUSHING, lower — fork slider (2)	85 to * — FXRS
	23	45429—84	NAMEPLATE "FXRS"	85 to * — FXRS
	24	45718—71	NUT, fork stem	85 to * — FXRS
	25	45736—78B	BRACKET, upper	85 to * — FXRS
	26	45751—71A	COVER, fork	85 to * — FXRS
	27	45782—72A	SCREW INSERT (2)	85 to * — FXRS
	28	45790—80	DRAIN SCREW, SLIDER (2)	85 to * — FXRS
	29	45908—80	RETAINING RING, oil seal (2)	85 to * — FXRS
	30	45909—83	SLIDER, right	85 to * — FXRS
		45912—84	SLIDER, left	85 to * — FXRS
	31	45913—84	DAMPER TUBE, includes item 20 (2)	85 to * — FXRS
	32	45982—73	O-RING, slider tube cap (2)	85 to * — FXRS
	33	45993—73	CAP, slider tube (2)	85 & Early 86 — FXRS
		45993—86	CAP, slider tube (2)	Late 86 to * — FXRS
	34	45994—84	AXLE CAP, right slider	85 to * — FXRS
	35	45997—73	WASHER, slider tube cap (2)	85 to * — FXRS
	36	45998—73	STUD (4)	85 to * — FXRS
	37	46020—84	BUSHING, brake caliper (2)	85 to * — FXRS
	38	47693—84	BRACKET, lower - w/bearing and shield	85 to * — FXRS
	39	48300—60	ROLLER BEARING, w/cup (2)	85 to * — FXRS
	40	48315—60	BEARING CUP (2)	85 to * — FXRS
	41	48361—80	DUST SHIELD, head bearing - upper	85 to * — FXRS
	42	48365—48A	DUST SHIELD, head bearing - lower	85 to * — FXRS
	43	59254—72	REFLECTOR (amber)(2)	85 to * — FXRS
	44	70191—73A	CABLE	85 to * — FXRS

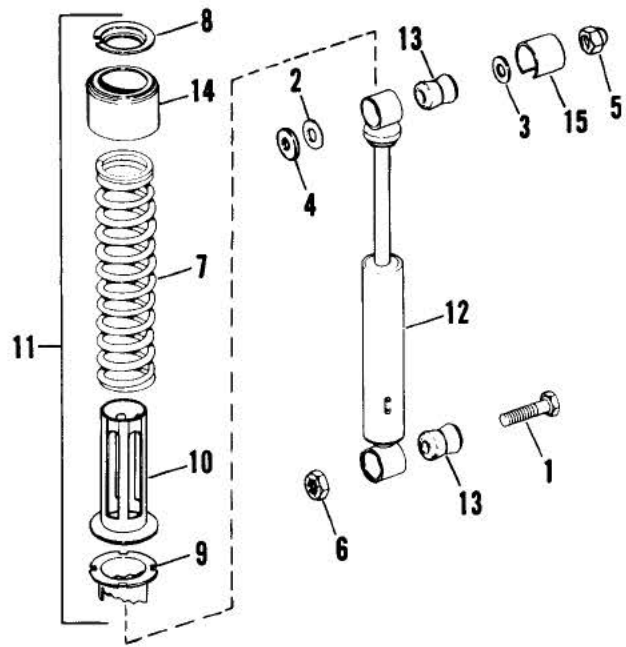

**SHOCK ABSORBERS**



**SHOCK ABSORBERS****RS52-6**

<b>RETAIL PRICE</b>	<b>INDEX NO.</b>	<b>PART NO.</b>	<b>NAME</b>	<b>USED ON</b>
	1	1614	BOLT (2) .....	85 to * — FXRS
	2	6530	WASHER (2) .....	85 to * — FXRS
	3	6701	WASHER (2) .....	85 to * — FXRS
	4	6962	WASHER (2) .....	85 to * — FXRS
	5	7680W	ACORN NUT (2) .....	85 to * — FXRS
	6	7812W	NUT (2) .....	85 to * — FXRS
	7	54468—79A	SPRING (2) .....	85 to * — FXRS
	8	54473—79	SPRING SEAT (2) .....	85 to * — FXRS
	9	54474—79	ADJUSTER, spring (2) .....	85 to * — FXRS
	10	54475—79	GUIDE, spring (2) .....	85 to * — FXRS
	11	54501—82	SHOCK ABSORBER, complete (2) .....	85 to * — FXRS
	12	54522—82	SHOCK ABSORBER, only (2) .....	85 to * — FXRS
	13	54523—82	BUSHING (4) .....	85 to * — FXRS
	14	54701—82	COVER, shock absorber (2) .....	85 to * — FXRS
	15	54705—81	COVER, stud (2) .....	85 to * — FXRS

RETAIL PRICE	INDEX NO.	PART NO.	NAME	USED ON
<b>CYLINDER, HEAD &amp; VALVES—V<sup>2</sup><sub>TM</sub></b>				
	16692—85A		HEAD, front cylinder (black wrinkle) .....	Late 86 — FXRC
	16696—85A		HEAD, rear cylinder (black wrinkle) .....	Late 86 — FXRC
<b>ROCKER ARMS, COVER &amp; PUSHROD—V<sup>2</sup><sub>TM</sub></b>				
	17528—84		ROCKER COVER, outer (chrome) (2) .....	Late 86 — FXRC
	17529—84A		SPACER, rocker cover (chrome) (2) .....	Late 86 — FXRC
	17530—84A		ROCKER COVER, inner (chrome) (2) .....	Late 86 — FXRC
	18622—85		TAPPET GUIDE, rear .....	N/A Late 86 — FXRC
	18623—85		TAPPET GUIDE, front .....	N/A Late 86 — FXRC
<b>CRANKCASE</b>				
	24493—85B		CRANKCASE SET (black wrinkle) .....	Late 86 — FXRC
	25268—84A		GEAR COVER (chrome) .....	Late 86 — FXRC
			Consists of besides gear cover:	
		2511	SCREW (2)	
		25275—82	COVER, breather	
		83162—51	OIL SEAL, bearing	
<b>STARTER SHAFT &amp; HOUSING</b>				
	31447—86		STARTER SHAFT HOUSING, with 9062 BEARING (black wrinkle) .....	Late 86 — FXRC
<b>TRANSMISSION</b>				
	16225—86		BRACKET, transmission to engine (black wrinkle) .....	Late 86 — FXRC
	34466—82		COVER, upper (chrome) .....	Late 86 — FXRC
	34700—86		HOUSING, transmission (black wrinkle) .....	Late 86 — FXRC
	35261—86		HOUSING, bearing (black wrinkle) .....	Late 86 — FXRC
	37075—84		FILL PLUG, with dipstick (polished) .....	Late 86 — FXRC
	37087—86		RELEASE LEVER (chrome) .....	Late 86 — FXRC
	37104—84		CLUTCH RELEASE COVER ASSEMBLY (chrome) .....	Late 86 — FXRC
<b>FRONT FORK</b>				
	14157—86		DECAL, "CUSTOM" (gold) .....	Late 86 — FXRC
<b>SEAT AND SISSYBAR</b>				
	52187—86		SEAT, rear .....	N/A Late 86 — FXRC
	52188—86		SEAT, front .....	N/A Late 86 — FXRC

RETAIL PRICE	INDEX NO.	PART NO.	NAME	USED ON
<b>FENDER &amp; LICENSE PLATE BRACKETS</b>				
	14153—86		TRIM, rear fender support — right (gold) .....	Late 86 — FXRC
	14154—86		TRIM, rear fender support — left (gold) .....	Late 86 — FXRC
	59546—86		SUPPORT, rear fender — right (chrome) .....	Late 86 — FXRC
	59547—86		SUPPORT, rear fender — left (chrome) .....	Late 86 — FXRC

**PRIMARY HOUSING**

	60612—86		PRIMARY HOUSING ASSEMBLY (black wrinkle) .....	Late 86 — FXRC
	60665—85B		COVER ASSEMBLY (chrome) .....	Late 86 — FXRC
	60667—85		INSPECTION COVER (chrome) .....	Late 86 — FXRC
	60668—84A		CLUTCH COVER (chrome) .....	Late 86 — FXRC

**FUEL TANK AND TRIM**

	14155—86		TRIM, console top (gold) .....	Late 86 — FXRC
	14156—86		TRIM, console bottom (gold) .....	Late 86 — FXRC

**INSTRUMENTS**

	67090—85		COVER, speedometer (chrome) .....	Late 86 — FXRC
	67092—85		COVER, tachometer (chrome) .....	Late 86 — FXRC
	67159—86		SPEEDOMETER & TACHOMETER, complete - m.p.h. ...	Late 86 — FXRC
	67160—86A		SPEEDOMETER & TACHOMETER, complete - k.p.h. N/A	Late 86 — FXRC
	67161—86		BRACKET, speedometer & tachometer (chrome) .....	Late 86 — FXRC

**STARTER SWITCHES**

	31475—77		COVER, solenoid (black) .....	Late 86 — FXRC
	31526—81B		STARTER SOLENOID (black wrinkle) .....	Late 86 — FXRC

**PAINTED PARTS**

	59037—86		FENDER, front (candy brandywine/black) .....	Late 86 — FXRC
	59038—86		FENDER, rear (candy brandywine/black) .....	Late 86 — FXRC
	61189—86		FUEL TANK (candy brandywine/black) .....	Late 86 — FXRC
	66389—86		SIDE COVER, left (black w/trim) .....	Late 86 — FXRC
	66390—86		SIDE COVER, right (black w/trim) .....	Late 86 — FXRC

## NUMERICAL INDEX

Part No.	Page	Part No.	Page	Part No.	Page	Part No.	Page	Part No.	Page
221	93	923	83		149	3427	9		83
	95		95	2682	27	3429	15	3825	62
222	55		97	2692 W	115	3430	9		75
239	15	924	95	2698	59	3444	49		77
256	125	933	83		62	3445	91	3826	77
275	12		123		113		105	3839 W	75
332	33	1203	89	2711	71	3461	9	3862 B	44
335	33	1309	97	2712	21	3473	55	3953 W	103
336	33	1601	12	2731 W	23	3481	5		105
358	9		23		111	3485	25	3960 W	71
	12	1607	83		117	3486	75	3974 HW	21
375	33	1611	83	2733	71	3487	71	3987	19
515	55	1614	79	2757 W	71	3491	43		69
520 W	72		151		72	3494	17		72
601	29	1615	71	2774	91	3496	57		97
604	72	1651	83		133	3498	81	3991	71
609	33	1783	44	2779	83	3500	5		97
614	125		47		87	3501	5	3993	29
634	33	2002	62	2784	83	3503	75	3996	71
653	12	2216 W	21	2790 A	133		77	3997	5
706 A	101	2330	49	2796 W	131	3504	9	4011	69
708 A	62	2331	49	2804 W	133	3506	9	4014 W	59
717	62	2337 W	133	2806	133	3512	9		62
718	93	2339	117	2818	25		33		75
720	9	2420	91		95	3513	9		77
721	25		133		103		33		103
	29	2501	55		105	3517	51	4015	43
722	33	2508	81	2823	65		145		49
728	72		83		67	3519	9		143
735	72		127		69	3524	87	4016	29
	133	2511	12		149	3542	62	4017	17
738	19		138	2824 W	91	3651	99		19
739	95		152	2851	75	3652	99		27
	139	2538	72		83	3655	53	4023	93
812	23		101	2871 W	17		147	4024	93
813	72	2551 W	101		33	3766	111	4026	93
853	81	2579	49		89	3767 B	71	4036	103
	107		143		93		115		105
854	65	2592	117		95		125	4067	97
855	51		129	2872 W	15	3770	5	4068	95
	145	2607	71		129	3771	59	4069	113
856	29		91	2879 W	33		62	4070	113
857	33		101	2881 W	41	3782	59	4081	79
	44		133	2882 W	83	3784	29	4086	95
	47	2608	75	2887 W	25	3785	91	4100 HW	77
864	19	2611 B	23		55	3787	17		97
867	81	2614	44		91		19	4319	9
871	81		47		103		21		103
884	5	2648	83		133		33	4337 W	105
907	97	2653	21	2889	9		43	4371 W	65
919	71	2661 W	49	2903	87		87		67
	97		65	3210	19		129		72
920	75		67		33		133		83
	77	2662 W	65		91		136		149
922	83		67	3233	117	3802 W	55	4391	21

## NUMERICAL INDEX

Part No.	Page	Part No.	Page	Part No.	Page	Part No.	Page	Part No.	Page
	113		63	6229 W	83		103		147
4401 W	44	5743	81		133		105	7036	15
4411	65		111	6242 W	12		125		27
	67	5887	12		23		151		33
	69		103	6257 W	72	6702	19		41
4412	113		105	6265	89		55		43
	133	5926 B	59	6314 W	29		59		63
4702	62		63	6316 HW	103		63		71
4716 W	9	6003	37		105		65		77
	72	6007	33	6317	55		67		87
	77	6016	5		77		71		91
4717	33		9	6324 W	95		77		115
4718	12		17	6333	83		91		125
	23		19		133		97	7038	9
	33		25	6336 B	49		103		44
	95		27	6379 W	3		105		69
4720 W	9		29		75		117		73
4721	3		33	6381	29		133		75
	9		93	6398	59		149		75
	75		95		63	6703	27		77
4724	69	6019	3	6400 HB	3		44		79
	75		9		9		47		83
	149		33		44		49		125
4726	59		51		47		63	7039	73
	139		72	6409	29		71		77
4729	72		83	6410	71		73	7041	25
4740	93		105		91		83		27
	95		145		133		87		33
4800	33	6028	107	6416	57		91		39
4809	81	6053	83		79		101		59
4810	12	6055	87	6469 HW	33		129		63
4811	72		133	6497 HW	29		133		65
	93	6099	5	6506	7		136		67
4812	49		12	6516 HW	9	6716	23		69
	63		23		55		27		73
	93		33		59		55		75
	143		41		63		97		77
4813	12		43		139	6717	87		89
4814	33		49	6530	79		133		91
	93		72		151	6718	75		103
4815	33		93	6645	71	6730	55		105
4816	81		95	6653	53	6736	5		117
5207	83		143		147		15		129
5210	83	6107 B	59	6655	59		29		149
5403 B	91		63		63	6737	5	7042	81
5411	103	6109	19	6701	3	6759	97		83
5444	44		21		27	6762 B	5		113
	47		71		59	6771	17	7068	75
5713	91		91		63	6774	133		75
5714	117		97		69	6962	79		77
5724	71	6182 W	83		72		151		89
5733	129	6192	129		75	6970	87		105
5736	81	6194	12		77	7022	53	7069	12
	107		23		79		59		27
5738	57	6220 W	55		83		63		63

## NUMERICAL INDEX

Part No.	Page	Part No.	Page	Part No.	Page	Part No.	Page	Part No.	Page
	97	7545	107	7744	19	7851 W	43	9123	9
	115	7561	59		29	7880	75	9124	9
	129		139		55		89	9125	9
7112	133	7608	43		81	7986	59	9126	9
7118	23		97		117		63	9127	9
	117	7609 W	83	7748 W	33	8098	117	9128	9
	123	7610	57		39	8099	73	9129	9
7124	21	7620 W	27		65		101	9130	9
	73		63		67	8102	19	9131	9
	133		129		73		91	9132	9
7127	21	7626 W	83		103	8107	111	9133	9
	33	7628	75		129	8151	83	9134	9
	55	7634	12		149	8227	39	9135	95
	73		23	7752	133	8483	83	9181	7
	95		129	7753	9	8501	73	9182	7
	113	7638	19		21	8502	87	9183	7
7129	123		23		103	8508	133	9184	7
7130 W	91		97		105	8519	89	9185	7
	113		125	7763 W	129		91	9186	7
	133		129	7768 W	81		129	9217	11
7143	43	7667	125	7775	3	8533	133	9218	11
7145 W	75	7676	63	7776 W	3	8625	136	9219	11
	125	7680 W	79		75	8672	125	9221 A	11
7220	23		151		133		129	9222 A	11
	27	7682	77	7778	3	8687	83	9223 A	11
	49	7686	23		9	8699	12	9224 A	11
	65		71		44		23	9225 A	11
	67		73		47	8858	77	9441 A	7
	89		83		59	8873	15	9443 A	7
	125		87		75	8876 A	37	9444 A	7
	129		91		139	8904	37	9445 A	7
	149		133	7780	9	8975	93	9446 A	7
7229 W	97		136		103	8977	33	9450 A	7
	129	7688	21		105	8978	33	9540 A	39
7230	27		27	7782	9	8980	93	9851	55
	83		83	7783	9	8996	33		77
	115		91		79	8998	33	9856	97
7232	71	7689 W	55		125	9028	9	9857	23
	73		91	7800 W	3	9052	53		69
	97		131		75		59		97
	103	7725	73	7812 W	79		63		107
7402	93	7736	117		151		138		109
7415 A	133	7737 W	133	7813	53		139		117
7419	133	7739	75		147		147		119
7501	113		81	7825	55	9058	12	9858	119
	115		83		73	9062	25	9859	83
7507	77		97	7827 W	9	9063	25	9862	21
	97		133		59		93		119
7515	29	7740	19	7828	73		95	9863	119
7520	133		55	7837 W	77		139	9866	119
7531	91		81	7844	81	9114	29	9875	119
	103	7742	63	7845	75	9115	29		127
	105		77		77	9120	9	9879	119
	133		129		105	9121	9	9885	23
7544	69	7743	97	7848 W	41	9122	9	9894	97

## NUMERICAL INDEX

Part No.	Page	Part No.	Page	Part No.	Page	Part No.	Page	Part No.	Page
9898	83		93	11449	113	16216-83D	3	17925-83	5
	119		101	11469	73	16219-79A	3	17926-83	5
	127	10081	49	11726	63		11	17927-83	5
9900	23		107	12013 A	37	16225-86	152	17928-83	5
	119	10084	33	12014	39	16302-81	11	17929-83	5
9905	119		101	12026 B	11	16478-83	3	17930-83	5
9931	83	10086	101	12043	33	16478-85A	3	17931-83	5
9937	119	11002	12	12044 A	33	16480-83	3	17932-83	5
9952	83		15	12045	29	16480-85A	3	17935-79B	5
	89	11007	11	12050	33	16482-83	3	17938-83	5
	129	11013	19	12051	33	16482-85	3	17945-36B	5
9955	103	11016	29		95	16510-83	3	17947-36	5
	105	11019	33	12052	95	16573-83	3	17950-66	5
9988	81		39	14004-82	99	16690-85A	3	18001-83A	3
	97	11020	33	14005-82	99	16691-85A	3	18010-83	3
9991 A	17	11039	25	14006-82	99	16692-85A	152	18020-83	3
10006	19	11041	25	14050-86	65	16696-85A	152	18074-83A	3
	23	11057	33	14052-83	79	16715-83	3	18076-83	3
	69	11067	37	14052-85	69	16773-85	3	18082-83	3
	83	11083	29		79	16774-86A	3	18087-83	3
	113	11096	37	14053-83	133	16778-84	5	18130-83C	3
	115		39	14055-84	99	16779-84A	5	18131-83C	3
	119		41	14056-84	99	16830-29A	3	18133-83A	3
	136	11105	12	14067-84	99	16831-83	3	18201-83	3
10007	127		15	14068-84	99	16837-83	3	18202-83	3
10014	17	11115	63	14072-84	99		11	18219-83A	3
	33	11117	29	14072-86	99	16837-85A	3	18222-83	3
	97	11132	5	14073-84	99		11	18229-83	3
10031	49		69	14073-86	99	17033-83A	3	18523-86	5
10033	115		101	14077-86	99		5	18540-83A	5
10038	55	11143	43	14078-86	99	17035-83B	3	18542-83	5
10039	101		49	14101-84	101		5	18622-85	152
	119		143	14105-85	99	17355-84	5	18623-85	152
	131	11145	5	14105-86	99	17356-84	5	18633-48C	5
10044	27	11147	93	14106-85	99	17358-84	5	18634-48B	5
10046	12		95	14106-86	99	17360-83	5	21920-83	7
	23	11148	29	14114-86	83	17375-83	5	21921-83	7
10048	103	11150	29	14116-86	129	17428-57	5	21922-83	7
10049	101	11155	81	14118-86	87	17503-84	5	21923-83	7
10053	49		127	14119-86	87	17510-84	5	21924-83	7
10054	67	11157	5	14122-86	99	17521-84A	5	21940-83	7
	69	11160	11	14133-86	83	17528-84	137	21941-83	7
10059	43	11161	33	14134-86	83		138	21942-83	7
10065	21	11162	37	14135-86	99		152	21943-83	7
	113	11165	33	14136-86	99	17529-84A	137	21944-83	7
	115	11170	69	14153-86	153		138	22589-83	7
	119	11171	69	14154-86	153		152	22764-83	7
	127	11218	7	14155-86	153	17530-84A	137	23906-78G	7
10067	131	11404	73	14156-86	153		138	23909-80	7
10070	33	11411	59	14157-86	152		152	23961-80A	7
	101		63	16207-79B	11	17611-83	5	23969-83	7
10080	11	11428	63	16208-83	11	17921-83	5	23985-18	75
	33	11440	129		33	17922-83	5		77
	44	11442	113	16208-85	11	17923-83	5		105
	69	11448	89		33	17924-83	5	23985-54	7



## NUMERICAL INDEX

Part No.	Page	Part No.	Page	Part No.	Page	Part No.	Page	Part No.	Page
	12	24650-81	11	25555-36	13	27048-84	136	29116-83	17
24002-70	11	24651-58	11	25555-84	13	27060-55	125		19
24006-83	7	24652-58	11	25556-79	13	27065-85	136	29121-84	136
24016-80	7	24653-58	11	25557-79	13	27068-85	136	29126-83	19
24017-80	7	24654-58	11	25558-79	13	27073-84A	136	29134-83A	19
24023-54	12	24655-58	11	25559-79	13	27074-84	136	29134-86	19
24032-70	11	24692-58	11	25581-70	13	27075-84	136	29141-85	136
	45	24703-54B	13	25582-73	13	27079-84	17	29145-84	19
	47	24922-86	19	26052-86	13	27130-81	17	29145-86	19
24033-70	11	24981-70	13	26058-84	15	27136-81	17	29165-83A	19
	45	24982-70	13	26190-73	15	27137-81	17	29166-83	19
	47	25225-70B	13	26207-83	15	27139-81	17	29166-86	141
24034-70	11	25258-80B	13	26227-58	15	27143-81	17	29168-83A	19
	45	25268-84A	137	26242-84	15	27144-83	17	29171-85	19
	47		138	26262-80	15	27144-86A	17	29172-85	19
24035-70	11		152	26263-80	13	27145-81	17	29174-85	19
	45	25275-82	13		15	27301-86	17	29202-84	19
	47		138	26273-80B	15	27302-84	17	29210-86	19
24036-70	11		152	26276-80A	15	27304-76	17	29225-79	19
	45	25313-77C	13	26285-82A	15	27307-76	17	29228-80	19
	47	25320-82	13	26315-68A	15	27308-76	17	29242-83	17
24037-70	11	25321-82	13	26317-68A	15	27309-76	17	29250-78A	17
	45	25322-82	13	26326-62A	15	27311-76	17	29252-86B	19
	47	25323-82	13	26327-68	15	27324-83	17	29259-83A	19
24040-78	13	25325-82	13	26328-74	15	27325-83	17	29259-86	19
24041-78	13	25326-82	13	26338-68	15	27325-86	17	29264-86	136
24042-78	13	25327-82	13		33	27327-83	17	29269-83	19
24043-78	13	25328-82	13	26345-73	13	27329-83	17	29283-86	19
24044-78	13	25402-79A	63	26346-70	13	27330-83	17	29290-83	11
24045-78	13	25403-82A	63		15	27333-76	17	29290-86	11
24046-78	13	25404-80	63	26348-15	7	27335-76	17		19
24281-83	7	25405-82	11		13	27360-76	17	29293-86	19
24334-36	7	25410-79A	63		15	27361-76	17	29954-71	21
24335-36	7	25411-79	63	26348-36	15	27362-76	17	29957-81B	21
24345-36A	7	25412-79	63	26349-73A	13	27366-76	17	29960-85	21
24356-36A	7	25413-79	63	26349-84	13	27367-76	17	29961-85	21
24366-71	7	25414-70A	93	26350-85	33	27368-76	17	29965-81A	21
24367-71	7		95	26352-85	33	27369-76	17	29988-73	21
24385-40B	7	25414-82	63	26400-82	15	27370-83	17	30013-71	113
24387-40B	7	25416-70	93	26432-76A	3	27371-76	17	31340-80	25
24388-40B	7	25416-84	93	26496-75	33	27385-76	17	31433-84A	93
24389-40B	7		95	26557-83	3	27886-78	17		95
24390-40B	7	25536-84	13		17	27887-78	17	31435-65B	125
24391-40B	7	25537-84	13	26561-84	13	27888-78	17	31438-65A	125
24493-85B	152	25538-84	13		129	27891-80	17	31439-65A	125
24530-79	13	25539-84	13	26570-84	17	27898-78	17	31439-84	125
24546-83C	11	25544-84	13	27008-83A	17	28807-85	136	31440-65	125
24553-83	11	25545-84	13	27012-83A	17	28807-86	136	31441-65A	125
24582-83A	13	25546-84	13	27018-85	136	28813-86	136	31443-65A	25
24599-58A	11	25550-36	13	27019-83	17	28815-86	136	31444-65A	125
24600-58A	11	25550-57	13	27023-71	17	29058-77	17	31447-86	152
24601-58A	11	25551-36	13	27029-83D	17		19	31475-77	153
24641-36	13	25552-36	13	27029-86B	17		136	31479-83	27
24645-81	11	25553-36	13	27042-84	136	29068-86	19	31485-65	25
24649-81	11	25554-36	13	27047-84	136	29110-83	19	31489-79B	125



## NUMERICAL INDEX

Part No.	Page	Part No.	Page	Part No.	Page	Part No.	Page	Part No.	Page
31491-79	25	33120-85	25	34621-84	31	37077-68	39	37574-44	39
31493-67	25	33121-79	25	34632-84	31	37083-80A	35	37576-41	39
31495-79	25	33163-65B	39	34700-86	152		39	37581-47	39
31497-83	25	33189-63	75	34726-84	35	37084-79	35	37583-41	39
31502-65	25	33205-80	29	34730-81	35		39	37585-41	39
31503-65	25	33206-80	29	34730-84	35	37087-86	152	37702-70A	39
31506-79B	125	33207-80	29	34730-85	35	37088-79	37		45
	129	33208-80	29	34730-86A	35		39	37702-84	41
31524-80	27	33209-80	29	34901-79B	93	37088-84	37		45
31526-81B	153	33210-80	29	34901-85	95		41	37707-84	41
31564-83	27	33211-80	29	34902-79A	93	37088-85	37		45
31570-73	27	33212-80	29	34903-79	93		41	37800-84	41
31572-86	25	33318-85	95	34904-79	35	37089-79	37	37801-84	41
31575-73	27	33320-79A	29	34904-86	35		39	37816-41	39
31576-73	27	33326-79	29	34906-79A	93	37089-84	37	37850-68	39
31577-73	27	33332-79	29	34906-85	95		41	37871-41	39
31578-73	27	33334-79	33	35025-79	37	37090-79	37	37871-84	41
31579-73	27		45	35026-79A	37		39	37901-84	41
31580-73	27	33334-85	33	35027-79A	37	37090-84	37	37902-84A	41
31581-73	27	33336-83	35	35028-79	37		41	37903-84	41
31582-73	27		45	35029-79	37	37091-80	35	37904-84	41
31583-73	27	33339-86	35	35029-84	37	37096-83	35	37905-84	41
31584-73	27		45	35029-85A	37		39	37906-84	41
31585-73	27	33347-86	33	35042-79	37	37096-85	35	37907-84	41
31586-73	27		45	35042-84	37	37098-83	35	37930-68A	39
31589-80	87	33715-80A	29	35042-85	37		43	37931-84	41
31609-80	23	33715-85	29	35064-79	37	37098-85	35	37975-81	39
31614-83	23	33728-82A	29	35068-79	31		43	37975-84	41
31625-82	23	33900-59	35	35074-79A	35	37100-84	35	38599-83A	43
32311-83	23		125	35076-79	35	37101-84	35	38608-82B	43
32342-58	23		129	35078-79	35	37102-84	35	38712-68	43
32400-80A	23	34082-79	29	35211-36	35	37104-84	137		55
32402-83	23	34083-79	29		45		138	39951-81	45
32405-88	23	34084-80	29	35250-79A	35		152	39974-84	45
32504-80	13	34084-86	29	35261-86	152	37312-75	37	39976-65B	45
	23	34085-79A	29	35622-79A	37		39		47
32524-83	13	34086-79	29	35625-79A	37		41	39990-65	45
	23	34087-79	29	35626-79A	37	37313-80	37		47
32591-80	13	34088-79	29	35629-79	37		39	39992-65C	45
	23	34089-79	29	35632-79	37		41		47
	23	34091-85	37	35652-79A	35	37357-41	39	39993-65	45
32604-78	23	34191-79C	31	35850-84	11	37357-84	41		47
32606-82	13	34193-79C	31		45	37361-41	39	39996-65	45
	23	34195-79C	31		47	37496-65	39		47
33017-85A	33	34462-79A	35	35851-84	11	37496-84	41	39998-65	45
33020-86A	33	34466-82	137		45	37503-41	39		47
33042-80	93		138		47	37523-15A	39	40001-85	47
33043-80	33		152	35852-84	11		41	40011-84	45
	125	34561-84	31		45	37523-85	37	40016-84	45
	129	34596-86	31		47		41	40020-84	45
33048-72	75	34597-86	31	36801-79	35	37549-41	39	40026-77	45
33114-79	33	34599-81	31	37071-79	35	37550-41B	39	40028-15E	45
33115-79	33	34611-65	31	37072-79	35	37550-84	41	40029-15E	45
33119-79A	29	34619-85	31	37075-84	138	37566-58	39	40037-79	45
33120-79	25	34621-82	31		152	37567-41A	39		47

## NUMERICAL INDEX

Part No.	Page	Part No.	Page	Part No.	Page	Part No.	Page	Part No.	Page
40052-65	45	41191-74	35	43287-83	63		145	45012-82	49
40053-65	45		63	43290-82	63	44020-83	51	45013-85	49
40055-39	45	41470-86	45	43291-82	63		145		143
	47		59	43292-82	63	44021-83	51	45015-83	49
40091-15	45	41521-83	45	43293-82	63		145	45016-82	49
40100-85	47		63	43294-82	63	44022-83	51		143
40210-85A	35	41570-77	73	43310-83	63		145	45017-82A	43
	47	41591-81	59	43312-84	53	44023-83	51	45019-85	49
40221-85A	47		63		137		145	45021-86	43
	59	41591-84	59		138	44046-84	51	45031-82	49
	63	41665-82	57	43338-83	53		145		143
40266-85	45	41731-82	49		147	44047-83	51	45032-82	43
	47		143	43358-83A	53		145		49
40267-85	45	41739-84	49		138	44048-83	51		143
	47	41747-82A	49		147		145	45036-82	43
40269-85	45		143	43359-84	53	44050-82A	57	45039-68	43
	47	41791-79A	59	43567-79	59	44053-83A	51	45042-82	49
40275-83	45		63		63		145		143
40299-83	45	41800-81A	55		139	44054-83	51	45044-82	43
	47	41804-84A	55	43578-35	11		145		49
40375-70	45	41814-76A	53	43601-78A	59	44055-83	57		143
40384-83A	45	42240-85	55		139	44059-83	51	45051-82	49
40392-70	45	42256-85	55	43602-78A	59		145		143
	47	42269-30	55		139	44060-83	51	45057-82	49
40918-82	55	42334-82	75	43603-78A	59		145	45063-82A	49
40920-82	55		77		139	44061-83	51	45065-83	49
40922-79	55	42376-77A	55	43604-78	59		145	45067-83	49
40932-81	59	42382-82A	55		63	44062-83	51	45068-83	49
	63	42416-83	55	43605-78	59		145	45072-87	49
40951-82	59	42437-81	55		63	44063-83	51	45092-66A	17
	139	42446-82A	55	43606-78	59		145		107
40952-82A	59	42448-82A	55		63	44065-83	51		109
	139	42455-80	55	43619-84	53		145	45095-85	11
40954-83	45	42460-80A	55		138	44126-82	55	45121-84	49
	59	42523-82	55	43623-78	53	44136-84A	53	45121-88	49
40956-82	55	42524-82	55		138		147	45128-84	49
40975-86	59	42534-82	55		147	44146-82	57	45128-85	49
40976-86	59	42535-85A	55	43624-78	53	44197-77	51	45128-86	49
40983-83A	59	42538-85	55		138		57	45136-85	143
40983-86	59	43001-79	53		147		145	45382-83	65
41015-82A	59		138	43625-78	53	44199-82	57		67
	63	43024-73B	53		138	44200-82	57		149
41015-86	59		137		147	44201-82	57	45385-83	67
	63		138	43626-84	53	44205-82	57		149
41057-83	137	43025-73B	53	43650-82	63	44207-82	57	45386-83	65
41087-83	63		137	43654-86A	59	44208-82	57		67
41110-79	59		138		63	44209-82	57		149
	63	43032-40B	59		139	44211-82	57	45387-83	65
41112-79	73		139	43667-82	63	44212-82	57		67
41123-79	53	43085-81	59	43868-72	11	45004-85	49		149
	59		139		35		143	45388-83	67
	63	43150-83	53		93	45005-85	49	45389-83	67
	69		147	43883-84	53		143		69
	79	43157-83A	59		147	45006-87	49	45389-86	67
	147		63	44019-83	51		143	45392-83	67

## NUMERICAL INDEX

Part No.	Page	Part No.	Page	Part No.	Page	Part No.	Page	Part No.	Page
	149		67	46458-86	69	49017-82A	73	52107-86	71
45392-86	67		149	46459-86	69	49126-77A	75		97
	149	45791-84A	67	46461-86	69	49126-77B	75	52108-86	71
45398-84A	149	45793-84	67	46503-86	69	49127-77	75	52111-83	71
45399-84A	149	45793-85A	67	47005-82D	73	50009-82	73	52111-85A	71
45403-84	65	45830-48	11	47159-79A	11	50011-30A	73	52123-83	71
	67		15	47247-83	77	50016-82	73	52132-85	139
	149	45903-84A	65	47311-77	117	50031-84A	73	52136-85	139
45404-75	65	45904-84A	65	47505-86	73	50069-82A	73	52138-82A	71
	67	45906-84	65	47510-80	73	50069-84	73	52139-82	71
	149		67	47511-80	73		141	52141-82	71
45405-75A	65	45908-80	65	47512-82	73	50069-86	73	52142-82A	71
	67		149	47513-80	73		141	52143-85	139
	149	45909-83	67	47514-80	73	50531-81	75	52187-86	152
45406-75	69		149	47515-80A	73		77	52188-86	152
45407-83	65	45912-84	65	47515-82A	73	50604-83	77	52202-86	71
45407-86	65		67	47515-86	73	50606-83	77	52213-82	71
45408-84	65		149	47519-83A	53	50606-86	77	52355-82	71
45410-84	65	45913-84	67		61	50613-86	77	52440-84	137
	67		149		63	50614-66	77	52441-84	137
	149	45914-84	65		138	50619-74A	77	52700-81	75
45412-75	65	45982-73	65		139	50620-74	77	52713-86	77
	67		67		147	50632-85	77	52714-86	77
	149		69	47538-79	73	50634-85	77	52715-86	77
45413-84	65		149	47556-81	73	50635-82	77	52717-86	77
	67	45993-73	65	47564-82	73	50636-81A	75	52739-83	71
	149		149	47564-86	73	50639-81	75	52757-82	71
45416-84	65	45993-86	65	47692-84	67	50643-82	75	52765-85	71
	67		149	47693-84	65	50646-82	75	52766-85	71
	149	45994-84	65		149	50647-82	75	52771-82	71
45423-85	139		67	47694-84	65	50660-85	77	52789-86	71
45429-84	65		149	47820-81A	73	50662-85	77	52790-86	71
	149	45997-73	65	47825-81	73	50664-85	77	52798-87	71
45429-86	65		67	47826-81	73	50900-72	75	53125-86	87
45583-83	49		69	47829-83	73	50912-72	75	53126-86	87
	69		149	47830-86	67	50921-83	75	53415-83	87
45585-83	69	45998-73	65	48036-84B	73	50932-86	77	53427-80	87
45587-83A	69		67	48039-85	73	50933-86	77	53433-80	83
45589-84	67		149	48140-84	65	50939-52	75	53439-79	107
45621-83	69	46020-84	65		67	50940-52	75		109
45621-83A	69		67	48152-82	87	50946-52	75		111
45718-71	65		149		133	50960-86	77	53443-84	87
	67	46450-83A	69	48300-60	65		105	53510-80	87
	149	46450-85	69		67	50961-86	77	53564-82	87
45736-78B	65	46450-86	69		149		105	53580-82	87
	67	46451-83	69	48315-60	65	50962-86	77		133
	149	46451-85	69		67		105	53582-82	87
45743-84	65	46452-83	69		73	50973-65	75		133
45746-84	65	46452-85	69		149	51651-79	71	53589-86	87
45751-71A	65	46454-83	69	48361-80	65	51652-83	71		133
	149	46455-84	69		67	52005-85A	71	53590-84	133
45782-72A	65	46455-85	69		149	52020-82	71	53615-85	87
	67	46456-84	69	48365-48A	65	52041-82	71	53616-85	87
	149	46457-85	69		67	52103-31	61	53617-85	87
45790-80	65	46457-86	69		149	52106-86	71	54310-83	79

## NUMERICAL INDEX

Part No.	Page	Part No.	Page	Part No.	Page	Part No.	Page	Part No.	Page
54311-83	79	56323-81C	81	59256-84	113	61060-82A	97	63585-82	93
54314-83	79	56324-81C	81	59263-79	91	61079-82	97	63805-80A	35
54315-83	79	56336-83	81	59267-83	71	61082-79	31	63858-49	5
54316-83A	69	56337-83	81	59270-84	115	61085-84	137	64511-63	129
	79	56394-74	81	59271-68	117	61090-82	97	65276-62	103
54321-85	53		127	59500-81	91	61109-85	97		105
	61	56396-74A	81	59500-84	91	61112-82	97	65301-86	105
	139		127	59501-81	91	61115-82	97	65302-82	103
54323-85	69	56397-74C	81	59501-84	91	61117-86	97		105
54324-85	79		127	59502-84	91	61135-57	61	65306-83	103
54468-79A	151	56402-83A	81	59503-84	91	61189-86	153	65310-83	103
54473-79	79		127	59504-84	91	61311-82	97	65310-85	103
	151	56508-76	81	59505-84	91	61321-80	97	65324-83	103
54474-79	79	57807-86	83	59514-85	139	61322-80A	97		105
	151	57808-86	83	59516-85	139	61335-83	97	65325-83	103
54475-79	79	57809-86	83	59546-86	153	61411-82	97		105
	151	58014-83	83	59547-86	153	61413-86	97	65328-83	103
54477-84	79	58040-83	83	59573-83	91	62044-82	97		105
54491-83	79	58042-86	83	59605-84	137	62150-85	136	65342-86	105
54491-85	79	58147-83	83	59634-81A	91	62161-75	97	65354-86	105
54492-85	79	58147-86	83	59983-75	91	62166-81	97	65359-86	105
54493-85	79	58150-83	83	59984-73	91	62172-75	97	65369-86	105
54494-85	79	58190-83	83	59986-75	91	62375-57	35	65410-83	103
54495-85	79	58190-86	83	59988-72	91	62406-81	101	65431-86	105
54496-85	79	58212-86	83	60001-55	91	62406-86	101	65441-86	105
54501-82	151	58218-83	85	60031-61	135	62414-86	101	65481-83A	103
54502-84	79	58218-86	85	60299-85	61	62460-86	101	65482-83	103
54518-84	79	58219-86	85		63	62540-83	101	65551-86	103
54522-82	151	58220-83	85	60397-85A	73	62637-84	101	65594-86	105
54523-82	79	58220-86	85	60604-80	93	63500-68	19	65656-82A	103
	151	58222-83	85	60605-79B	93		45	65656-83	103
54701-82	79	58223-86	83	60605-85	95		55	65657-82A	103
	151	58224-83	85	60607-81A	61		69	65657-83	103
54705-81	79	58227-83A	85	60612-86	153		93	65668-83	103
	151	58265-86	85	60629-82	31		101	65668-86	103
56073-83	81	58454-86	85		93	63501-68	35	65669-83	103
	89	58498-86	85	60640-86	61		97	65669-86	103
	127	58499-86	85	60642-82	93	63504-83	101	65670-82B	103
56081-82	81	58661-86	123	60642-84	93	63505-84	97		105
56087-83	81	58662-86	123	60642-85	95	63509-86	19	65674-82	103
56087-86	81	58703-86	85	60657-84	93	63533-41	11	65685-86	105
56105-84	81	58706-86	85	60662-84	93		15	65702-86	103
56111-85	139	58708-86	85	60662-85A	95		35	65723-85	105
56112-85	139	58709-86	123	60662-86A	95		93	65732-86	103
56115-77	139	58722-84	85	60664-85B	95	63551-82	55	65738-84	103
56115-79A	81	58723-84	85	60665-84	137	63557-84	101	65739-84	103
56116-82	81	58998-83	91	60665-85B	139	63558-84	35	65746-86	105
56117-82	81	59007-84	91	60665-86B	153	63558-85	15	65747-86	103
56144-86	81	59010-84	137	60667-84	137		35	65759-86	105
56146-86	81	59037-86	153	60667-85	139	63559-84	101	65779-86	105
56153-73	81	59038-86	153	60668-84A	137	63561-84	55	65780-82	103
56158-73	81	59111-74	91		139	63563-84	101	65781-82	103
56159-73	81	59254-72	65		153	63563-85	101	65782-82	103
56206-81A	81		67	60678-85	95	63580-66A	93	65786-86	105
56220-81B	81		149	61044-82B	97		101	65789-86	105



## NUMERICAL INDEX

Part No.	Page	Part No.	Page	Part No.	Page	Part No.	Page	Part No.	Page
65794-86	105	67105-83	107	67809-75	89	68543-64B	85	70022-83	119
65798-86	105	67106-83	107	67815-59A	89		113	70027-83	119
65799-86	105	67107-83	107	67830-59	73		115	70034-82	119
65801-86	105	67108-83	107		89	68549-84	113	70035-82	119
65991-82A	131	67112-83	107	67834-83	89	68550-83	85	70036-82	119
66000-80	131	67117-85	107	67839-74	89		113	70043-81	119
66042-79A	101	67122-85	109	67851-86	109		115	70047-82	127
	131	67127-84A	53	67862-86	109	68554-82	115	70049-83	119
66103-74A	131		107	67864-86	109	68557-70A	115	70050-83	119
66104-84	131		109	68008-73A	113	68562-84	113	70062-85	119
66183-82	131		111		115		115	70069-65B	119
66188-82A	131		147	68025-73	113	68571-63A	115	70082-82	127
66342-84	73	67152-86	111		115	68572-64A	113	70083-82	119
66343-84	73	67153-86	111	68026-73	113		115	70097-75	119
66349-84	73	67154-86	111		115	68574-83	107	70100-79A	119
66350-84	73	67155-86	111	68034-77	113		111	70146-84	119
66389-86	153	67156-86	111		115	68574-86	107	70147-86	85
66390-86	153	67157-86	111	68089-80	85	68586-63A	115	70149-86	123
67002-84	107	67158-86	111	68092-80	85	68588-86	111	70150-86	85
67002-85	107	67159-86	153	68123-73	113	68597-86	107	70155-84	119
67020-85	109	67160-86A	153		115	68608-83	107	70156-84	119
67021-85A	109	67161-86	153	68165-64	85		109	70180-86	127
67029-86	111	67200-86	109		113		111	70181-86	127
67034-83	107	67201-86	109		115	68643-83B	115	70186-82	35
67036-83	107	67202-86	109	68402-86	115	69006-82	117		73
67036-86	107	67239-83	49	68404-86	113	69006-84	117		119
67037-83	107	67636-86	85	68406-86B	113	69007-82C	117	70187-82	23
67037-85A	107	67693-83	85	68407-86	113	69007-84	117	70191-73A	65
67039-83	107	67694-83	85	68435-84	113	69149-65	117		67
67041-83A	107	67696-81	88	68440-86	115	69512-83	85		119
67042-83	107	67697-81	88	68451-86	115	69515-83	85		149
67042-85	107	67698-81A	89	68452-86	113	69516-83	85	70218-86A	127
67046-83	107	67700-83	85		115	69517-83	85	70218-87	127
67046-85	107	67701-83A	88	68455-86	113	69540-78	97	70219-86A	127
67046-86	107	67703-83	85	68457-86	113	69545-82A	119	70246-85	119
67047-83	107	67709-83	85	68461-83	107	69545-84	119	70287-81	119
67047-86A	107	67710-83	85	68464-86	107	69545-86	119	70288-81	119
67048-83A	107	67712-83	88	68465-83	85	69548-86	111	70345-84	119
	141	67714-83	85	68465-86	111		119	70422-82	121
67052-78B	107		88	68468-86	107	69551-85	119	70466-86	123
67054-83A	111	67715-86	85	68477-73	113	69554-86	119	70504-81	81
67054-83B	107	67716-60A	88	68480-73	113	69606-82	117	70551-69	121
67056-84	107	67718-60A	88	68481-73	113	69617-82	97	70552-69	121
67067-76	131	67719-63	89	68482-73	113	69618-82A	97	70553-69	121
67078-85A	109	67724-71	88	68483-73	113	69619-82	97	70554-69	121
67085-83	107	67725-63	89	68486-82A	113	69620-86	119	70555-69	121
67086-85	109	67726-71	88	68487-82	113	70003-83	119	70556-71	121
67090-85	153	67732-71	88	68489-83	107	70004-83	119	70558-71	121
67092-85	153	67743-84	89		111	70005-70	119	70559-71	121
67094-85	109	67744-75	89	68489-86	107	70007-83	119	70576-68	115
	111	67755-81	88	68504-83	113	70012-83	119		121
67095-85	109	67778-60	88	68520-63	115	70013-83	119	70579-65	121
67097-86	111	67780-60	88	68521-63A	115	70014-83	119	70719-87	127
67103-83	107	67805-86	89	68531-78	113	70019-86	119	70970-82C	129
67104-83	107	67807-86	89	68536-86	109	70021-83	107	70973-82A	129

## NUMERICAL INDEX

Part No.	Page	Part No.	Page	Part No.	Page	Part No.	Page	Part No.	Page
70974-84	129	72041-71	115	76302-86	123		139		
70979-86	129		121	77008-86A	123	95582-47	53		
71099-74	97	72043-71	97	77025-86	123		61		
71251-86	111		109	77027-86	123		138		
71252-86	111		121	77028-86	123		139		
71424-83	129		127	77029-86	123	95594-84	53		
71425-77	129	72044-71	121	77030-86	123		61		
71451-78	129	72046-79	121	83162-51	13		63		
71463-73A	129	72047-71	121		23	95595-84	53		
71466-65	125	72051-77	23		138		61		
71467-65	125		121		152		147		
71518-80	129	72275-74	121	84850-67	87	96210-80	11		
71550-75	129	72276-74	121		133	99013-82	71		
71552-75	129	72277-74	121	90488-83	91				
71554-75	129	72278-74	85		135				
71563-82A	81		121	90492-83	135				
	127	72310-70	85	90492-86	135				
71564-82A	81	72312-73	85	90493-83	85				
	127	72501-74	89		135				
71567-82	127	72502-74	89	90499-85	135				
71568-82A	127	74406-86	13	90499-86	135				
71570-86A	127		129	90649-85	87				
71571-82	127	74407-86	121	90655-83	135				
71572-86A	127	74516-86	21	90656-83	135				
71573-82A	127	74521-77	23	90657-83A	135				
71574-82	127		121	90657-84	135				
71592-86	127	74526-86	111	90658-83	135				
71593-86	127	74529-79	21	90658-84	135				
71594-86	127	74536-77A	23	90659-83	135				
71595-86	81		121	90683-83	135				
	127	74539-77A	23	90685-83	135				
71806-86	127		121	90688-85	87				
71807-86	127	74589-73	129	90689-84	135				
71875-81	21	74598-73	129	90699-83	135				
72023-51A	55	74599-77A	129	90770-79	43				
72034-71	121	75013-86	111	90821-74A	87				
72035-71	121	75032-86	111	90864-85	135				
72036-71	121	75033-82	97	90866-85	135				
72037-71	121	75034-82	97	90869-85	135				
72038-71	69	75039-86	97	90964-63	87				
	85	76169-86	123	90967-64	87				
	107	76170-86	85	91795-85	135				
	109	76171-86	123	91836-82	135				
	111	76172-86	123	91875-82	117				
	113	76173-86	85	91892-82	117				
	121	76234-86	85	92061-83	109				
	127	76236-86	85		111				
72039-71	97	76243-86	123	92068-83	111				
	109	76244-86	123	92070-86	109				
	111	76248-86	123	92077-83	111				
	113	76249-86	123	95578-41	53				
	115	76250-86A	123		138				
	121	76252-86	123	95581-47	53				
	127	76253-86	123		61				
72040-71	121	76262-86	123		138				

