

HARLEY-DAVIDSON



SPECIFICATIONS
AND
INSTRUCTIONS

COMPETITION RACER

MODEL KR
MODEL KR-TT
MODEL XLR-TT

GENERAL SPECIFICATIONS

	KR	XLR
Engine Type	2 - Cyl. Side Valve	2 - Cyl. O. H. V.
Bore	2-3/4" (2.747")	3" (3.005")
Stroke	3-13/16" (3.8125")	3-13/16" (3.8125")
Piston Displacement	45 cu. in. (750 cu. cm.)	55 cu. in. (883 cu. cm.)
Compression Ratio	Not Available	9.0 to 1
Carburetion	1-1/2" Tillotson	1-1/2" Tillotson
Ignition	Magneto (Horizontal)	Magneto (Horizontal)
Transmission	4-Speed	4-Speed

IMPORTANT

Instructions for breaking in a new KR or XLR engine.

New engines should be run in for approximately 50 miles before racing. The R.P.M. should be kept under 6,000. At the end of the 50 mile run-in, a complete recheck should be made including ignition timing, tappet settings, etc., and the oil be changed.

KR AND KR TT ONLY

For maximum performance, the cylinders should be removed after 100 to 150 miles and rebored (not honed) to the nearest oversize and the valves and seats refaced.

NOTE: The KR engine may be 2 to 4 horsepower below maximum when new.

KR ENGINE SPECIFICATIONS

HEAD GASKET: No head gasket is used. When assembling head to cylinder, clean both surfaces and apply a thin coat of aluminum paint (metallic) as a sealer to both cylinder and head. Heads and cylinders should occasionally be resurfaced on a surface plate using fine emery paper to assure a proper seal.

CYLINDERS: The "KR" cylinders are honed straight to 2.747", and can be rebored .045" oversize and still be within Class "C" regulations. Maximum bore 2.792".

PISTONS: The pistons are cam ground (aluminum). The required clearance between the piston and cylinder head is .035/.040" and it should be checked if the piston, head or cylinder is changed. The pistons are fitted with .007" clearance. Measure for clearance at bottom of skirt. When assembling, piston and rings are to be liberally coated with clean Harley-Davidson 105R oil.

PISTON RINGS: Two 1/16" compression rings and one oil control ring are used on both front and rear pistons. Solid type rings should be set up with a gap of .008" to .010" and should be .002" to .003" loose in the ring groove.

PISTON PIN: Should be a light press fit in piston. When assembling on rod, heat piston just enough so pin can be pushed into piston bosses easily.

CONNECTING ROD: Piston pin in upper end of connecting rod should have .001" to .0015" clearance. The lower connecting rod bearing should have .0016" to .0020" radial clearance. Side clearance between connecting rod bearing retainer and flywheel is .025" minimum.

FLYWHEEL ASSEMBLY: The connecting rods should have from .015" to .018" minimum end play between flywheels. The flywheels when assembled in the crankcase are to have .018" to .022" end play. TAKE EXTREME CARE TO EXCLUDE FOREIGN MATERIAL FROM BEARINGS. The flywheel to crankcase end play is obtained by inserting sprocket shaft bearing thrust washers as required, Catalog No. 24060-26. Flywheel shafts are to be polished to obtain a hand press fit into main bearings.

CAM GEARS: To obtain .001" to .005" end clearance, use shims, Catalog No. 18268-48 and 18269-48R. Insert on crankcase side of cam gear. (See sketch). Polish the cam gear shafts to obtain a hand press fit into cam bearings.

TAPPET GUIDES: Polish to a hand press fit in crankcase.

VALVE SPRINGS: Shim valve springs, when assembling to cylinder, with shims, Catalog No. 18268-48, 18269-48R and 6714, so that dimension, with valve on seat, between the spring collars, is 1-13/64" to 1-7/32", as shown in the sketch. (Valve springs may be shimmed from .080" to .090" before coil binding with valve open.) Valve springs should be inspected periodically and tested for proper poundage as follows: inner - 81 lbs. @ .86"; outer 126 lbs. @ .94".

LUBRICATION: The engine oil should be changed often. CLEAN THE TANK AND OIL LINES THOROUGHLY WHEN OIL IS CHANGED.

CAUTION: Air may become trapped in the oil passages when changing oil, or when oil lines, oil tank and pump have been disconnected for any reason.

For these reasons, always bleed the oil system whenever:

1. Draining tank and refilling with oil.
2. Disconnecting oil lines or removing and replacing tank or oil pump.

Bleeding the oil system:

1. Fill oil tank.
2. Start up the engine and run at idle speed.
3. Loosen plug in nipple at front of oil pump and allow about 3 ounces of oil to drain.
4. Retighten plug after bleeding has been completed.

TAPPET CLEARANCE: With the motor cold, set the tappets to the following clearances:

Exhaust - .010"
Intake - .006"

FAIRBANKS-MORSE MAGNETO: Set KR ignition timing at 38° B.T.C. of front cylinder, or 7/16" B.T.C. of front piston (see sketch).

Magneto safety gap is set at 1/2", when safety gap is used. Magneto point gap is set at .015" (see sketch).

OIL PUMP: The "KR" oil pump turns at 1/4 engine speed instead of 1/2 engine speed as on the standard XL. A by-pass spring determines the oil pressure. It is pre-set at the factory at 15 pounds. Pressure taken at signal switch fitting should be 12 to 15 pounds/sq. in. at 5000 RPM and above with oil hot. Lengthen spring to increase pressure

BREATHER TIMING: Breather timing as recommended for competition motorcycles, breather valve is set to open at 20° to 25° (9/64" to 5/16") after top center (front cylinder). Closing to be 85°/90° A.B.C. (front cylinder). ALL KR engines currently shipped from the factory are timed this way. If it is necessary to remove oil pump, pinion gear, or oil pump spiral gear from engine, and the same parts are reinstalled in engine, breather can be retimed by regular timing method using factory timing marks as shown in Method A. However, if new oil pump, pinion gear, or spiral gear are used to replace original parts, Method B must be used to time breather accurately.

SPARK PLUGS: Motorcycle comes equipped with a Champion N-60R Plugs. Set new plug gaps at .020". The N60R spark plugs are for warm up and break in only.

CARBURETOR ADJUSTMENT: Tillotson diaphragm type H-D5, see sketch.

CARBURETOR ADJUSTMENT: (Linkert MR-4A) the high speed needle should be set at approximately 1-1/2 turns, and the idle needle should be set at approximately 2-1/4 turns. For better acceleration the idle needle is to be set slightly rich. Top of float should be set 3/16" below top flange of bowl. This dimension is obtained by bending float lever with float mechanism out of carburetor. Clearance between head of float valve needle and lever top prongs should be .003" to .005". Check by moving float up and down while holding needle against its seat.

XLR ENGINE SPECIFICATIONS

HEAD GASKET: Standard XL head gasket is used.

CYLINDERS: The XLR cylinders are honed straight to 3.005" which is .005" larger than the XL bore, and can be rebored .045" oversize and still be within Class "C" regulations. Maximum bore 3.050"

PISTONS: The pistons are cam ground, solid skirt aluminum. The pistons are fitted with .005" clearance. Measure piston at bottom of skirt. When assembling, piston and rings are to be liberally coated with clean Harley-Davidson 105R oil.

PISTON RINGS: Two standard compression rings and one oil control ring are used on both front and rear pistons. Solid type rings should be set up with a gap of .008" to .010" and should be .002" to .003" loose in the ring grooves.

PISTON PIN: Should be a light press fit in piston. When assembling on rod, heat piston just enough so pin can be pushed into piston bosses easily.

CONNECTING ROD: Piston pin in upper end of connecting rod should have .001" to .0015" clearance. The lower connecting rod bearing should have .0016" to .0020" radial clearance. Side clearance between connecting rod bearing retainer and flywheel is .025" minimum.

FLYWHEEL ASSEMBLY: The connecting rods should have from .018" to .025" minimum end play between flywheels. The flywheels when assembled in the crankcase are to have .018" to .022" end play. TAKE EXTREME CARE TO EXCLUDE FOREIGN MATERIAL FROM BEARINGS. The flywheel to crankcase end play is obtained by inserting sprocket shaft bearing thrust washers as required, Catalog No. 24060-26. Flywheel shafts are to be polished to obtain a hand press fit into main bearings.

CAM GEARS: To obtain .001" to .005" end clearance, use shims, Catalog No. 18268-48 and 18269-48R. Insert on crankcase side of cam gear (see sketch). Polish the cam gear shafts to obtain a hand press fit in cam bearings.

TAPPET GUIDES: Polish to a hand press fit in crankcase.

VALVE SPRINGS: Shim valves springs, with shims, catalog No. 18245-67R, 18246-67R, 18247-67R, 18241-67R, 18242-67R, 18243-67R so that when valve is fully opened so that inner spring is within .015" of being coil bound and outer spring is within .030" of being coil bound.

LUBRICATION: The engine oil should be changed often. CLEAN THE TANK AND OIL LINES THOROUGHLY WHEN OIL IS CHANGED.

CAUTION: Air may become trapped in the oil passages when changing oil, or when oil lines, oil tank and pump have been disconnected for any reason.

For these reasons, always bleed the oil system whenever:

1. Draining tank and refilling with oil.
2. Disconnecting oil lines or removing and replacing tank or oil pump.

Bleeding the oil system:

1. Fill oil tank.
2. Start up the engine and run at idle speed.
3. Loosen plug in nipple at front of oil pump and allow about 3 ounces of oil to drain.
4. Retighten plug after bleeding has been completed.

TAPPET CLEARANCE: With the motor cold, set the tappets so that push rods have just noticeable shake and can be turned freely with finger tips.

FAIRBANKS-MORSE MAGNETO: Set XLR ignition timing at 48° B.T.C. of front cylinder, or $3/4$ " B.T.C. of front piston. Magneto safety gap is set at $1/2$ ", when used. Magneto point gap is set at .015". (It is recommended that the safety gap be removed).

OIL PUMP: The XLR oil pump turns at $1/4$ engine speed. A bypass spring determines the oil pressure which is pre-set at the factory at 5 pounds and should need no further adjustment.

BREATHER TIMING: Breather timing as recommended for competition motorcycles, breather valve is set to open at 20° to 25° ($9/64$ " to $5/16$ ") after top center (front cylinder). Closing to be $85^{\circ}/90^{\circ}$ A.B.C. All XLR engines currently shipped from the factory are timed this way. If it is necessary to remove oil pump, pinion gear, or oil pump spiral gear from engine, and the same parts are reinstalled in engine, breather can be retimed by regular timing method using factory timing mark as shown in Method A. However, if new oil pump, pinion gear, or spiral gear are used to replace original parts, Method B, must be used to time breather accurately.

SPARK PLUGS: Motorcycle comes equipped with Chamption N-60R plugs. Set new spark plug gaps at .020" for magneto ignition. The N-60R spark plugs are for warm up and break in only.

CARBURETOR ADJUSTMENT: Tillotson diaphragm type H-D 5, see sketch.

CARBURETOR ADJUSTMENT: (Linkert DC) the high speed needle should be set at approximately $1-1/4$ turns, and the idle needle should be set at approximately $1-1/2$ turns. For better acceleration the idle needle is to be set slightly rich.

KR AND XLR TRANSMISSION SPECIFICATIONS

TRANSMISSION MAINSHAFT: To have .003" to .009" end play, which is obtained by selecting one of the following washers - Catalog Nos. 35349-52, .050"; 35350-52, .055"; 35351-52, .060"; 35352-52, .065"; 35353-52, .070"; or 35354-52, .075". This washer is used on right side of transmission between case and mainshaft low gear and is assembled with ear toward countershaft to prevent ear from bending over roll pin.

COUNTERSHAFT SECOND GEAR: Should have between .006" to .013" end play. This is obtained when pressing on countershaft drive gear.

TRANSMISSION COUNTERSHAFT: To have .004" to .009" end play by selecting one of the following washers - Catalog Nos. 35820-52, .050"; 35821-52, .055"; 35824-52, .060"; 35825-52, .065"; 35828-52, .070"; or 35829-52, .075". Place between case and countershaft low gear.

COUNTERSHAFT LOW AND THIRD GEAR CLEARANCE: Clearance between clutch faces of .038" to .058" is obtained by selecting one of the following washers, Catalog Nos. 35840-52, .066"; 35836-55, .075"; 35838-55, .085"; or 35839-55, .099". Place between gears.

SHIFTER FORKS: To have a minimum of .004" end play in gear groove. Grind new forks as required. Replace fork if over .015" side play in groove.

KICK STARTER CLUTCH: Care must be taken to maintain a minimum of .040" clearance between kick starter clutch and clutch sprocket. This can be checked in the following manner:

1. Assemble kick starter mechanism including spring, sprocket spacer, starter clutch, gear and sector parts.
2. Measure distance from end of clutch sprocket spacer to top of starter clutch gear teeth.
3. On clutch sprocket assembly, measure distance from top of starter teeth to clutch sprocket thrust washer.
4. Subtract the sprocket reading (3) from the clutch gear reading (2).
5. A minimum of .040" must be had; if not, obtain proper clearance as follows:

KR: Use collar, Catalog No. 37756-57, .020", placing between clutch sprocket spacer and clutch sprocket.

XLR: Substitute longer sprocket collar, Catalog No. 37755-57.

FRONT CHAIN ADJUSTMENT: After chain is installed, adjust shoe so that 3/4" slack is obtained, in the chain midway between the sprockets - engine cold.

LUBRICATION: Transmission and chain case are lubricated by a connecting passage with 16 ounces of Harley-Davidson 75R oil.

FORKS: KR, KR-TT AND XLR-TT

FRONT HYDRAULIC FORK: When forks are disassembled and reassembled (DRY) 4-1/2 ounces of oil should be put into each fork side. When forks are drained, 4 ounces of oil should be put into each fork side. The difference is due to oil cling and the fact that it is not possible to drain all oil from the forks. Use Harley-Davidson 75R oil.

REAR FORK TIMKEN BEARING: This is a pre-loaded bearing. The adjustment is made on right side of frame. With bearing adjusted perfectly free, weigh extreme rear end of fork. Attach spring scale and raise fork to the horizontal position with centerline of frame. Take scale reading. Tighten bearing adjusting nut a sufficient amount to provide from one to two pounds drag on the bearing when scale is raised further. For example, if rear end of fork weighs three and one-half pounds with bearings free, bearings should be adjusted tight enough to make the fork weight four and one-half to five and one-half pounds.

TILLOTSON CARBURETOR ADJUSTMENT

SINGLE CARBURETOR, H-D5A (#27155-66RA)

PRELIMINARY ADJUSTMENTS: Low speed - 1 to 1-1/4 turns open; intermediate - 1-1/8 to 1-3/8 turns open; high speed - 1 to 1-1/2 turns open. The adjustable needles control fuel, therefore by turning the needles out counterclockwise the mixture will become richer.

CAUTION: Adjustment of the intermediate jet is extremely important for proper carburetion. To properly adjust, the engine must be HOT. Rev the engine between 3000 and 6000 RPM's opening the intermediate jet slightly each time the engine is revved thru this RPM range. This should be repeated until the engine is smooth and without hesitation. Final adjustment will be approximately 1-1/8 to 1-3/8 turns open.

DUAL CARBURETORS (#27146-69R and 27153-69R)

NOTE: The front carburetor, 27146-69R, is equipped with a low speed adjustable jet. The rear carburetor, 27153-69R, is not equipped with this adjustment but is preset (see sketch for details of assembly). Throttle discs must be synchronized for proper acceleration and adjustment.

PRELIMINARY ADJUSTMENTS:

Front carburetor: low speed - 1-1/8 turns; intermediate - 1-1/4 turns; high speed - 1-3/4 to 2 turns.

Rear carburetor: low speed - fixed; intermediate - 1-1/4 turns; high speed - 2 to 2-1/4 turns.

The adjustable needles control fuel therefore by turning the needles out counterclockwise the mixture will become richer. Final adjustment of carburetors must be determined with spark plug checks.

CAUTION: Adjustment of inlet valve lever is extremely important and should be checked. See the following sketch.

ADJUSTMENT OF INLET VALVE LEVER:

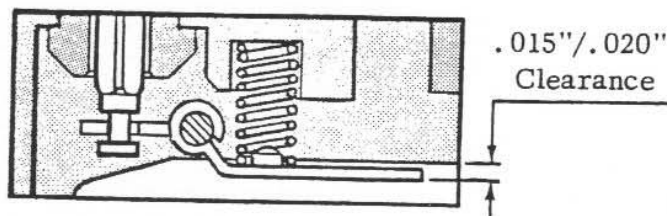

If it becomes necessary to adjust the intermediate needle richer than 1-1/2 turns, the cause is usually a low needle lever setting.

NOTE: It is suggested that a gas line filter (62351-69R) be used with these carburetors. The filter must be mounted in a vertical position.

"SERVICE TIPS - DIAPHRAGM CARBURETOR"

1. Clean or inspect inlet needle and seat assembly and inlet screens.
2. Correctly adjust inlet control lever so that the end at the center of the chamber is .015" to .020" out of the casting.
3. Check the economizer ball-check valve. The ball must move in the casting.
4. Check the nozzle ball check and retainer, to see that they are in place.
5. Inspect the diaphragm plate rivet. It must be tight. The plate should not rotate.
6. Check assembly order. The gasket is placed onto the body casting; the diaphragm is placed onto the gasket, and the cover plate is placed onto the diaphragm.
7. Tighten the cover-plate screws.
8. Check all passages.

C A M T I M I N G S P E C ' S

"J" & "K" Cams KR & KRTT (25499-69R)

J - In. Opens	66°	BTC	+	2°
J - In. Closes	66°	ABC	+	2°
K - Ex. Opens	58°	BBC	+	2°
K - Ex. Closes	42°	ATC	+	2°

Timing checked at .010" valve lift with no tappet clearance.

Valve lift: intake .395"
exhaust .395"

Tappet clearance: intake .006" (eng. cold)
exhaust .010" (eng. cold)

"J" & "L" Cams KR & KRTT (25498-69R)

J - In. Opens	66°	BTC	+	2°
J - In. Closes	66°	ABC	+	2°
L - Ex. Opens	65°	BBC	+	2°
L - Ex. Closes	40°	ATC	+	2°

Timing checked at .010" valve lift with no tappet clearance.

Valve lift: Intake - .395"
Exhaust - .395"

Tappet clearance: intake .006" (eng. cold)
exhaust .010" (eng. cold)

"PB" Cams XLR & XL

Intake opens	77°	BTC
Intake closes	87°	ABC
Exhaust opens	92°	BBC
Exhaust closes	74°	ATC

Timing checked at .005" tappet lift with no tappet clearances.

Valve lift: intake .400"
exhaust .400"

"P" Cams XLR & XL

Intake opens	82°	BTC
Intake closes	82°	ABC
Exhaust opens	85°	BBC
Exhaust closes	80°	ATC

Timing checked at .005" tappet lift with no tappet clearance.

MODEL KR & XLR FLYWHEEL AND CAMGEAR ASSEMBLIES

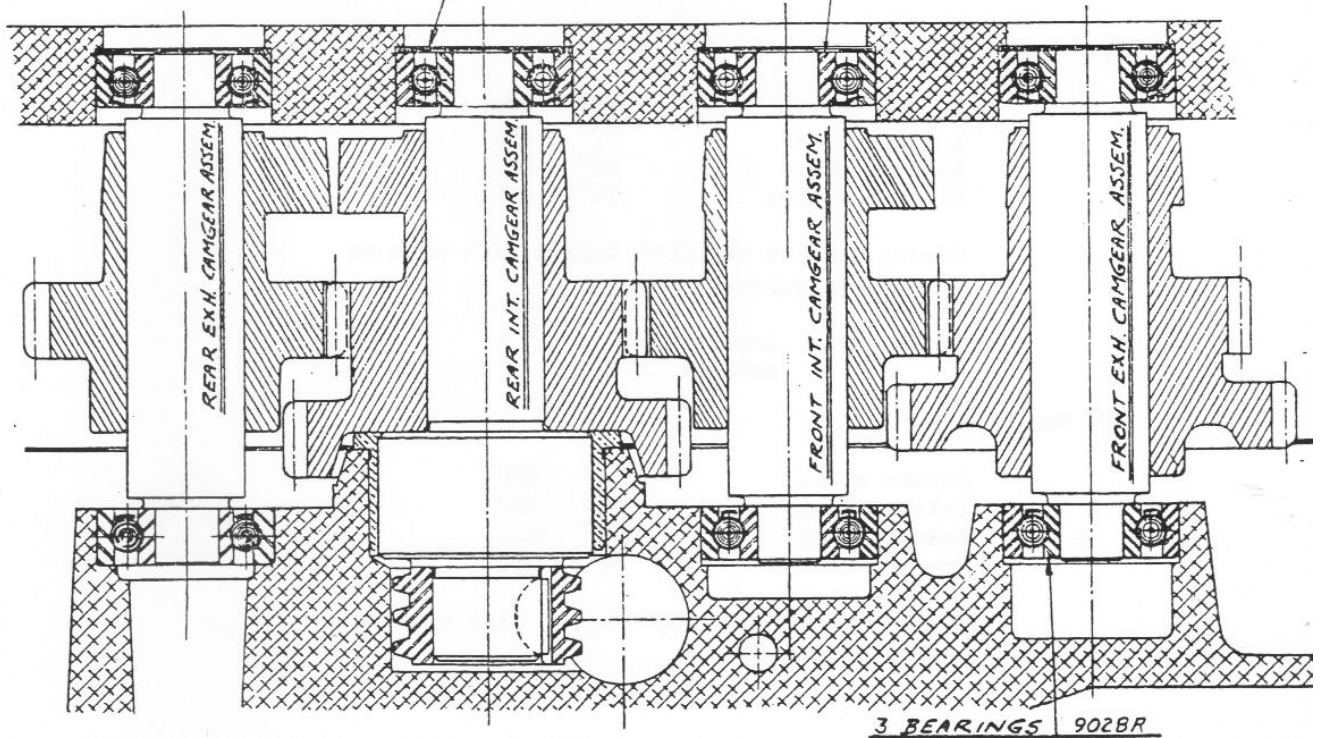
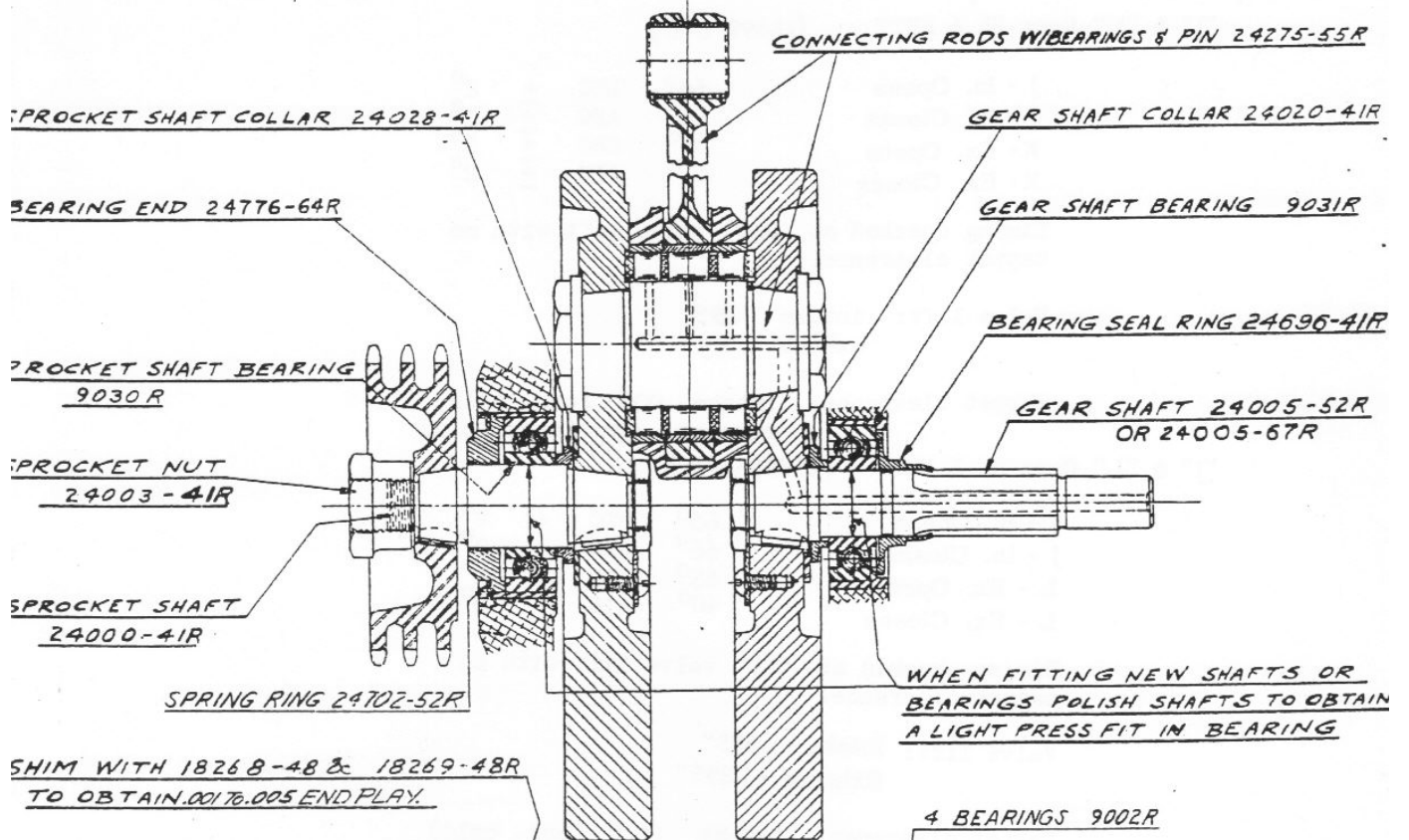

MODEL "KR" VALVE SPRING SETUP. "KR" & "XLR" IGNITION TIMING

DESIRED VALVE TO HEAD CLEARANCE CHECKED WITH STANDARD VALVE - .120" INTAKE AND .080" EXHAUST. FOR MAXIMUM PERFORMANCE, CORRECTIONS SHOULD BE MADE.

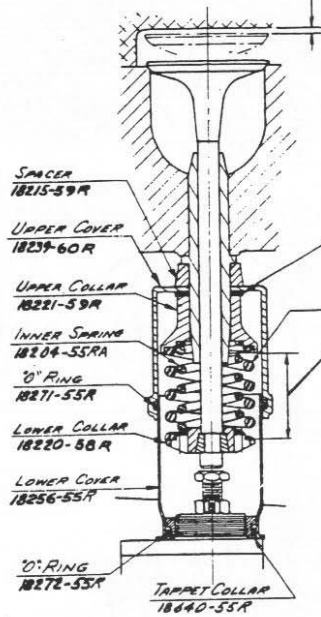

NOTE:
CLEARANCE BETWEEN PISTON AND HEAD WITH PISTON AT TOP DEAD CENTER - MIN. OF .040 TO .045"

VALVE SPRING SETUP: INTAKE & EXHAUST
INSERT SHIMS CATALOG NUMBERS 6714(.030), 18268-48(.015") AND 18269-48R(.007") TO OBTAIN A SPACE OF $1\frac{1}{8}"$ TO $1\frac{1}{32}"$ BETWEEN THE UPPER SPRING COLLAR & THE LOWER SPRING COLLAR AS SHOWN. THIS SETUP IS MADE WITH "VALVE SPRING UPPER COVER" IN PLACE.

OUTER SPRING 18203-55RA

$1\frac{1}{8}"$ TO $1\frac{1}{32}"$

OR SHIM SPRINGS TO WITHIN .080" TO .090" OF BEING COIL BOUND WHEN VALVE IS OPEN.

IGNITION SHOULD BE TIMED TO OCCUR WITH FLYWHEEL TIMING MARK IN POSITION SHOWN

MODEL "KR"

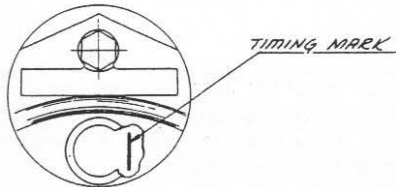

36° ($7\frac{1}{16}$) B.T.C
FRONT CYLINDER PISTON

MODEL "XLR"

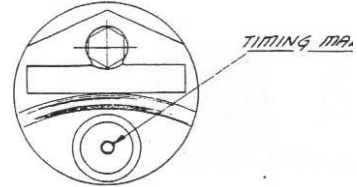

48° ($3\frac{1}{4}$) B.T.C
FRONT CYLINDER PISTON

BREATHER TIMING ~ METHOD A:

SET FLYWHEEL TIMING MARK. See Fig. 1. BREATHER PINION SHAFT GEAR (SPIRAL GEAR) AND SHAFT ARE SPLINE ENGAGED. A BEARING OIL SEAL RING AND SPRING ARE ASSEMBLED BEHIND IT. SPRING PUSHES SPIRAL GEAR OUTWARD TIGHT AGAINST PINION GEAR AND BEARING OIL SEAL RING INWARD TIGHT AGAINST CRANKCASE BEARING BUSHING. A MARK IS CUT IN ONE SIDE OF SPIRAL GEAR. ASSEMBLE WITH MARKED SIDE OUTWARD (AGAINST PINION GEAR) SET PINION GEAR. See Fig. 2

Fig. 1

SET FLYWHEEL TIMING MARK EXACTLY IN CENTER OF TIMING INSPECTION HOLE, WHICH IS 30° B.T.C. (FRONT CYLINDER)

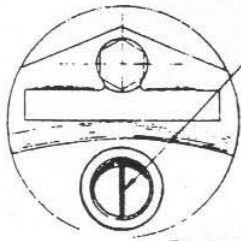

BREATHER VALVE OPENS AT 25° A.T.C. (FRONT CYLINDER)

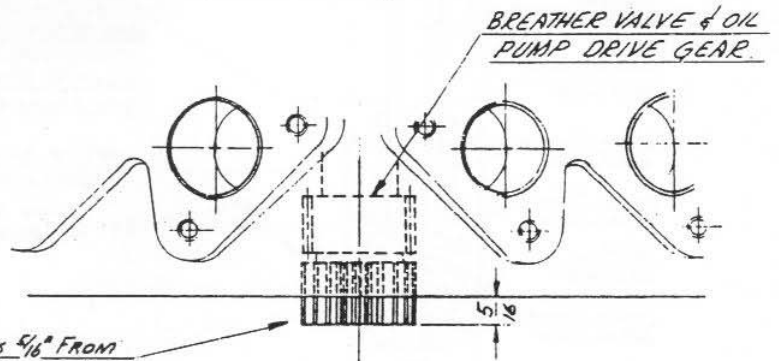

BREATHER VALVE & OIL PUMP DRIVE GEAR.

WHEN PINION GEAR IS $\frac{5}{16}$ " FROM GEAR CASE FACE, TIMING HOLE IN BREATHER SLEEVE SHOULD REGISTER APPROX. IN CENTER OF SLOT ON PUMP BODY

OIL PUMP BREATHER VALVE GEAR.

Fig. 2

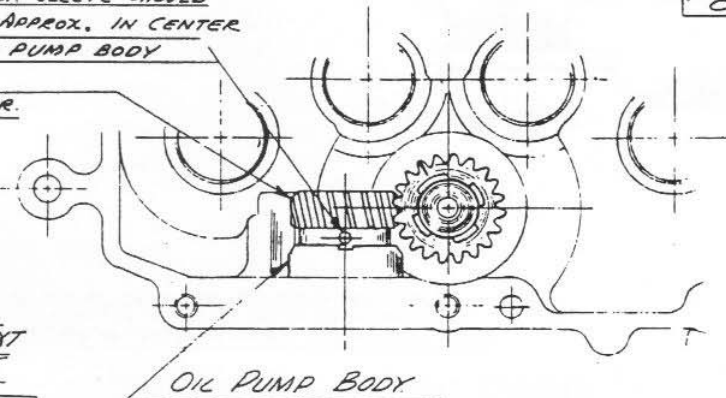

OIL PUMP BODY

BREATHER TIMING ~ METHOD B

BEFORE INSTALLING OIL PUMP TURN GEAR COUNTER CLOCKWISE UNTIL SLEEVE HOLE CROSSES SLOT IN PUMP BODY. SCRIBE MARK ACROSS SLEEVE AND BODY AT SLOT WHEN NEXT OPENING IN SLEEVE STARTS TO OPEN (USE .02" SHIM IN OPENING). See Fig. 3

Fig. 3

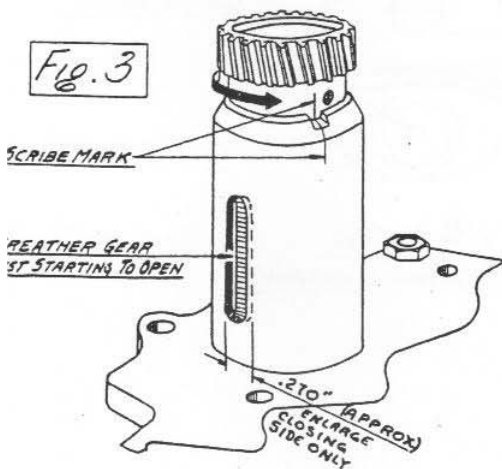

SCRIBE MARK

BREATHER GEAR JUST STARTING TO OPEN

.210" (APPROX) ENLARGE CLOSING SIDE ONLY

IGNORE FLYWHEEL TIMING MARK. SET FRONT CYLINDER PISTON $\frac{9}{64}$ " TO $\frac{5}{16}$ " (25°) A.T.C. INSTALL PUMP-ENGAGING PROPER GEAR TEETH TO LINE UP. SCRIBE MARKS WHEN PINION GEAR IS SET $\frac{5}{16}$ " FROM GEAR CASE FACE.

IF MARKS DO NOT LINE UP:
 - SLEEVE MARK SLIGHTLY TO RIGHT OF BODY MARK - GRIND STOCK FROM ENGINE SIDE FACE OF PINION GEAR OR USE NARROWER PINION GEAR.
 - SLEEVE MARK SLIGHTLY TO LEFT OF BODY MARK - USE PT. No. 18268-48 (.015" THICK) WASHER BETWEEN PINION AND PUMP DRIVE GEARS, OR USE WIDER PINION GEAR. BREATHER VALVE SHOULD CLOSE AT 85° A.B.C. TO OBTAIN THIS TIMING, ENLARGE THE OIL PUMP COVER SLOT BY FILING THE CLOSING SIDE ONLY TO DIMENSION SHOWN.

MODELS "KR" AND "XLR" TRANSMISSION ASSEMBLY

MAINTAIN A MIN. OF .040" CLEARANCE
BETWEEN "KICK STARTER CLUTCH" AND
"CLUTCH SPROCKET" BY USING SHIMS
CATALOG N^o 33450-54-020".

TO OBTAIN .003"-.009" END PLAY, SELECT
ONE OF THE FOLLOWING WASHERS:
CATALOG N^os. 35349-52-.050",
35350-52-.055", 35351-52-.060",
35352-52-.065", 35353-52-.070",
35354-52-.075". ASSEMBLE WITH EAR
TOWARD COUNTERSHAFT TO PREVENT
EAR FROM BENDING OVER ROLL PIN.

MAINSHAFT SPROCKETS:

- 15T # 35200-53R
- 16T # 35201-53R
- 17T # 35202-53R
- 18T # 35205-52RA
- 19T # 35197-52R
- 20T # 35206-52RA
- 21T # 35205-52A
- 22T # 35205-54
- 23T # 35198-53R
- 24T # 35198-58R

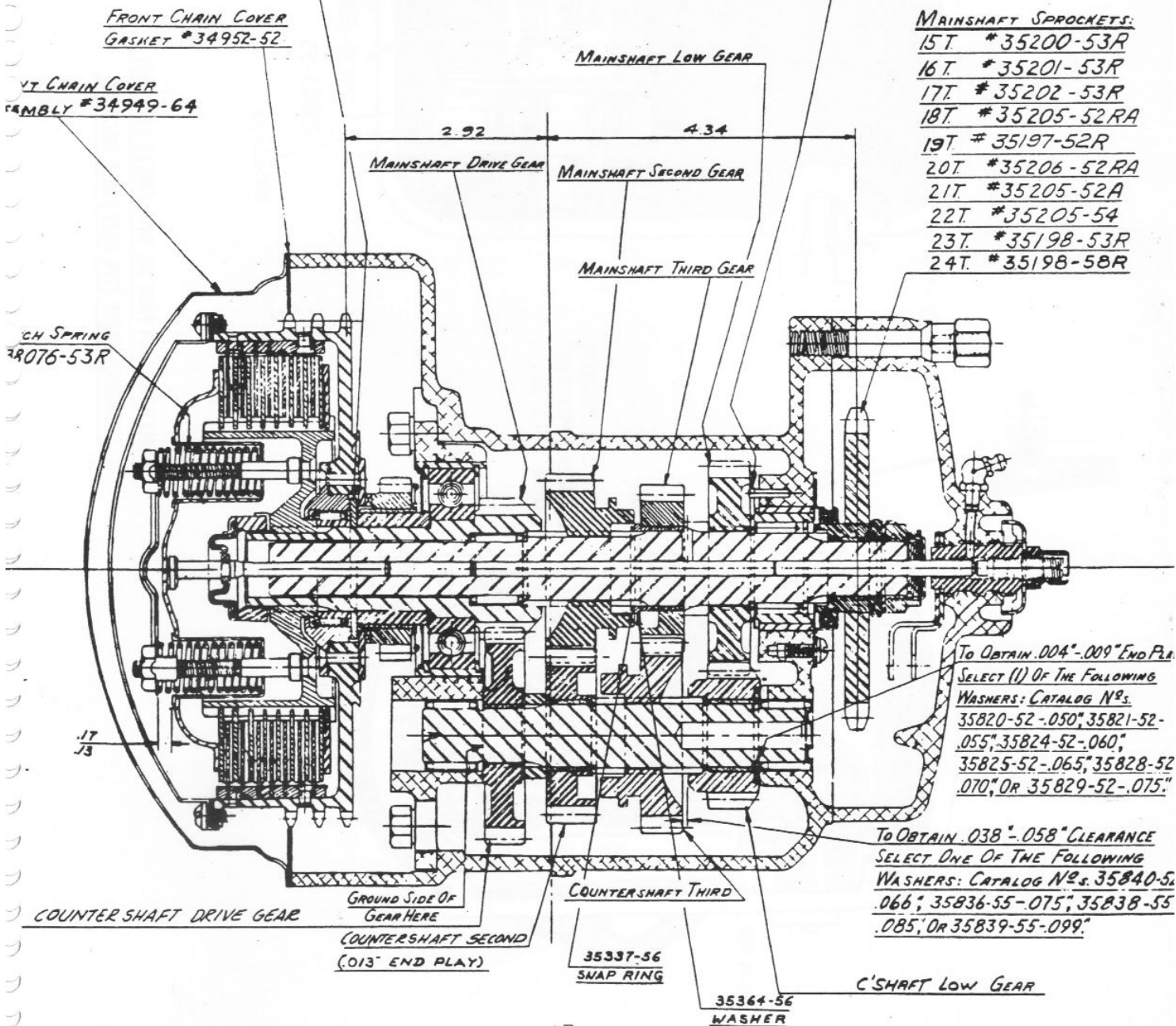

TO OBTAIN .004"-.009" END PLAY,
SELECT (1) OF THE FOLLOWING
WASHERS: CATALOG N^os.
35820-52-.050, 35821-52-
.055, 35824-52-.060,
35825-52-.065, 35828-52
.070, OR 35829-52-.075."

TO OBTAIN .038"-.058" CLEARANCE
SELECT ONE OF THE FOLLOWING
WASHERS: CATALOG N^os. 35840-52-
.066, 35836-55-.075, 35838-55-
.085, OR 35839-55-.099."

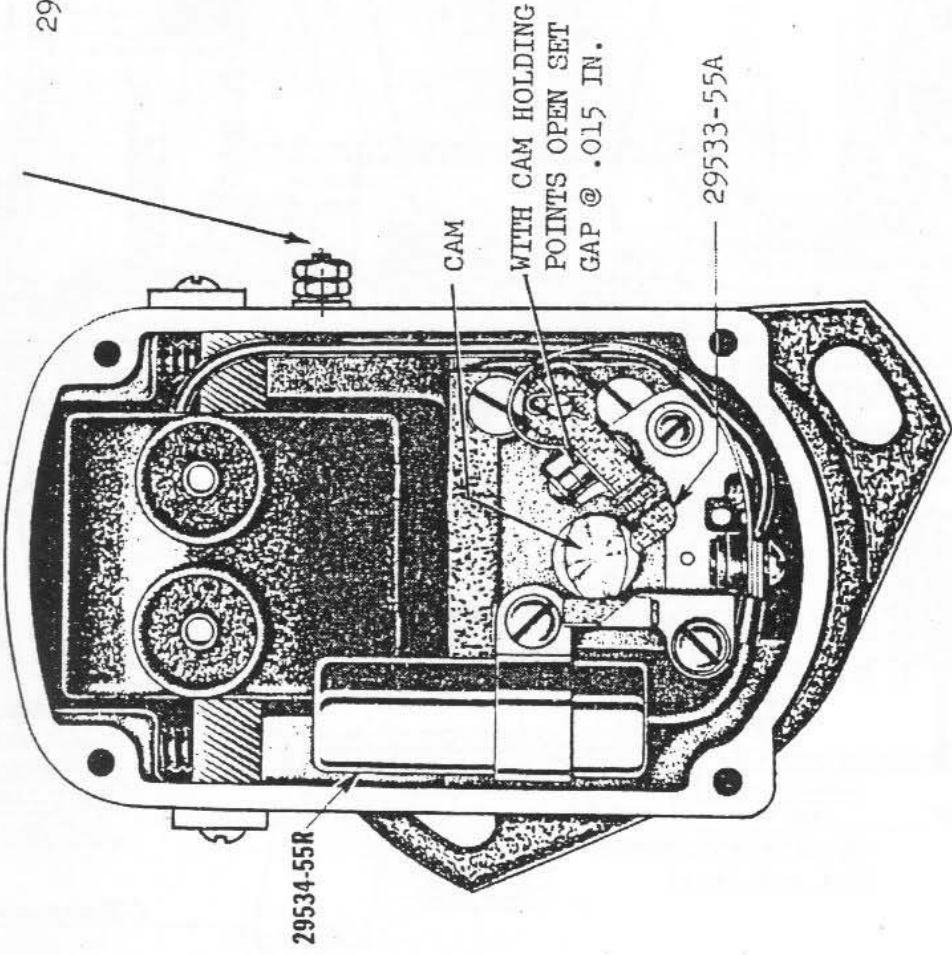
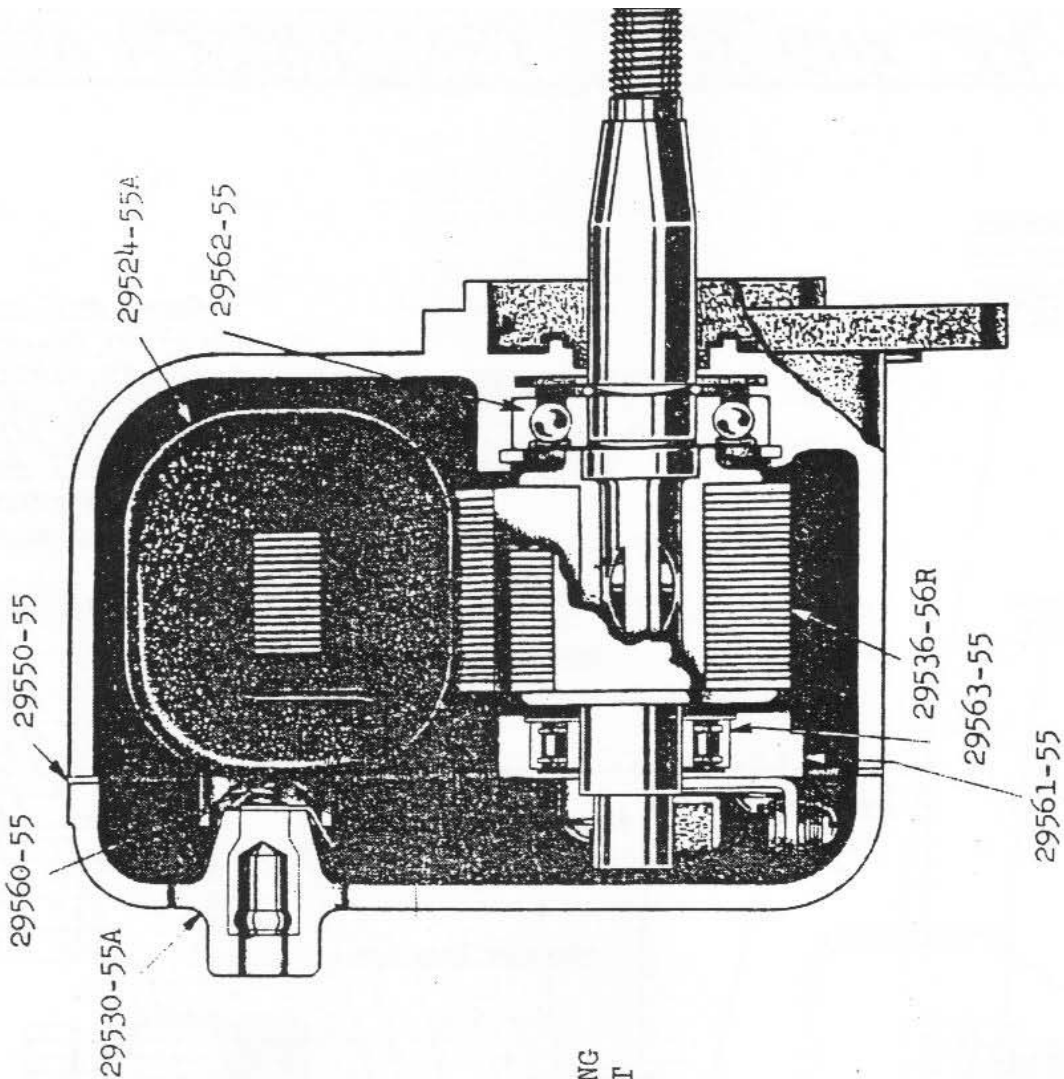
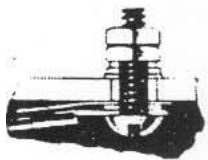

HARLEY-DAVIDSON PART NO. WITH CABLES 29500-56R
 FAIRBANKS-MORSE TYPE FMZ2-2863B MAGNETO

ADAPTION OF TILLOTSON CARBURETOR TO KR & KRTT

MODIFIED CARB.- SEE SKETCH PAGE 18

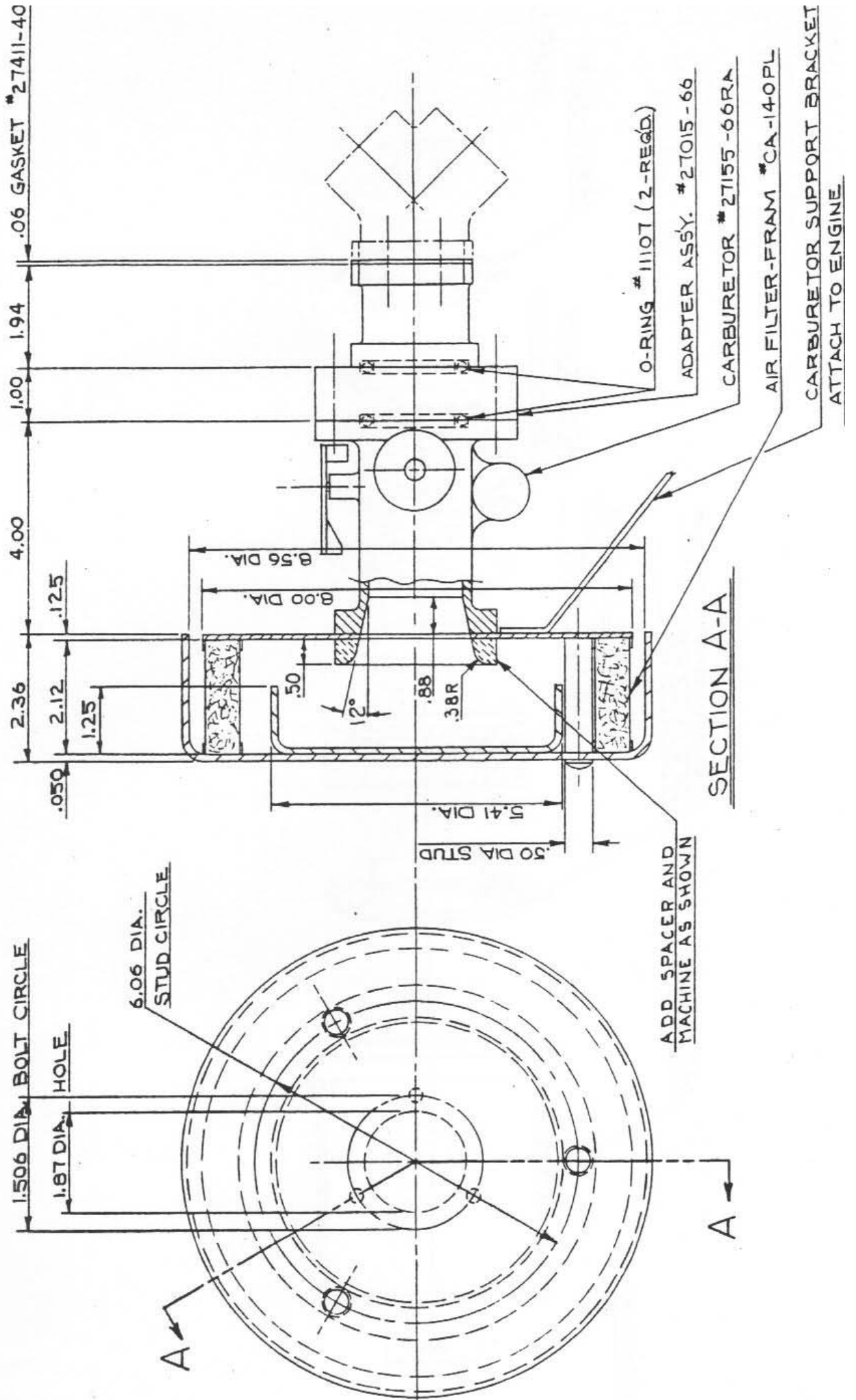

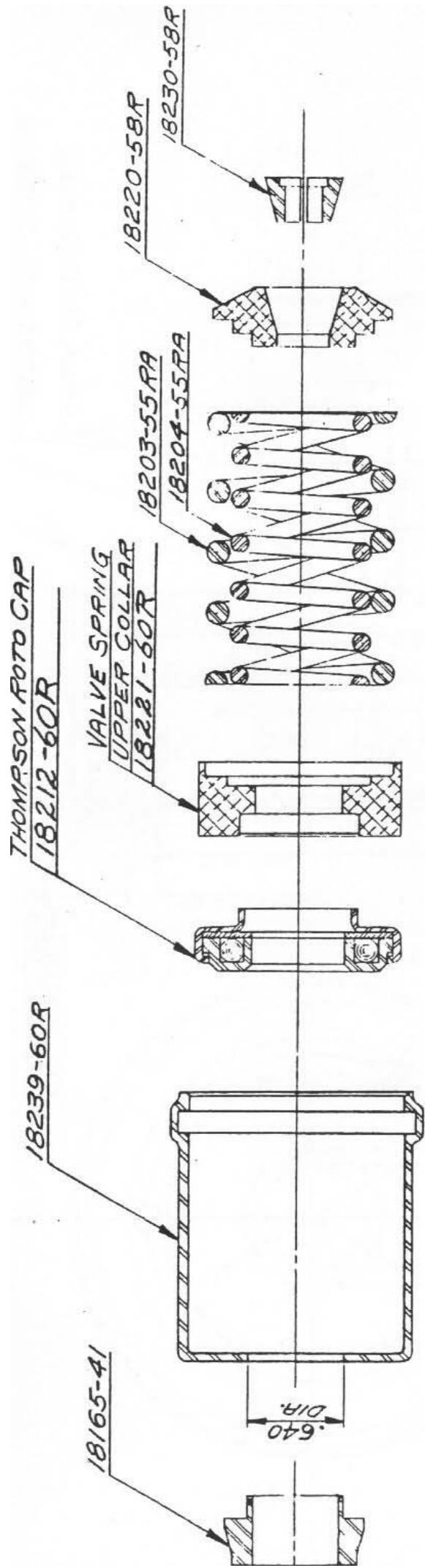

HARLEY-DAVIDSON MOTOR CO.

KR VALVE SPRING & COLLAR
LAYOUT USING FOTO CAPS

KR & KR TT VALVE MODIFICATIONS

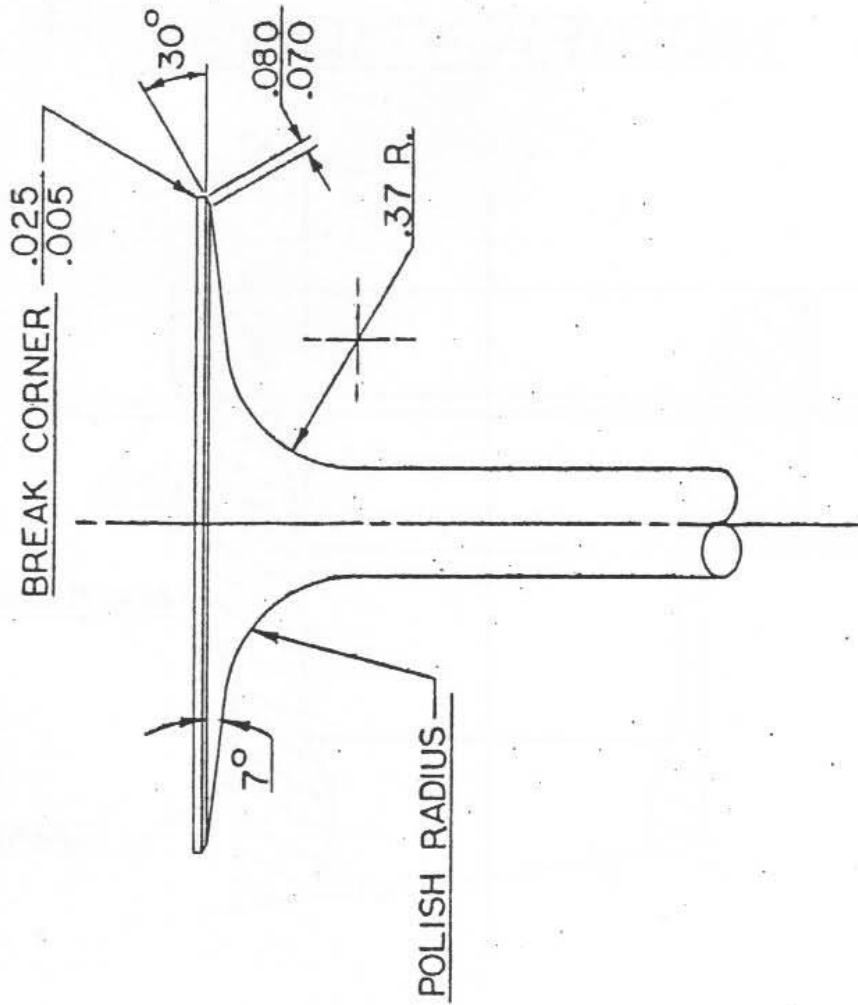

LIGHTENED INTAKE VALVE

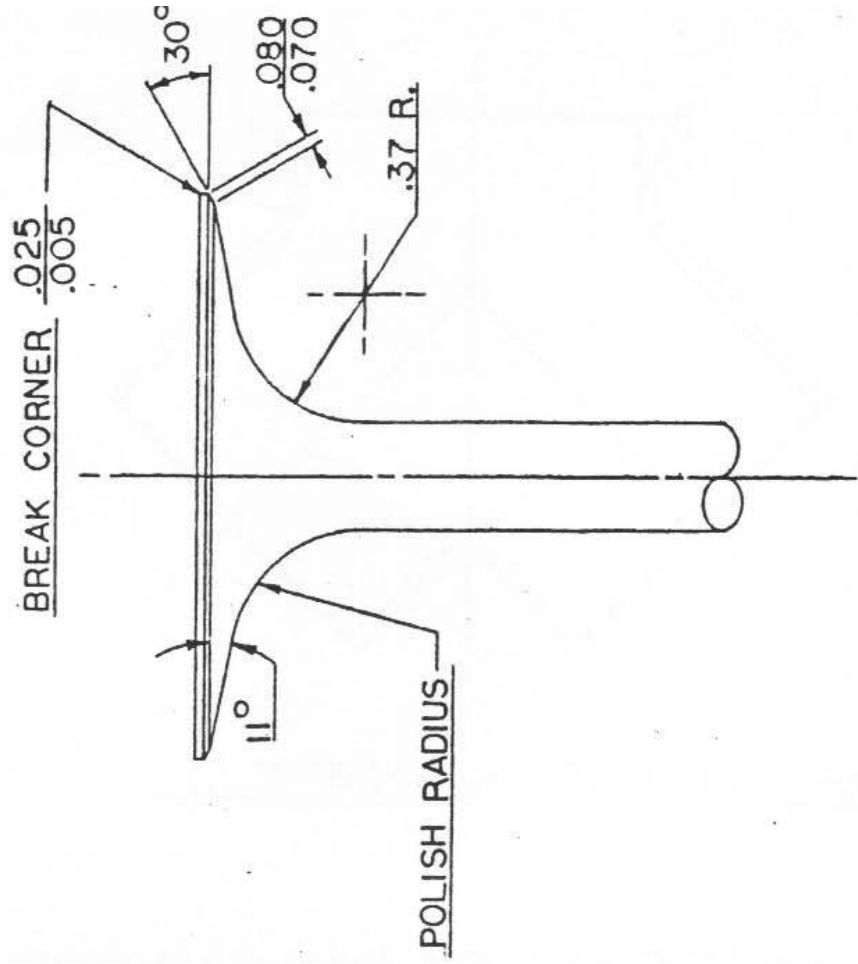

LIGHTENED EXHAUST VALVE

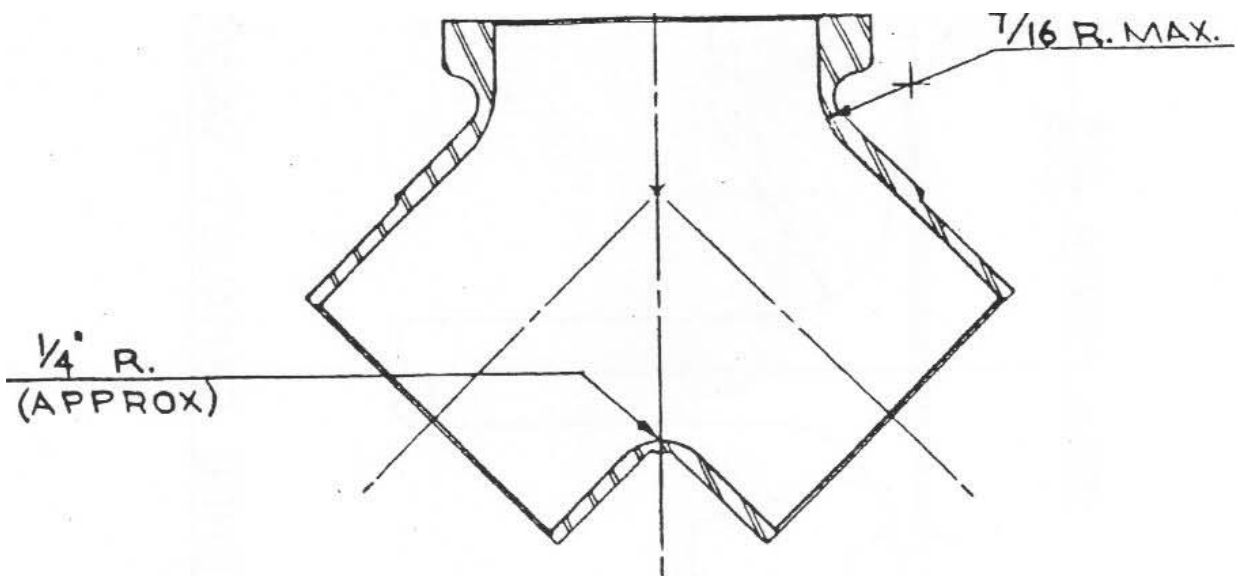

KR INTAKE MANIFOLD

TILLOTSON CARBURETOR
MODIFICATIONS

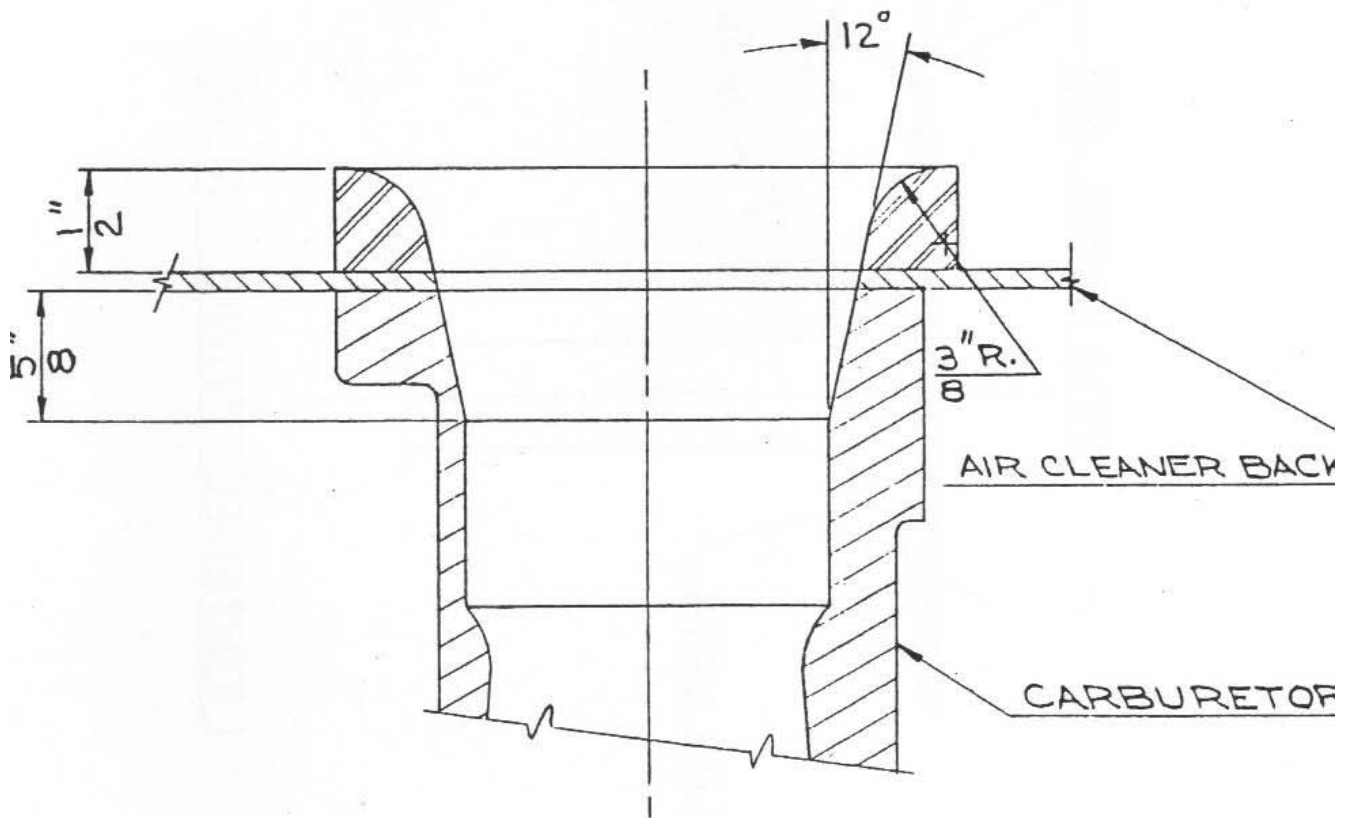

KR - XLR MODELS

METHOD FOR CORRECTING CLEARANCE OVER VALVES

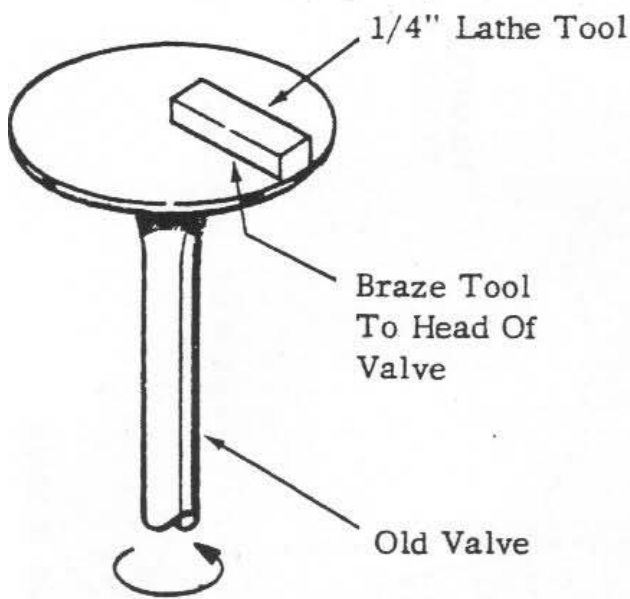

For correcting clearance over intake and exhaust valve a 1/4" lathe tool may be brazed to the top of an old valve as shown and sharpened.

The valve may now be installed in the cylinder, bolt on cylinder head, and with a drill turning the valve, the head may be recut to obtain the correct clearance.

(SEE PAGE)

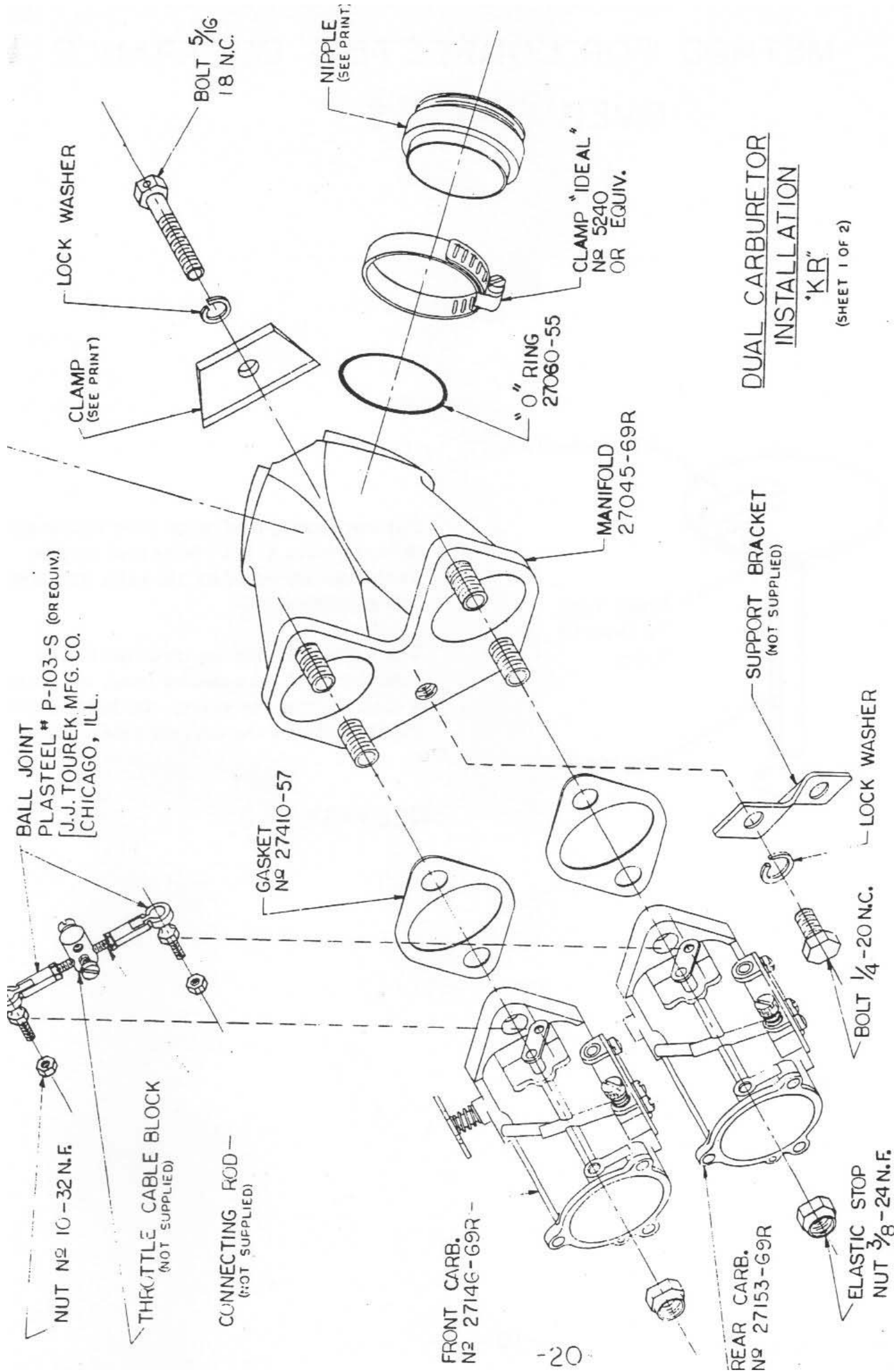

**DUAL CARBURETOR
INSTALLATION**

KR
(SHEET 1 OF 2)

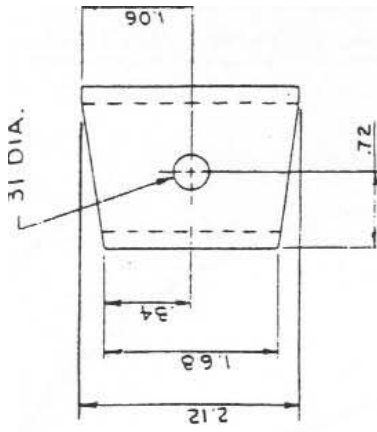

CLAMP
MAT.-STEEL

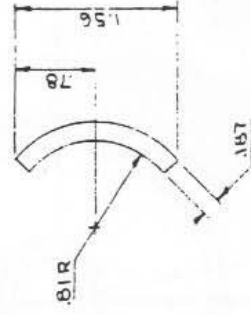
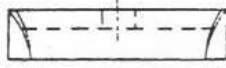

REMOVE EXCESS MATERIAL

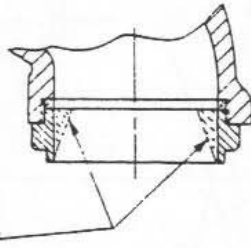

REMOVE EXCESS MATERIAL FROM INSIDE OF NEW NIPPLE TO MATCH PORT.

BRAZE ALL AROUND USING $\frac{1}{8}$ " ALLSTATE EUTECTIC ROD # 16-F.C. OR EQUIV. PREHEAT CYLINDER BEFORE BRAZING.

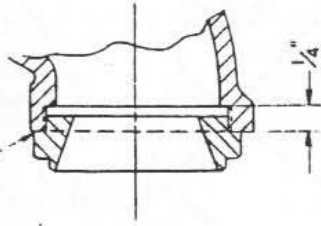

STEP TWO: MACHINE CYLINDER TO DIMENSION SHOWN. BRAZE NEW NIPPLE IN PLACE.

INTAKE PORT

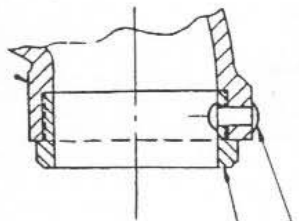

NIPPLE
RIVET

STEP ONE: REMOVE NIPPLE AND RIVET.

NIPPLE INSTALLATION

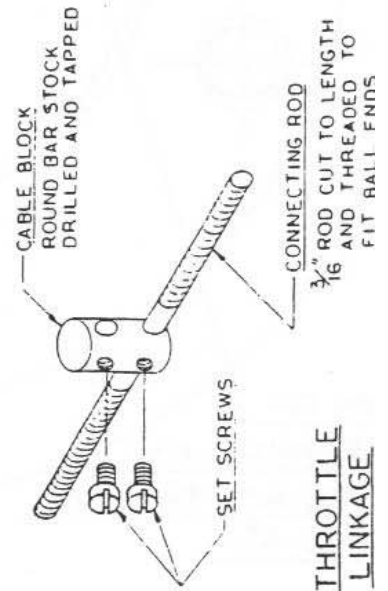
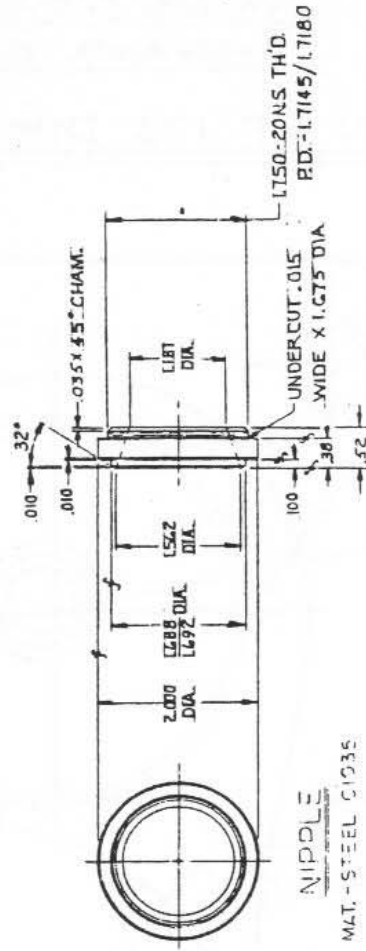

THROTTLE LINKAGE

NOTE: CYL. RELIEF AREA AND AREA AROUND
VALVE TO BLEND AND MATCH COMBUSTION
CHAMBER IN CYL. HEAD.

LOCATION OF .173 DIMENSION

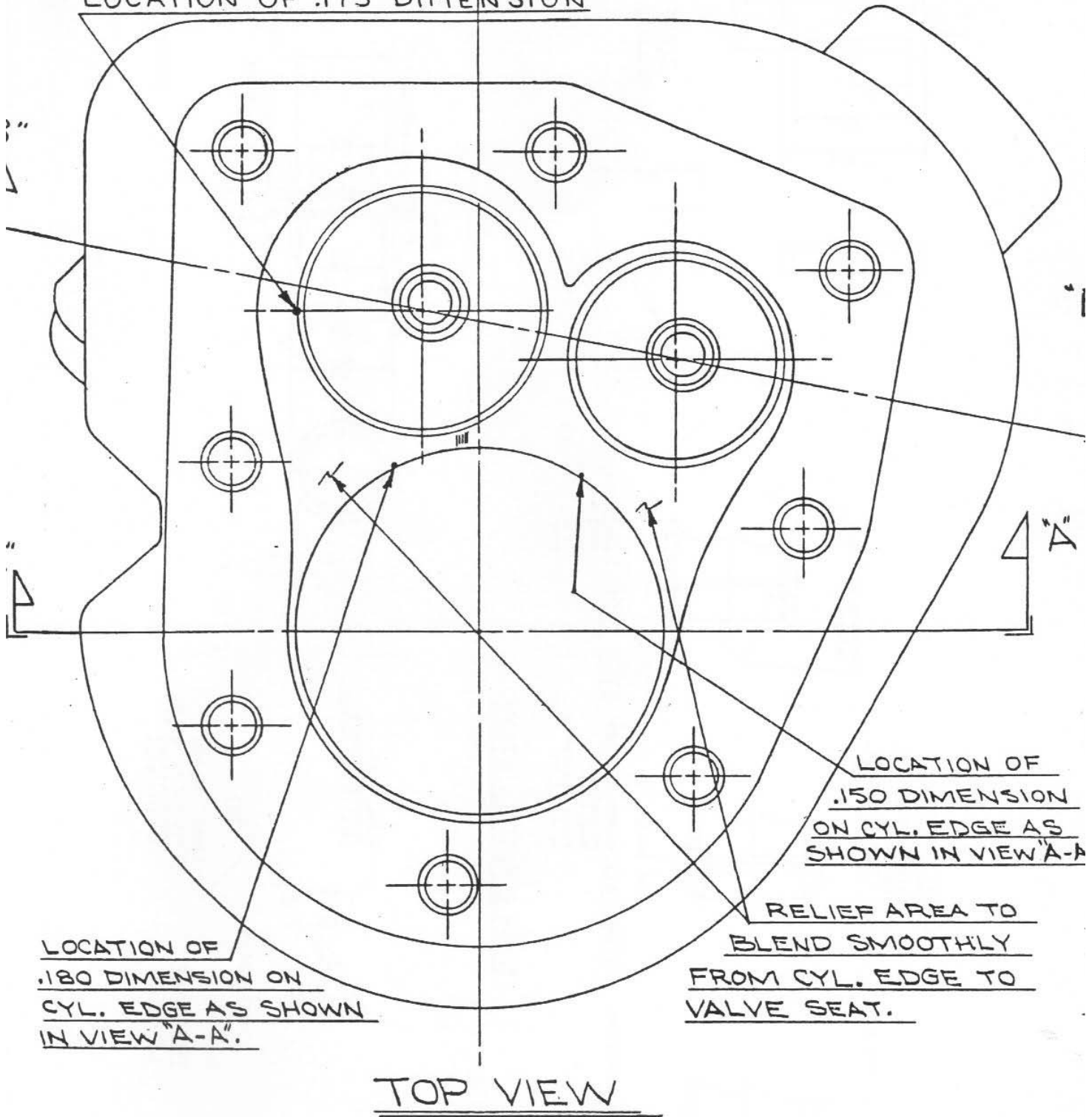

LOCATION OF
.150 DIMENSION
ON CYL. EDGE AS
SHOWN IN VIEW "A-A"

RELIEF AREA TO
BLEND SMOOTHLY
FROM CYL. EDGE TO
VALVE SEAT.

LOCATION OF
.180 DIMENSION ON
CYL. EDGE AS SHOWN
IN VIEW "A-A".

TOP VIEW

CAUTION: DO NOT RADIUS TOP
EDGE OF CYLINDER
BORE.

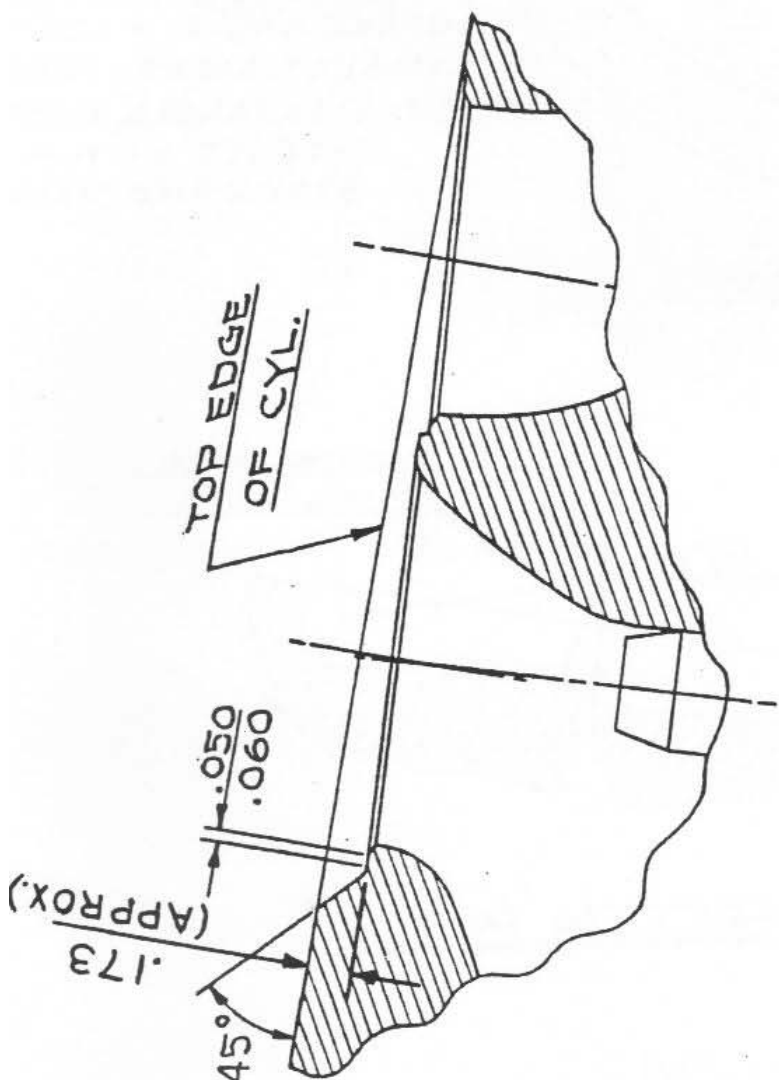

SECTION "B-B"

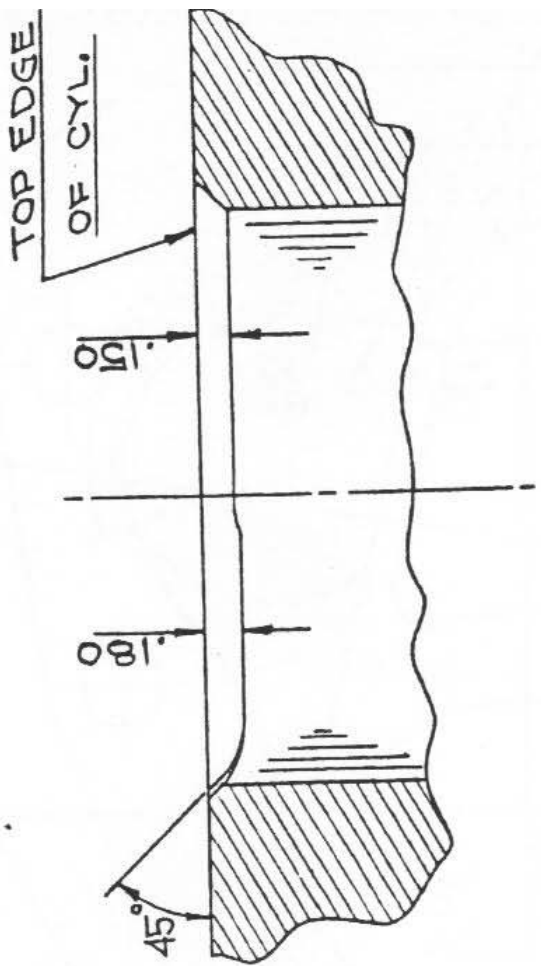

VIEW "A-A"

SHOWING CYL. EDGE
OF RELIEF AREA

BE FLAT, AND PARALLEL TO THE TOP OF THEIR RESPECTIVE VALVE HEADS.

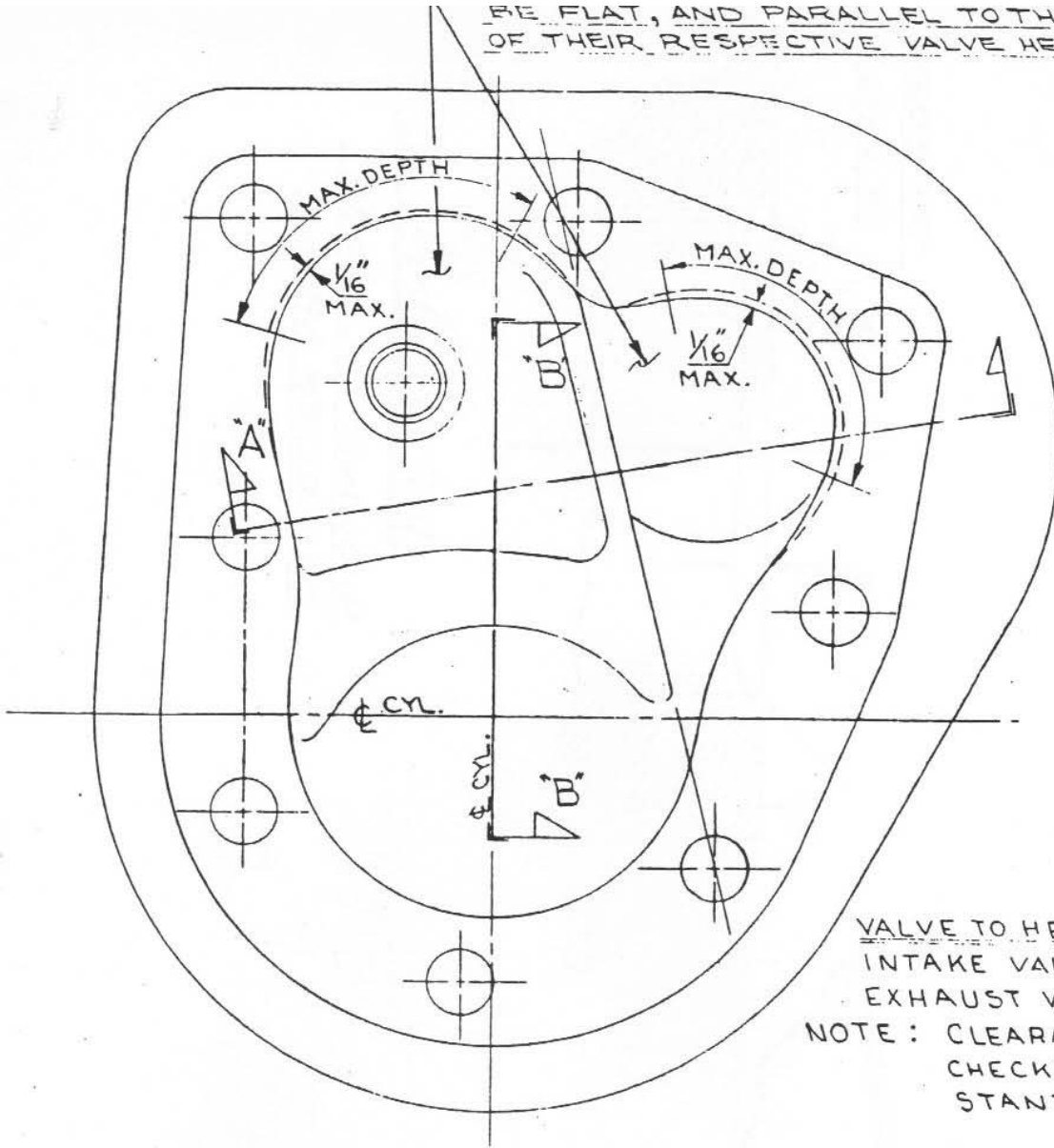

VALVE TO HEAD CLEARANCES
 INTAKE VALVE = .120" MIN
 EXHAUST VALVE = .080"
 NOTE: CLEARANCES MUST BE CHECKED WITH A STANDARD VALVE.

BOTTOM VIEW

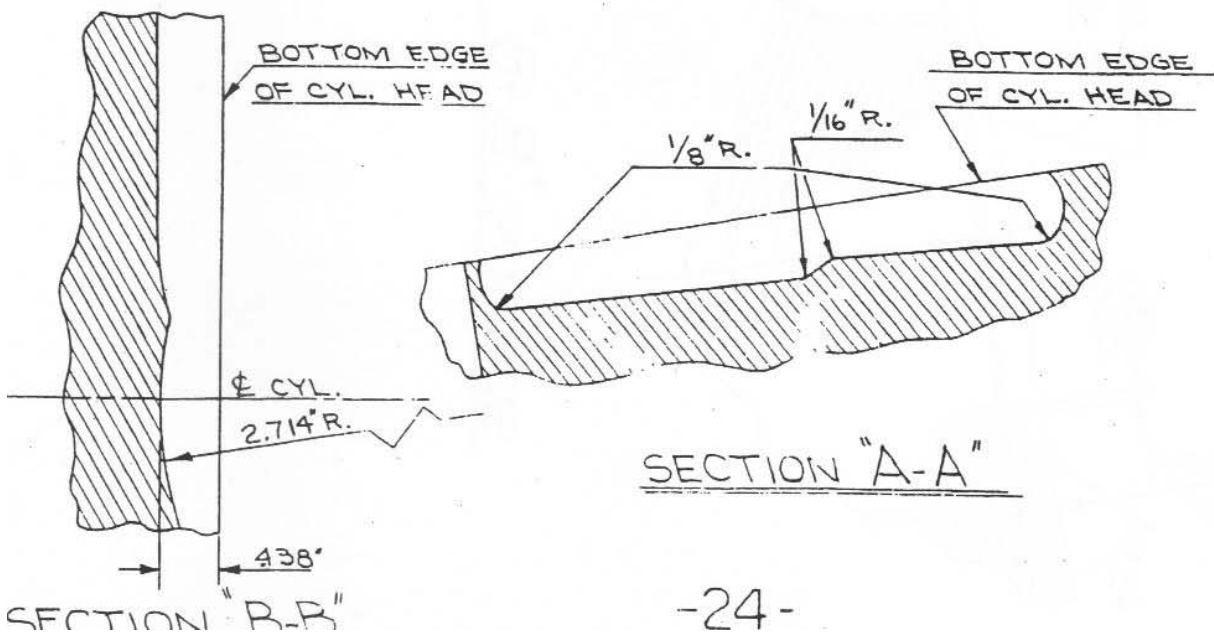

SECTION "A-A"

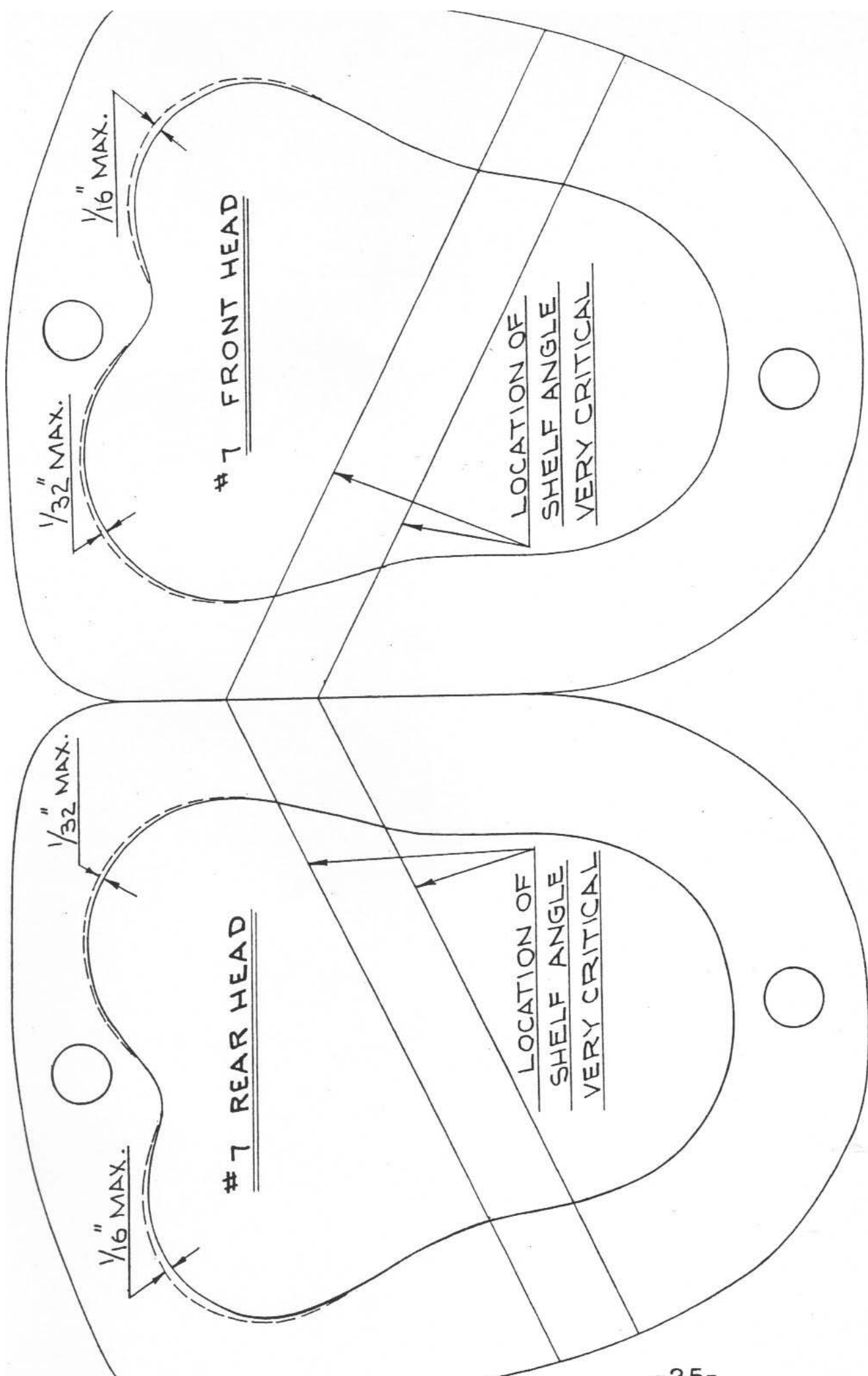

MODIFICATIONS FOR XL MODELS

Install intake valve, part number 18069-65R (1 15/16" dia.).

Do not enlarge the intake port except to blend the enlarged valve seat to the present intake port diameter (see illustration). A smooth radius must be obtained.

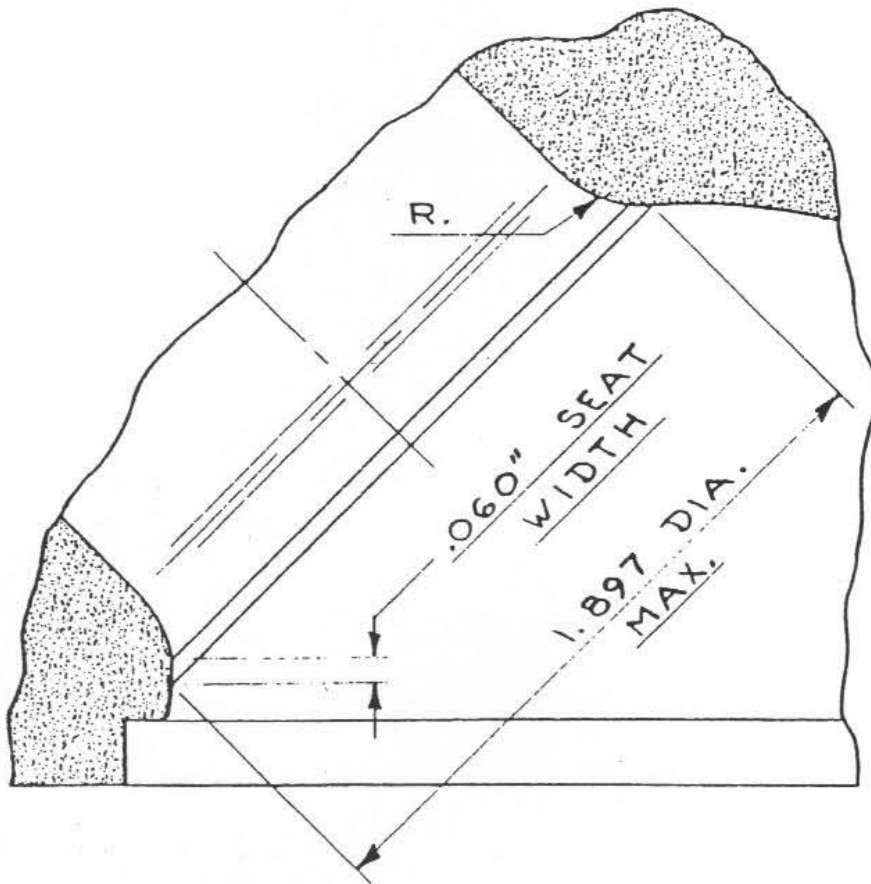

NOTE: A minimum of .060" clearance is required between the valve and the piston. This may be checked by using modeling clay in the valve pocket and rotating the engine with the cylinder head installed.

Polish the intake and exhaust ports and intake manifold:

Caution: Do not remove excessive amounts of material. This will only decrease performance.

Shim the valve springs, Shims, part number 6649, should be installed under the lower valve spring collar until inner valve spring is within .015" of being coil bound and outer valve spring is within .030" of being coil bound when the valve is fully open.

Install the "PB" cam gear set, part number 25460-66R. Cam timing may be checked.

Intake opens 77° B. T. C.
 Intake closes 87° A. B. C.

Exhaust opens 92° B. B. C.
 Exhaust closes 74° A. T. C.

Timing to be checked at .005" tappet lift with no tappet clearance.

Caution: Because of valve lift (.400" lift on intake and exhaust), exhaust and intake valve to piston clearance must be checked. A minimum of .060" is required.

Install light push rods, part number 17904-59R.
 Ignition timing should be advanced to 48° B. T. C.
 Modify the carburetor. (1965 and earlier XL, XLCH only)

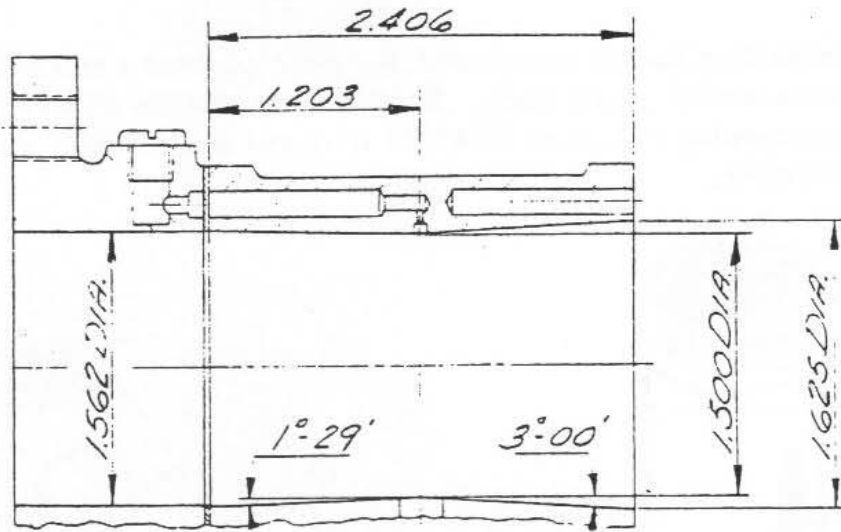

"XL CARBURETOR BODY"

Use throttle disc, part number 27280-51 (9x) in place of standard throttle disc. Install float valve and seat, part number 27382-58R. Space carburetor 1" (including gaskets). A spacer may be made for the float bowl to increase it's capacity. See illustration.

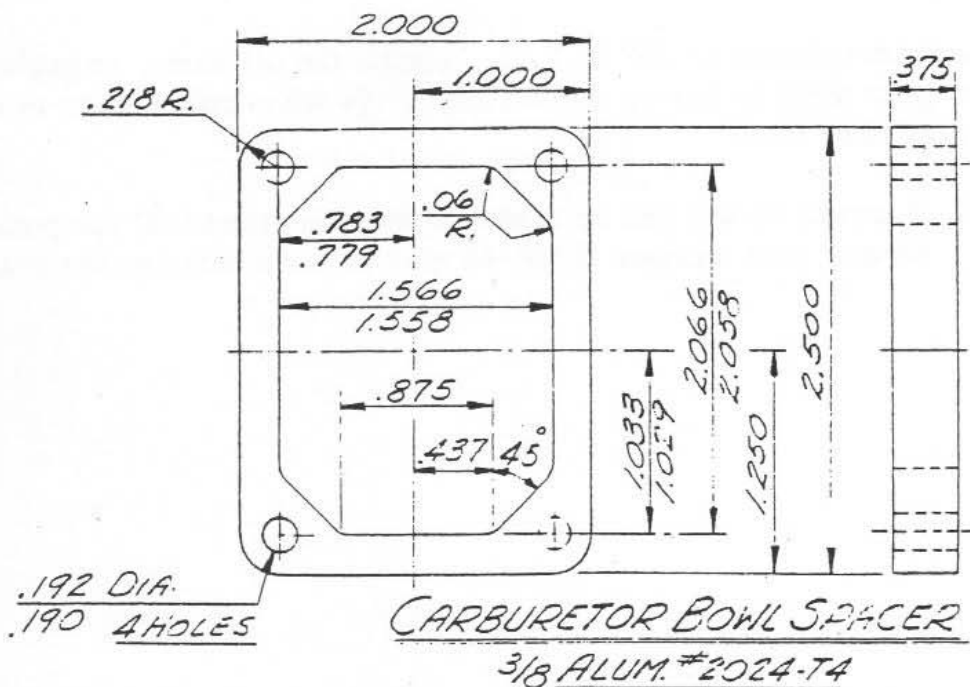

CARBURETOR BOWL SPACER
3/8 ALUM. #2024-T4

Straight exhaust pipes may be used.

Caution: When straight exhaust pipes and modified carburetor are used the # 4 high speed jet must be enlarged by drilling with a # 51 drill (.067").

A 1/4 - speed oil pump, part number 26203-54RA, and drive gear, part number 26318-54R, may be installed in place of the 1/2 - speed oil pump.

Caution: This oil pump will have lower oil pressure and should only be used for maximum performance (racing only).

Oil pump timing should be checked as follows:

Before installing the oil pump turn the gear counter clockwise until sleeve hole passes slot in pump body. Scribe mark across sleeve and body at slot when next opening in sleeve STARTS to open (use a .002" shim in opening). See illustration.

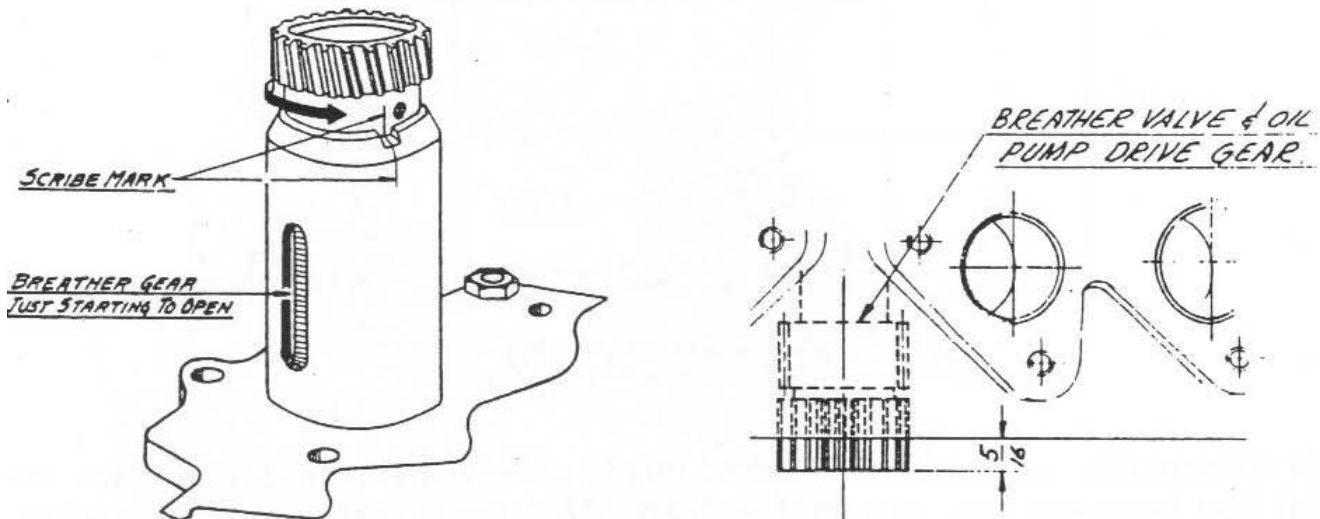

Set the front cylinder at 25° A. T. C. Install the oil pump, engaging the proper gear teeth to line up the scribe marks when pinion gear is set 5/16" from gear case face.

NOTE: If marks do not line up material may be ground off the pinion gear or shims, part number 18268-48 may be used between the gears.

Close ratio transmissions are available. Selection must be made to meet your requirements.

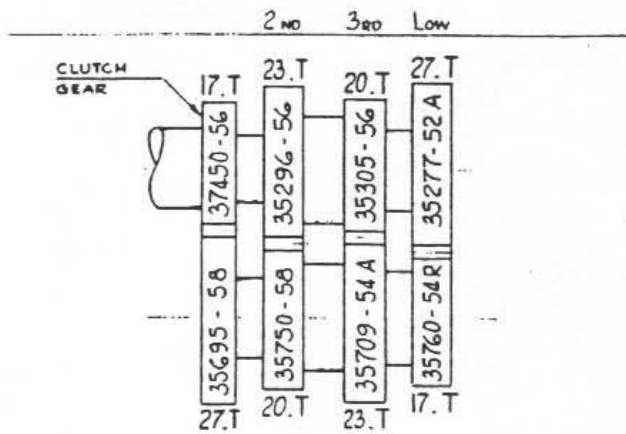

STANDARD "XLRTT" RATIO

SPEED	RATIO	GEARS
HIGH	1 TO 1	DIRECT
THIRD	1.38 TO 1	$\frac{27}{17} \times \frac{20}{23}$
SECOND	1.83 TO 1	$\frac{27}{17} \times \frac{23}{20}$
LOW	2.52 TO 1	$\frac{27}{17} \times \frac{27}{17}$

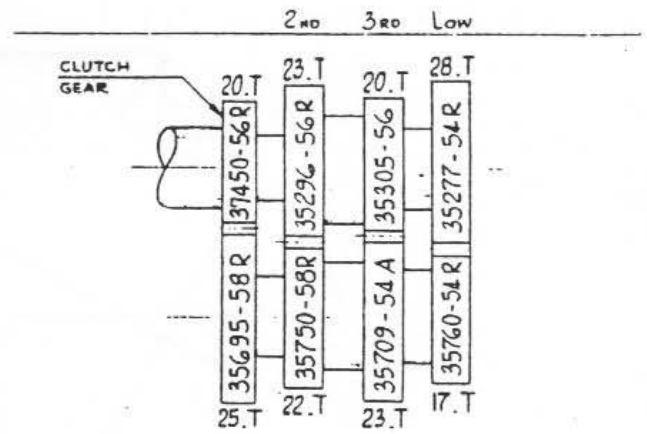

STANDARD "CLOSE" RATIO

SPEED	RATIO	GEARS
HIGH	1 TO 1	DIRECT
THIRD	1.09 TO 1	$\frac{25}{20} \times \frac{20}{23}$
SECOND	1.31 TO 1	$\frac{25}{20} \times \frac{23}{22}$
LOW	2.06 TO 1	$\frac{25}{20} \times \frac{28}{17}$

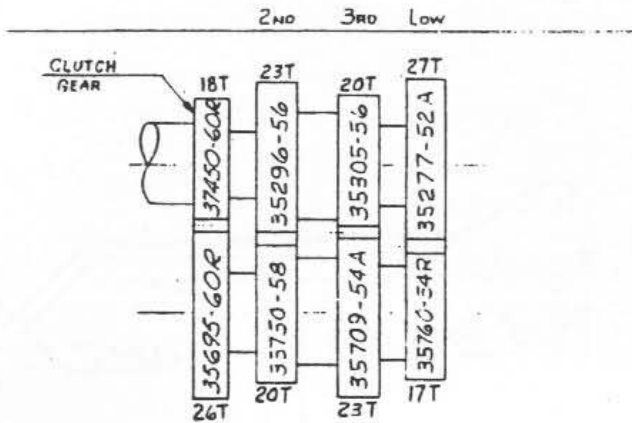

SPECIAL XLRTT RATIO "C"

SPEED	RATIO	GEARS
HIGH	1 TO 1	DIRECT
THIRD	1.26 TO 1	$\frac{18}{26} \times \frac{20}{23}$
SECOND	1.66 TO 1	$\frac{18}{26} \times \frac{23}{20}$
LOW	2.29 TO 1	$\frac{18}{26} \times \frac{27}{17}$

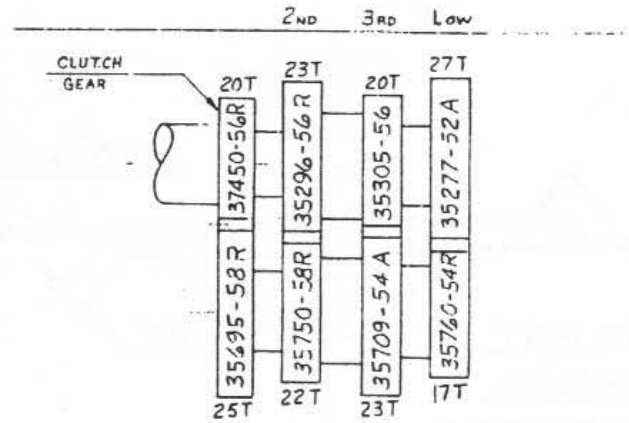

SPECIAL XLRTT RATIO "D"

SPEED	RATIO	GEARS
HIGH	1 TO 1	DIRECT
THIRD	1.09 TO 1	$\frac{25}{20} \times \frac{20}{23}$
SECOND	1.31 TO 1	$\frac{25}{20} \times \frac{23}{20}$
LOW	1.98 TO 1	$\frac{25}{20} \times \frac{27}{17}$

XLR MODIFICATIONS

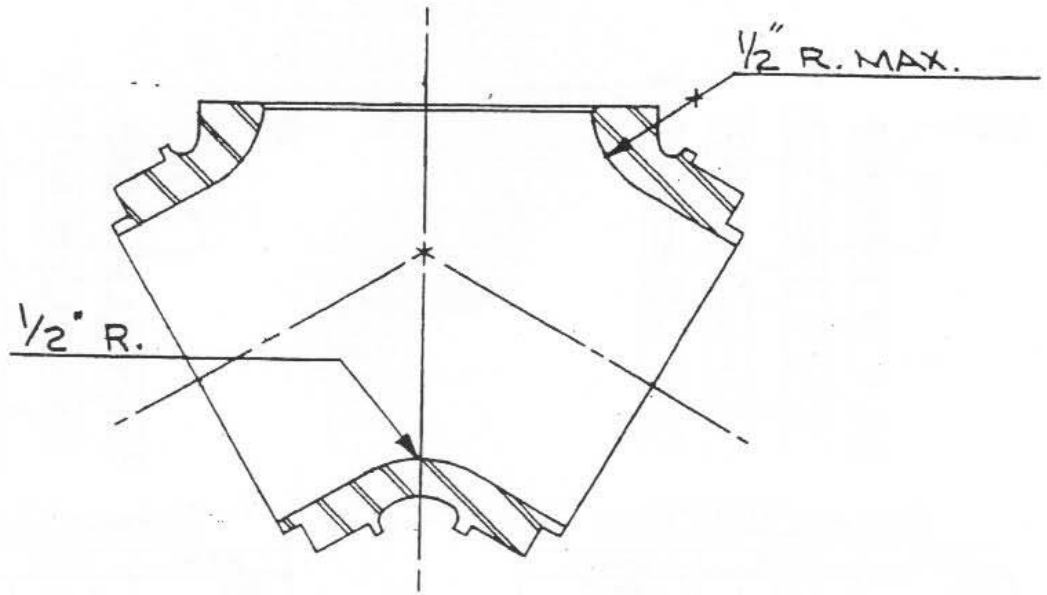

INTAKE MANIFOLD

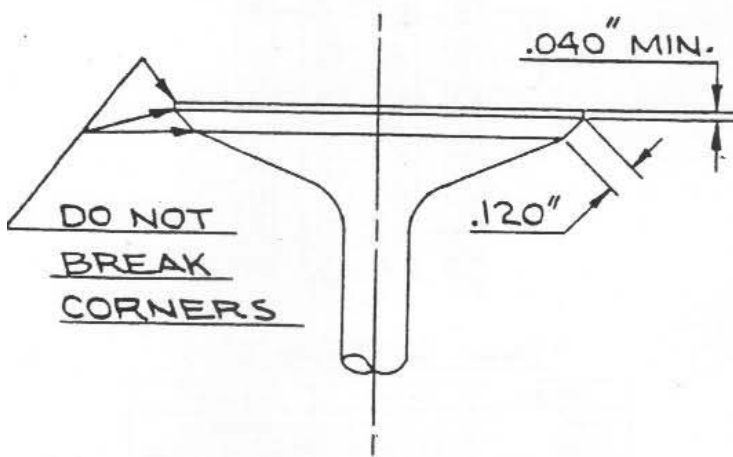

INTAKE VALVE

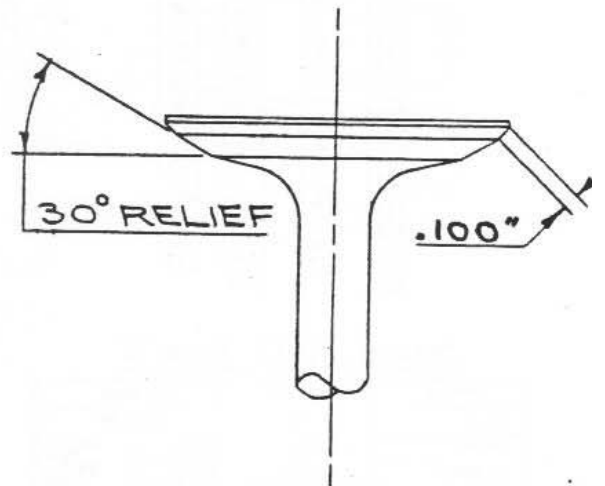

EXHAUST VALVE

'KR' TRANSMISSION GEAR RATIO

2ND 3RD Low

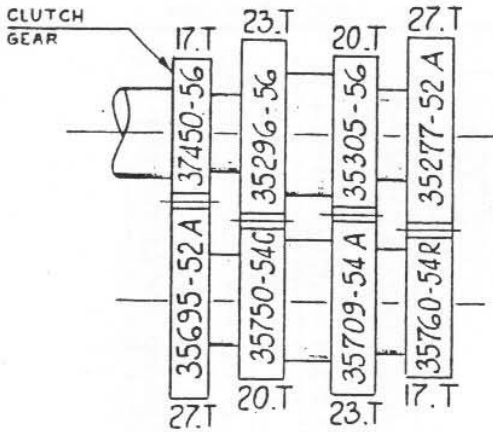

STANDARD 'KR' RATIO

SPEED	RATIO	GEARS
HIGH	1 TO 1	DIRECT
THIRD	1.38 TO 1	$\frac{27}{17} \times \frac{20}{23}$
SECOND	1.83 TO 1	$\frac{27}{17} \times \frac{23}{20}$
LOW	2.52 TO 1	$\frac{27}{17} \times \frac{27}{17}$

2ND 3RD Low

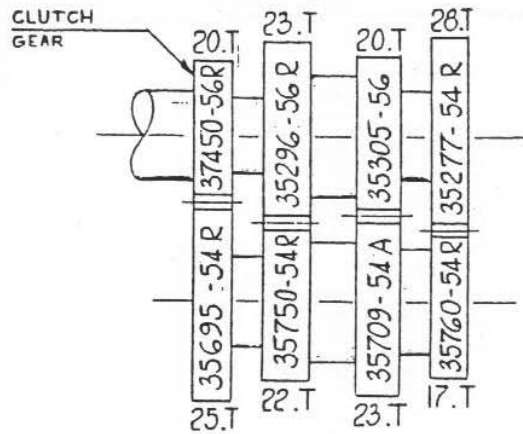

STANDARD 'CLOSE' RATIO

SPEED	RATIO	GEARS
HIGH	1 TO 1	DIRECT
THIRD	1.09 TO 1	$\frac{25}{20} \times \frac{20}{23}$
SECOND	1.31 TO 1	$\frac{25}{20} \times \frac{23}{22}$
LOW	2.06 TO 1	$\frac{25}{20} \times \frac{28}{17}$

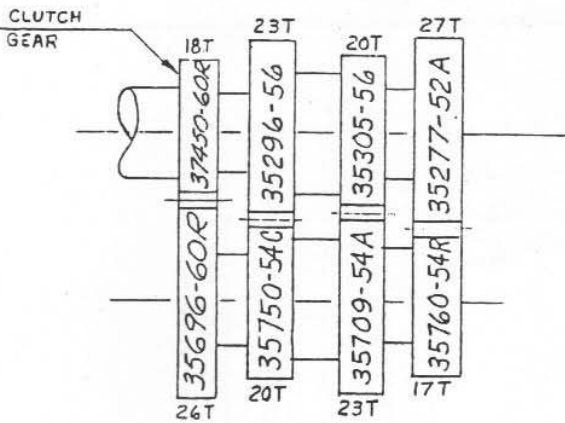

SPECIAL 'KR' RATIO 'C'

SPEED	RATIO	GEARS
HIGH	1 TO 1	DIRECT
THIRD	1.26 TO 1	$\frac{18}{26} \times \frac{20}{23}$
SECOND	1.66 TO 1	$\frac{18}{26} \times \frac{23}{20}$
LOW	2.29 TO 1	$\frac{18}{26} \times \frac{27}{17}$

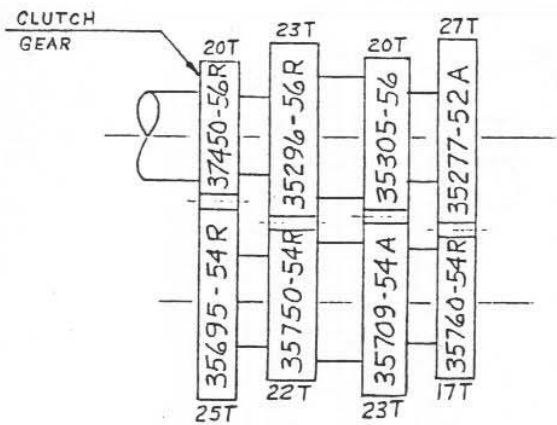

SPECIAL 'CLOSE' RATIO 'D'

SPEED	RATIO	GEARS
HIGH	1 TO 1	DIRECT
THIRD	1.09 TO 1	$\frac{25}{20} \times \frac{20}{23}$
SECOND	1.31 TO 1	$\frac{25}{20} \times \frac{23}{20}$
LOW	1.98 TO 1	$\frac{25}{20} \times \frac{27}{17}$

HARLEY - DAVIDSON MOTOR Co.

MILWAUKEE, WISCONSIN, U.S.A.

"KR" TRANSMISSION GEAR RATIO

2ND 3RD Low

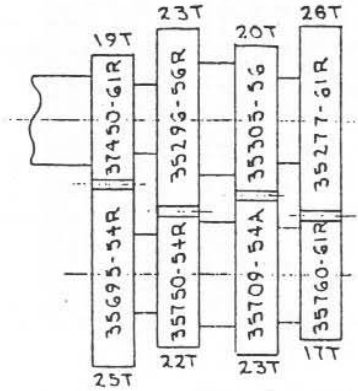

SPECIAL CLOSE RATIO "E"

SPEED	RATIO	GEARS
HIGH	1 TO 1	DIRECT
THIRD	1.14 TO 1	$25/19 \times 20/23$
SECOND	1.38 TO 1	$25/19 \times 23/22$
LOW	2.01 TO 1	$25/19 \times 26/17$

2ND 3RD Low

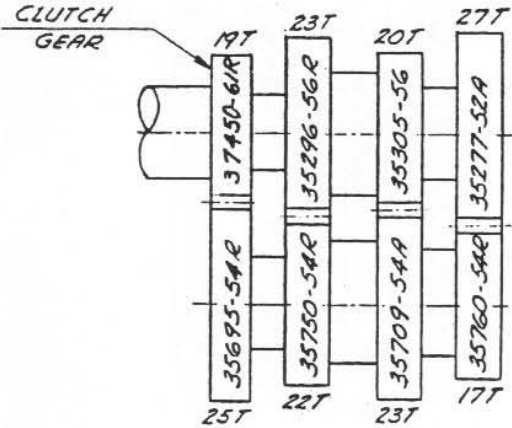

SPECIAL CLOSE RATIO "F"

SPEED	RATIO	GEARS
HIGH	1 TO 1	DIRECT
THIRD	1.14 TO 1	$25/19 \times 20/23$
SECOND	1.38 TO 1	$25/19 \times 23/22$
LOW	2.09 TO 1	$25/19 \times 27/17$

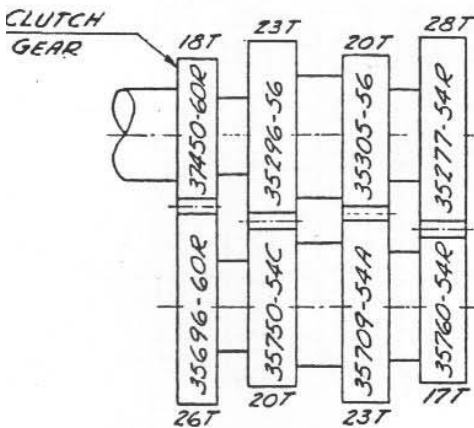

SPECIAL CLOSE RATIO "G"

SPEED	RATIO	GEARS
HIGH	1 TO 1	DIRECT
THIRD	1.26 TO 1	$26/18 \times 20/23$
SECOND	1.66 TO 1	$26/18 \times 23/20$
LOW	2.38 TO 1	$26/18 \times 28/17$

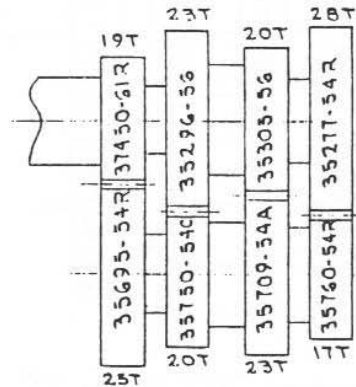

SPECIAL CLOSE RATIO "H"

SPEED	RATIO	GEARS
HIGH	1 TO 1	DIRECT
THIRD	1.14 TO 1	$25/19 \times 20/23$
SECOND	1.51 TO 1	$25/19 \times 23/20$
LOW	2.17 TO 1	$25/19 \times 28/17$

HARLEY - DAVIDSON MOTOR Co.
MILWAUKEE, WISCONSIN U.S.A.

"KR" TRANSMISSION GEAR RATIO

2ND 3RD LOW

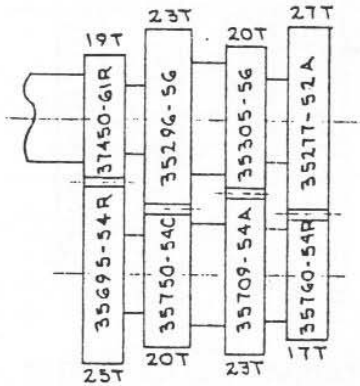

SPECIAL CLOSE RATIO "J"

SPEED	RATIO	GEARS
HIGH	1 TO 1	DIRECT
THIRD	1.14 TO 1	$\frac{25}{19} \times \frac{20}{23}$
SECOND	1.51 TO 1	$\frac{25}{19} \times \frac{23}{20}$
LOW	2.09 TO 1	$\frac{25}{19} \times \frac{27}{17}$

2ND 3RD LOW

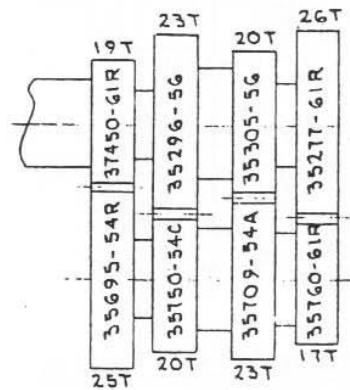

SPECIAL CLOSE RATIO "K"

SPEED	RATIO	GEARS
HIGH	1 TO 1	DIRECT
THIRD	1.14 TO 1	$\frac{25}{19} \text{ TO } \frac{20}{23}$
SECOND	1.51 TO 1	$\frac{25}{19} \text{ TO } \frac{23}{20}$
LOW	2.01 TO 1	$\frac{25}{19} \text{ TO } \frac{26}{17}$

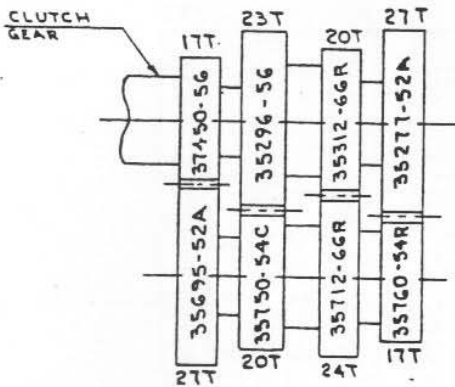

SPECIAL CLOSE RATIO "M"

SPEED	RATIO	GEARS
HIGH	1 TO 1	DIRECT
THIRD	1.32 TO 1	$\frac{27}{17} \times \frac{20}{24}$
SECOND	1.83 TO 1	$\frac{27}{17} \times \frac{23}{20}$
LOW	2.52 TO 1	$\frac{27}{17} \times \frac{27}{17}$

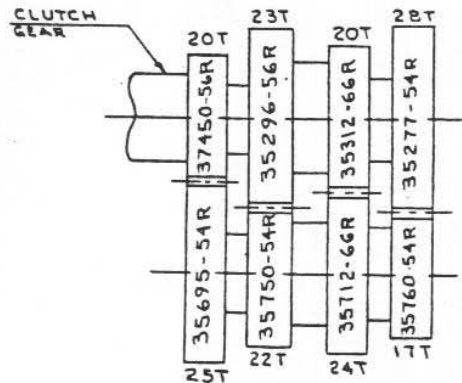

SPECIAL CLOSE RATIO "N"

SPEED	RATIO	GEARS
HIGH	1 TO 1	DIRECT
THIRD	1.04 TO 1	$\frac{25}{20} \times \frac{20}{24}$
SECOND	1.31 TO 1	$\frac{25}{20} \times \frac{23}{22}$
LOW	2.06 TO 1	$\frac{25}{20} \times \frac{28}{17}$

HARLEY - DAVIDSON MOTOR Co.
MILWAUKEE, WISCONSIN U. S. A.

"XLRTT" TRANSMISSION GEAR RATIO

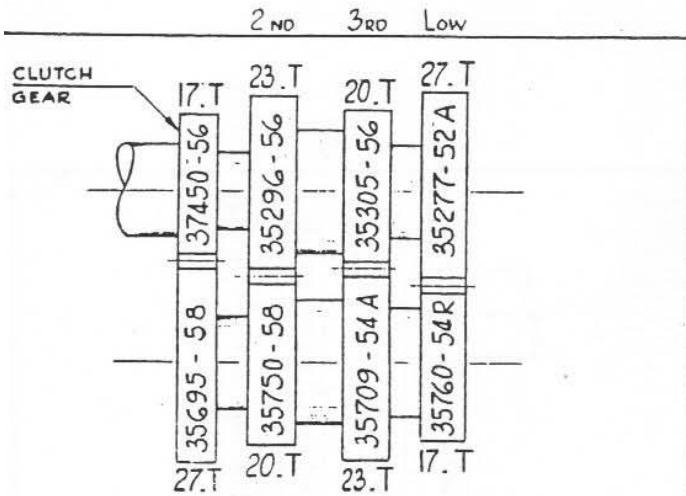

STANDARD "XLRTT" RATIO

SPEED	RATIO	GEARS
HIGH	1 TO 1	DIRECT
THIRD	1.38 TO 1	$\frac{27}{17} \times \frac{20}{23}$
SECOND	1.83 TO 1	$\frac{27}{17} \times \frac{23}{20}$
LOW	2.52 TO 1	$\frac{27}{17} \times \frac{27}{17}$

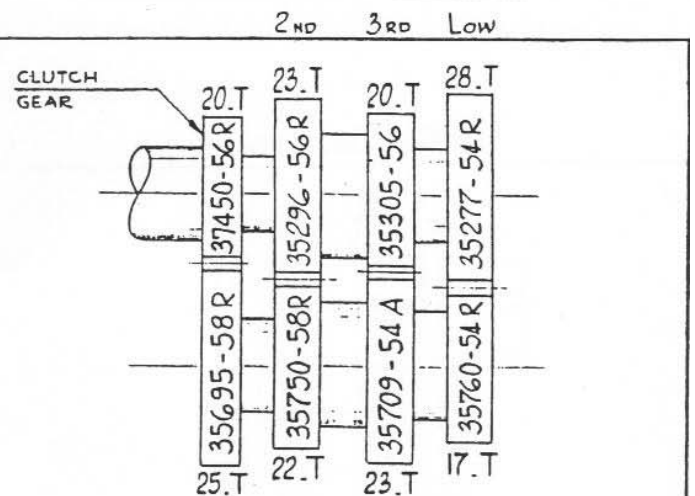

STANDARD "CLOSE" RATIO

SPEED	RATIO	GEARS
HIGH	1 TO 1	DIRECT
THIRD	1.09 TO 1	$\frac{25}{20} \times \frac{20}{28}$
SECOND	1.31 TO 1	$\frac{25}{20} \times \frac{23}{22}$
LOW	2.06 TO 1	$\frac{25}{20} \times \frac{28}{17}$

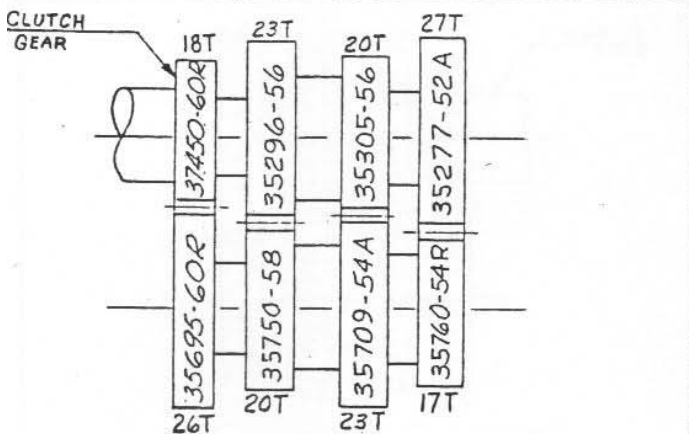

SPECIAL XLRTT RATIO "C"

SPEED	RATIO	GEARS
HIGH	1 TO 1	DIRECT
THIRD	1.26 TO 1	$\frac{18}{26} \times \frac{20}{23}$
SECOND	1.66 TO 1	$\frac{18}{26} \times \frac{23}{20}$
LOW	2.29 TO 1	$\frac{18}{26} \times \frac{27}{17}$

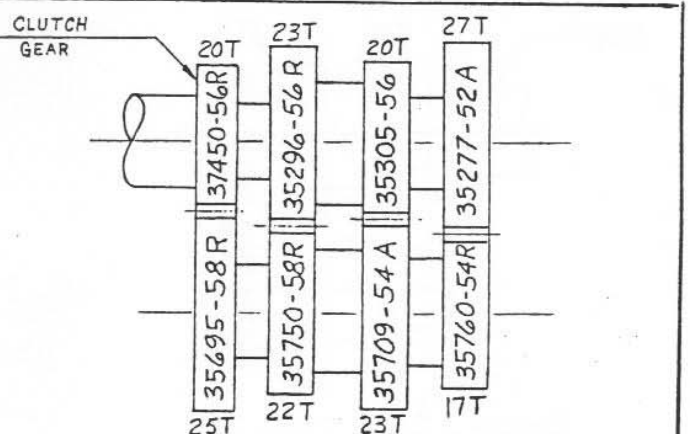

SPECIAL XLRTT RATIO "D"

SPEED	RATIO	GEARS
HIGH	1 TO 1	DIRECT
THIRD	1.09 TO 1	$\frac{25}{20} \times \frac{20}{23}$
SECOND	1.31 TO 1	$\frac{25}{20} \times \frac{23}{20}$
LOW	1.98 TO 1	$\frac{25}{20} \times \frac{27}{17}$

20T MOTOR SPROCKET
59T CLUTCH SPROCKET

REAR SPKT.	TRANSMISSION MAINSHAFT SPROCKET									
	15	16	17	18	19	20	21	22	23	24
36	7.08	6.64	6.25	5.90	5.59	5.31	5.06	4.83	4.62	4.42
37	7.28	6.82	6.42	6.06	5.74	5.46	5.20	4.96	4.75	4.55
38	7.47	7.01	6.59	6.23	5.90	5.60	5.34	5.09	4.87	4.67
39	7.67	7.19	6.77	6.39	6.06	5.75	5.48	5.23	5.00	4.79
40	7.87	7.38	6.94	6.56	6.21	5.90	5.62	5.36	5.13	4.92
41	8.06	7.56	7.11	6.72	6.37	6.05	5.76	5.50	5.26	5.04
42	8.26	7.74	7.29	6.88	6.52	6.20	5.90	5.63	5.39	5.16
43	8.46	7.93	7.46	7.05	6.68	6.34	6.04	5.77	5.52	5.29
44	8.65	8.11	7.64	7.21	6.83	6.49	6.18	5.90	5.64	5.41
45	8.85	8.30	7.81	7.38	6.99	6.64	6.32	6.03	5.77	5.53
46	9.05	8.48	7.98	7.54	7.14	6.79	6.46	6.17	5.90	5.65
49	9.63	9.03	8.50	8.03	7.60	7.22	6.88	6.57	6.28	6.02
50	9.83	9.22	8.68	8.19	7.76	7.38	7.02	6.71	6.41	6.14
51	10.03	9.40	8.85	8.36	7.92	7.52	7.16	6.84	6.54	6.27

30T MOTOR SPROCKET
59T CLUTCH SPROCKET

REAR SPKT.	TRANSMISSION MAINSHAFT SPROCKET												
	15	16	17	18	19	20	21	22	23	24			
36	4.72	4.42	4.16	3.93	3.73	3.54	3.37	3.22	3.08	2.95			
37	4.85	4.54	4.28	4.04	3.83	3.64	3.46	3.30	3.16	3.03			
38	4.98	4.67	4.39	4.15	3.93	3.74	3.56	3.40	3.25	3.11			
39	5.11	4.79	4.51	4.26	4.04	3.84	3.65	3.48	3.33	3.19			
40	5.24	4.92	4.63	4.37	4.14	3.93	3.75	3.58	3.42	3.28			
41	5.38	5.04	4.74	4.48	4.24	4.03	3.84	3.67	3.51	3.36			
42	5.51	5.16	4.86	4.59	4.35	4.13	3.93	3.75	3.59	3.44			
43	5.64	5.29	4.97	4.70	4.45	4.23	4.03	3.84	3.68	3.52			
44	5.77	5.41	5.09	4.81	4.55	4.33	4.12	3.93	3.76	3.60			
45	5.90	5.53	5.21	4.92	4.66	4.42	4.21	4.02	3.85	3.69			
46	6.03	5.65	5.32	5.03	4.76	4.52	4.31	4.11	3.93	3.77			
49	6.42	6.02	5.66	5.35	5.07	4.81	4.58	4.38	4.18	4.02			
50	6.56	6.15	5.78	5.46	5.17	4.92	4.68	4.47	4.28	4.10			
51	6.69	6.27	5.90	5.57	5.28	5.02	4.78	4.56	4.36	4.18			

25T MOTOR SPROCKET
59T CLUTCH SPROCKET

TRANSMISSION MAINSHAFT SPROCKET										
REAR SPKLT.	15	16	17	18	19	20	21	22	23	24
36	5.66	5.31	5.00	4.72	4.47	4.25	4.04	3.86	3.69	3.54
37	5.82	5.46	5.14	4.85	4.60	4.37	4.16	3.96	3.79	3.63
38	5.98	5.60	5.28	4.98	4.72	4.48	4.27	4.07	3.89	3.73
39	6.14	5.75	5.41	5.11	4.84	4.60	4.38	4.18	4.00	3.83
40	6.29	5.90	5.55	5.24	4.97	4.72	4.50	4.29	4.10	3.93
41	6.45	6.05	5.69	5.38	5.09	4.84	4.61	4.40	4.21	4.03
42	6.61	6.20	5.83	5.51	5.22	4.96	4.72	4.51	4.31	4.13
43	6.77	6.34	5.97	5.64	5.34	5.07	4.83	4.61	4.41	4.23
44	6.92	6.49	6.11	5.77	5.47	5.19	4.94	4.72	4.51	4.33
45	7.08	6.64	6.25	5.90	5.59	5.31	5.06	4.83	4.62	4.43
46	7.24	6.79	6.39	6.03	5.71	5.43	5.17	4.93	4.72	4.52
49	7.70	7.22	6.80	6.42	6.08	5.78	5.50	5.25	5.02	4.82
50	7.87	7.38	6.94	6.56	6.21	5.90	5.62	5.36	5.14	4.92
51	8.02	7.52	7.08	6.69	6.33	6.02	5.73	5.47	5.23	5.02

34T MOTOR SPROCKET
59T CLUTCH SPROCKET

		TRANSMISSION MAINSHAFT SPROCKET											
REAR SPKT.	15	16	17	18	19	20	21	22	23	24			
49	5.67	5.31	5.00	4.72	4.48	4.25	4.05	3.86	3.70	3.54			
50	5.78	5.42	5.10	4.82	4.57	4.34	4.13	3.94	3.77	3.61			
51	5.90	5.53	5.21	4.92	4.66	4.43	4.21	4.02	3.85	3.69			

INSTALLATION OF BALL BEARING TO REAR
INTAKE CAM

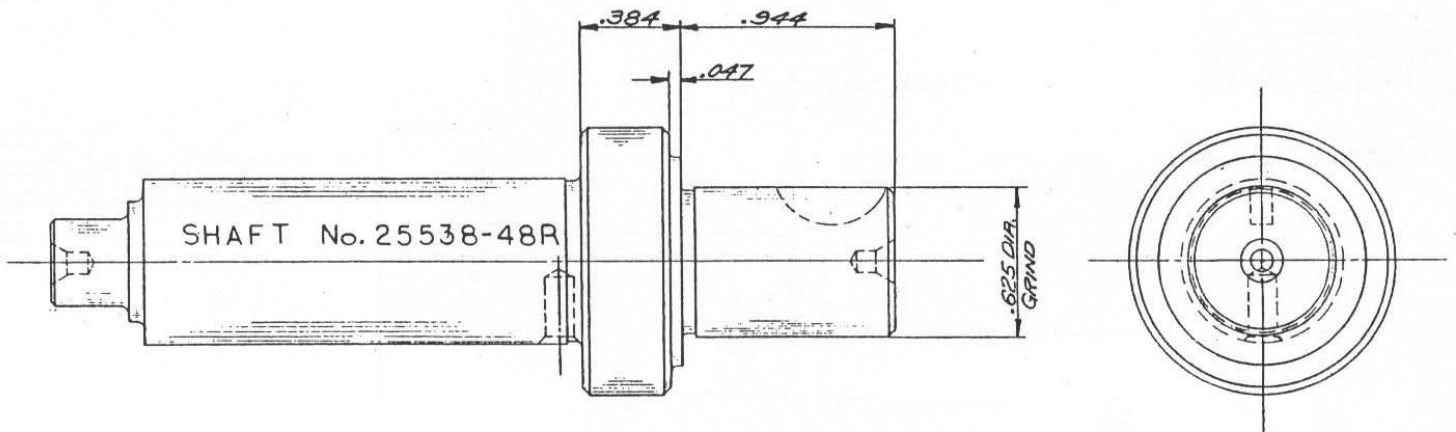

USE "NEW DEPARTURE" BEARING No. R-10 OR EQUIV.
REMOVE BUSHING FROM CAM COVER

HARLEY-DAVIDSON MOTOR Co.

INTAKE DRIVE SHAFT

CRANKCASE ASSY - RIGHT
DET # 4023-288 RC (SEE SECTION 'CC')

BALL BEARING # 9030 B

TRANS. MAINSHAFT.
DET NO 2180-108 RC

NOTE:
MACHINING RIGHT CRANKCASE
FOR BALL BEG. TRANSMISSION
MAINSHAFT

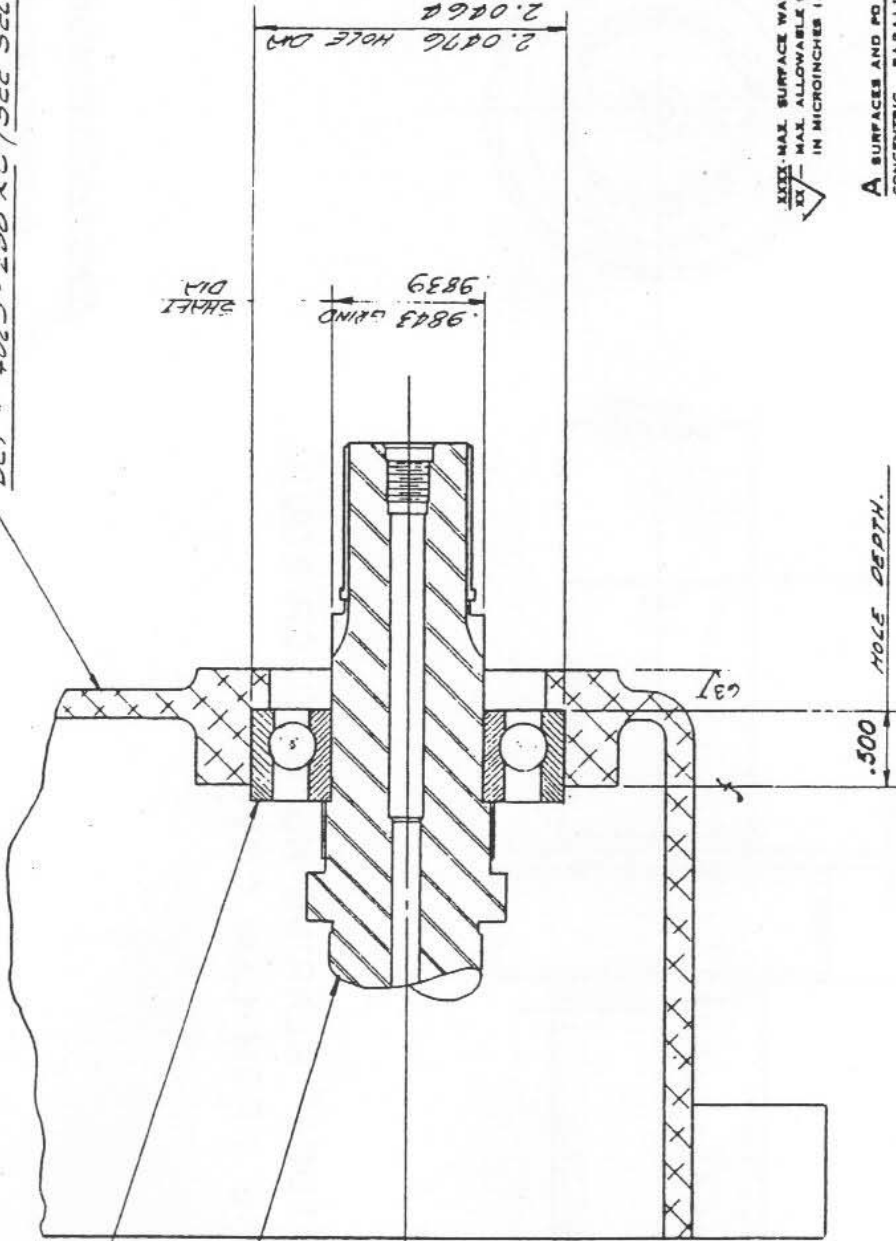

XXX - MAX SURFACE WAVINESS IN INCHES
MAX ALLOWABLE SURFACE ROUGHNESS
XX - IN MICROINCHES (AVG. R. M. S. VALUE)

A SURFACES AND PD OF () MUST BE
CONCENTRIC. PARALLEL. FLAT. SQUARE
AND TRUE (AS APPLICABLE) TO EACH OTHER
WITHIN FULL INDICATOR READING
UNLESS OTHERWISE SPECIFIED.

UNLESS OTHERWISE SPECIFIED
THE FOLLOWING TOLERANCES
APPLY:
XX - TOLERANCE OF $\pm .010$
XXX - TOLERANCE OF $\pm .005$
XXXX - TOLERANCE OF $\pm .0005$
ANGULAR ± 15 MINUTES
DRILLED HOLES $\pm .010$
FORGINGS, CASTINGS AND
COMMERCIAL STOCK SIZE TOL-
ERANCES ARE NOT INCLUDED
IN THE ABOVE, WHERE NEC.
NECESSARY REMOVE BURRS AND
SHARP CORNERS. NOT TO EX-
CEED .015 $\pm 45^\circ$ CHAMFER.
REPORT ALL ERRORS

HARLEY-DAVIDSON MOTOR CO.
MILWAUKEE, WISCONSIN, U. S. A.

CRANKCASE ASSY

TRACED BY: *7/13* SCALE: *FULL* DATE: *10/21/53*

CHECKED BY: _____ DETAIL NO. _____

DRG. NO. _____

ENG. ORD. NO.	MODEL	LET.	DATE
MATERIAL			
HEAT TREATMENT			
FINISH	PATTERN NO.	ALTERATIONS	

1 2 3 4 5 6

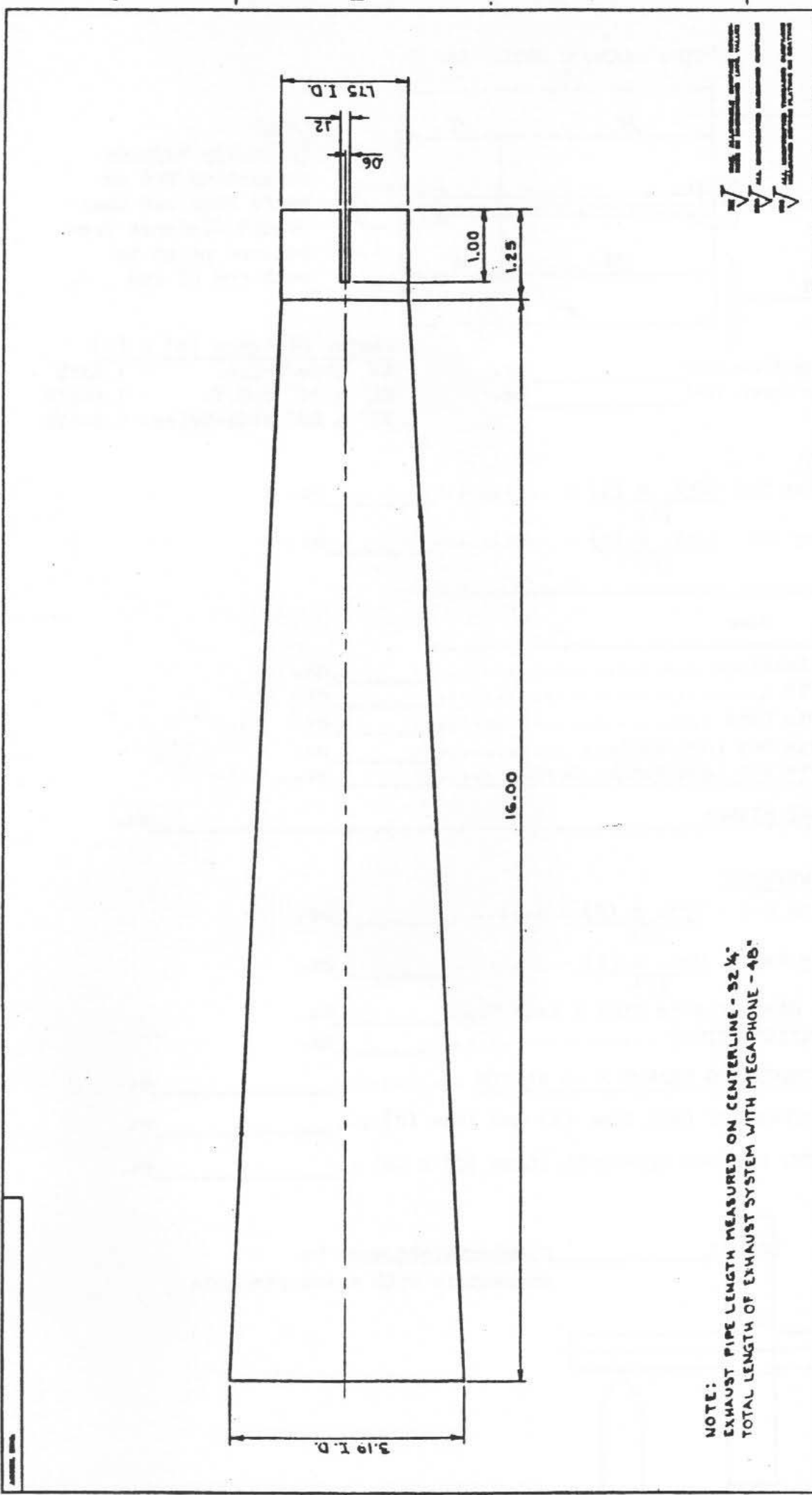

NOTE:
 EXHAUST PIPE LENGTH MEASURED ON CENTERLINE - 32 1/4"
 TOTAL LENGTH OF EXHAUST SYSTEM WITH MEGAPHONE - 48"

ALL DIMENSIONS UNLESS OTHERWISE SPECIFIED ARE IN INCHES
 ALL DIMENSIONS UNLESS OTHERWISE SPECIFIED ARE IN MILLIMETERS
 ALL DIMENSIONS UNLESS OTHERWISE SPECIFIED ARE IN MILLIMETERS

HARLEY-DAVIDSON MOTOR CO. MILWAUKEE, WISCONSIN U.S.A.		MEGAPHONE	
UNLESS OTHERWISE SPECIFIED THE FOLLOWING TOLERANCES APPLY: SIZE - TOLERANCE OF ± 0.015 HOLE - TOLERANCE OF ± 0.010 ANGULAR TOL. ± 10 MIN.		REV. DENZER DATE 11-15-68 SCALE 1-1 DATE DATE DATE 2078-51	
FORMER, EASTING AND IN THE ABOVE, WHICH INC. HARLEY-DAVIDSON MOTOR CO. DOES NOT SCALE DRAWING REPORT ALL ERRORS		DATE DATE DATE DATE DATE DATE	
MATERIAL .0359 SHEET STEEL G.E.S. 32126		DATE DATE DATE DATE DATE DATE	

ENGINE BALANCE DATA - NO. 2.

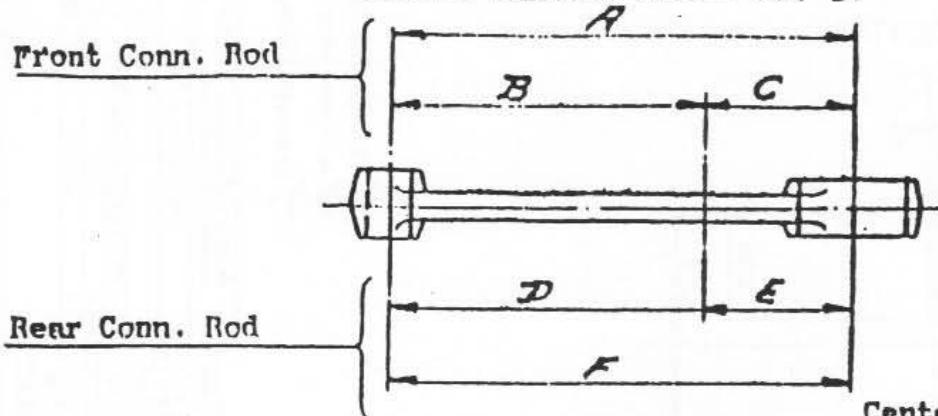

NOTE:
Carefully balance connecting rod on knife edge and then record distance from balance point to each end of rod

Weight of Front Conn. Rod _____ oz.
Weight of Rear Conn. Rod _____ oz.

Center Distance (A) & (F)
(45" Side-Valve - 7.4375
(61" & 74" O.H.V. - 7.46875
(74" & 80" Side-Valve - 7.90625

ROTARY WEIGHTS:

Front Connecting Rod $\frac{Wgt. \times (D)}{(A)}$ - oz.
Rear Connecting Rod $\frac{Wgt. \times (D)}{(F)}$ - oz.

No. to Weigh	Name	oz.
1-set	Roller Bearings	oz.
1	Crank Pin	oz.
2	Crank Pin Nuts	oz.
2	Crank Pin Nut Lock Washers	oz.
2	Crank Pin Nut Lock Washer Screws	oz.

(A) TOTAL ROTARY WEIGHT _____ oz.

RECIPROCATING WEIGHTS:

Front Connecting Rod - $\frac{Wgt. \times (C)}{(A)}$ - oz.
Rear Connecting Rod - $\frac{Wgt. \times (E)}{(F)}$ - oz.
2-Pistons with Rings, Piston Pins & Lock Rings _____ oz.
TOTAL RECIPROCATING WEIGHT oz.

(B) TOTAL RECIPROCATING WEIGHT x .5 FACTOR oz.

(C) TOTAL COUNTERWEIGHT (Add line (A) and line (B)) ... oz.

COUNTERWEIGHT FOR ONE FLY-WHEEL (Line (C) x .5) .. oz.

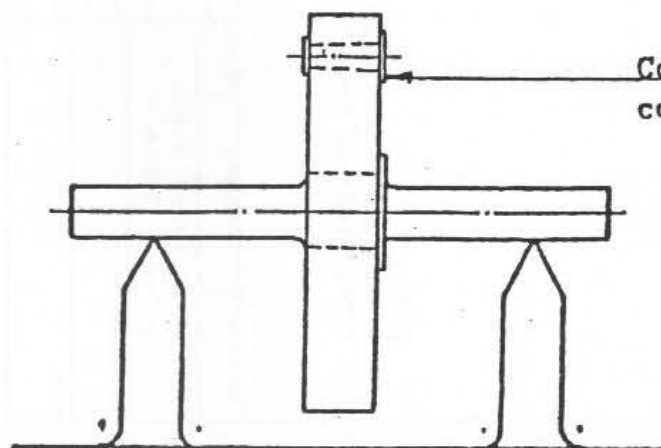

Counterweight must be concentric with crank pin hole.

FORMULAS

FOR FINDING GEAR RATIO, MOTOR SPEED IN R.P.M.,
& SPEED OF MOTORCYCLE IN M.P.H.

IF ANY TWO OF THE FOLLOWING: GEAR RATIO-MOTOR SPEED OR MOTORCYCLE SPEED, ARE KNOWN; THE THIRD CAN BE CALCULATED FROM THE FOLLOWING BASIC FORMULA

$$\frac{M.P.H. \times G.R.}{K} = R.P.M.$$

WHERE

$$K = \frac{60}{\text{REV. OF TIRE PER MILE}}$$

FOR: 3.25x19 TIRE $K = .077$
4.00x18 TIRE $K = .078$

M.P.H. = MOTORCYCLE SPEED

G.R. = GEAR RATIO

R.P.M. = MOTOR SPEED

THEREFORE

$$\underline{\underline{G.R.}} = \frac{K \times R.P.M.}{M.P.H.}$$

$$\underline{\underline{R.P.M.}} = \frac{M.P.H. \times G.R.}{K}$$

$$\underline{\underline{M.P.H.}} = \frac{R.P.M. \times K}{G.R.}$$

NOTE:

FOR ASSEMBLY OF FACE PLATE
TO HUB USE SCREW #1300 (H-D)

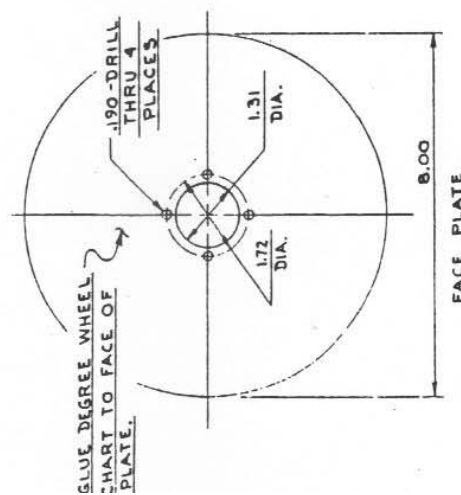

FACE PLATE
.125 THICK ALUM.
OR STEEL SHEET STOCK

#12-24 N.C. THD.
4 PLACES

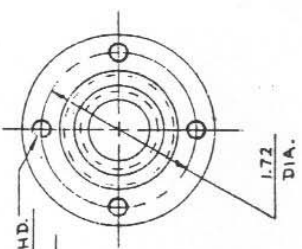

FACE PLATE HUB
2.125 DIA. STEEL
STOCK

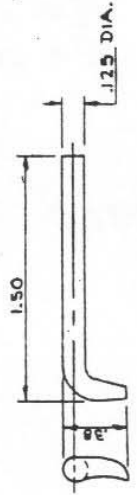
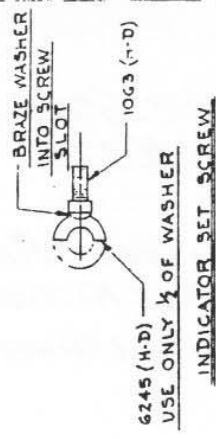
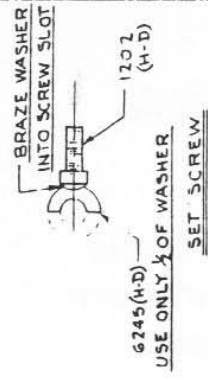
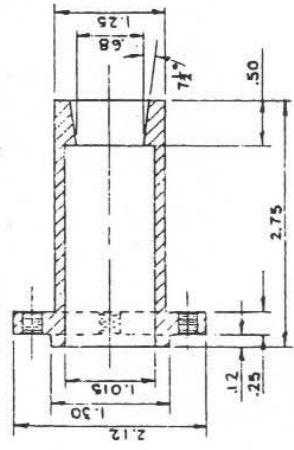

POINTER
.125 DIA. STEEL ROD

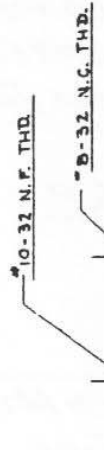

#8-32 N.C. THD.

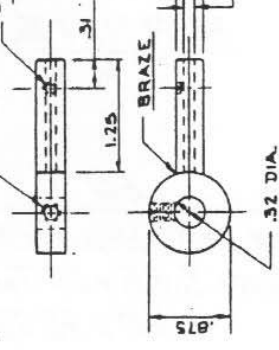

MAY BE DRILLED
BEFORE OR AFTER
BRAZING.

POINTER ADAPTER
STEEL ROD

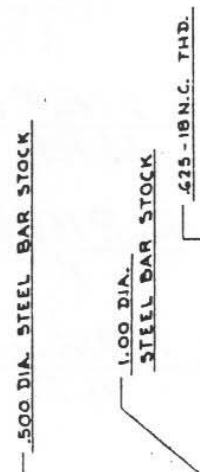

BRAZE OR
MAKE A
PRESS FIT

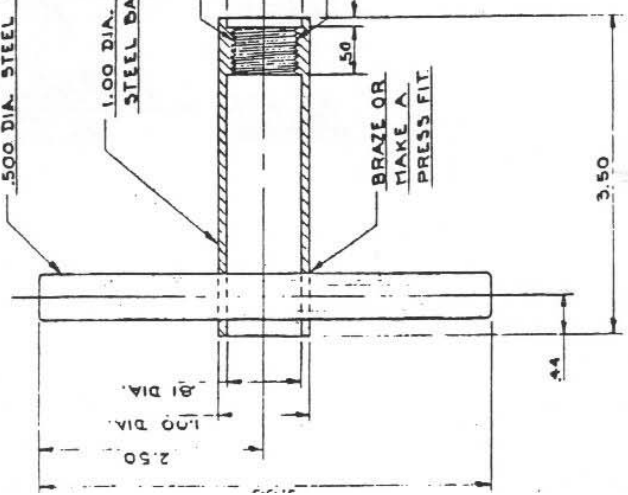

250-28 N.F. THD.

POINTER STUD

4106 (H-D)

CUT OFF
EXCESS BOLT

HARLEY-DAVIDSON MOTOR CO. MILWAUKEE, WISCONSIN U. S. A.	
DEGREE WHEEL	
"XR" - "XRTT" - "XLRTT"	
DESIGNED BY C. O. D.	DATE 3-20-61

INTAKE OPENS B.T.C.
INTAKE CLOSES A.B.C.
EXHAUST OPENS B.B.C.
EXHAUST CLOSES A.T.C.

www.ClassicCycles.org

